



California Faucets®

**Descanso™**

**1/2" PRESSURE BALANCE TRIM ONLY**

**Features**

- Screwless faceplate
- 7-1/4" round faceplate
- Less head, arm, flange and spout
- Over 30 finishes including 15 PVD finishes

**Codes/Standards**

Product meets or exceeds the following:

- ASME A112.18.1/CSA B125.1
- ASSE 1016
- ADA compliant

**TO-PBL-30K  
TO-PBL-30F**



(TO-PBL-30K SHOWN)

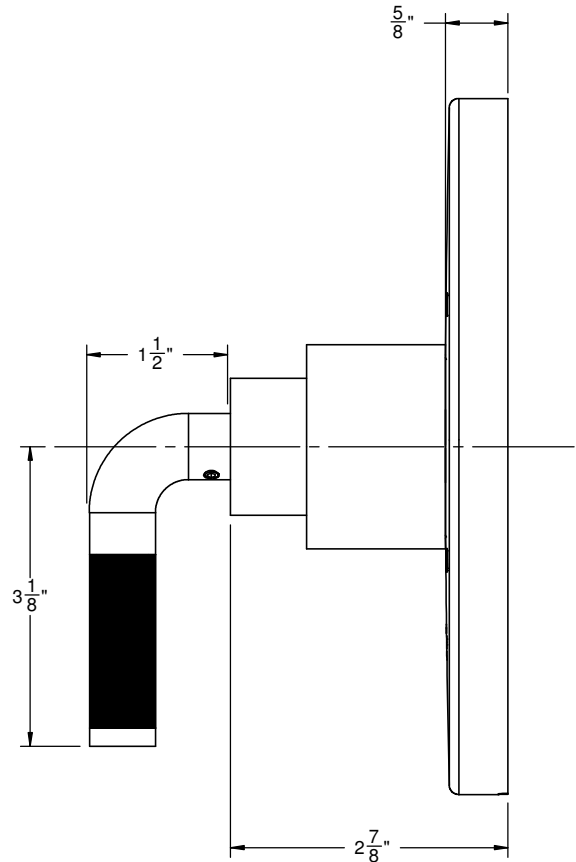
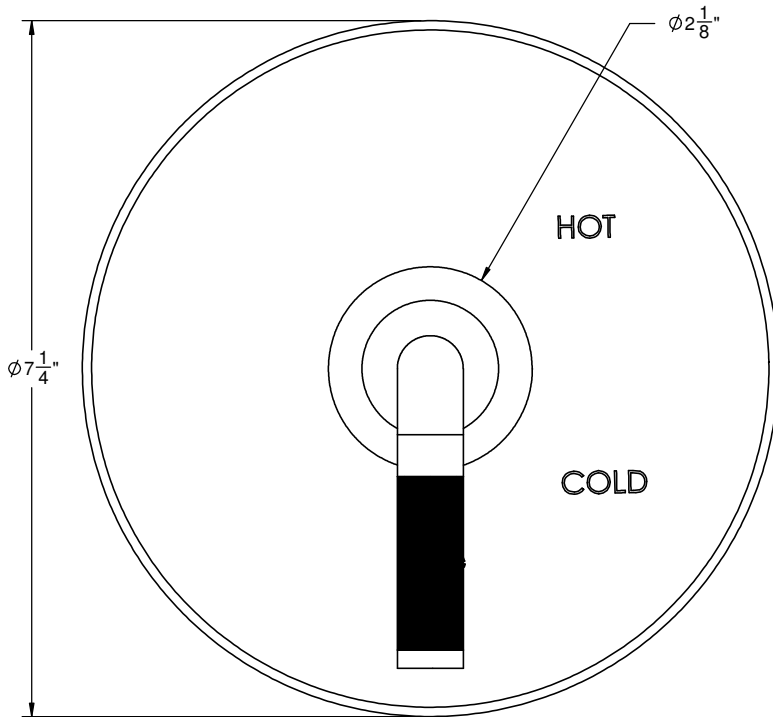

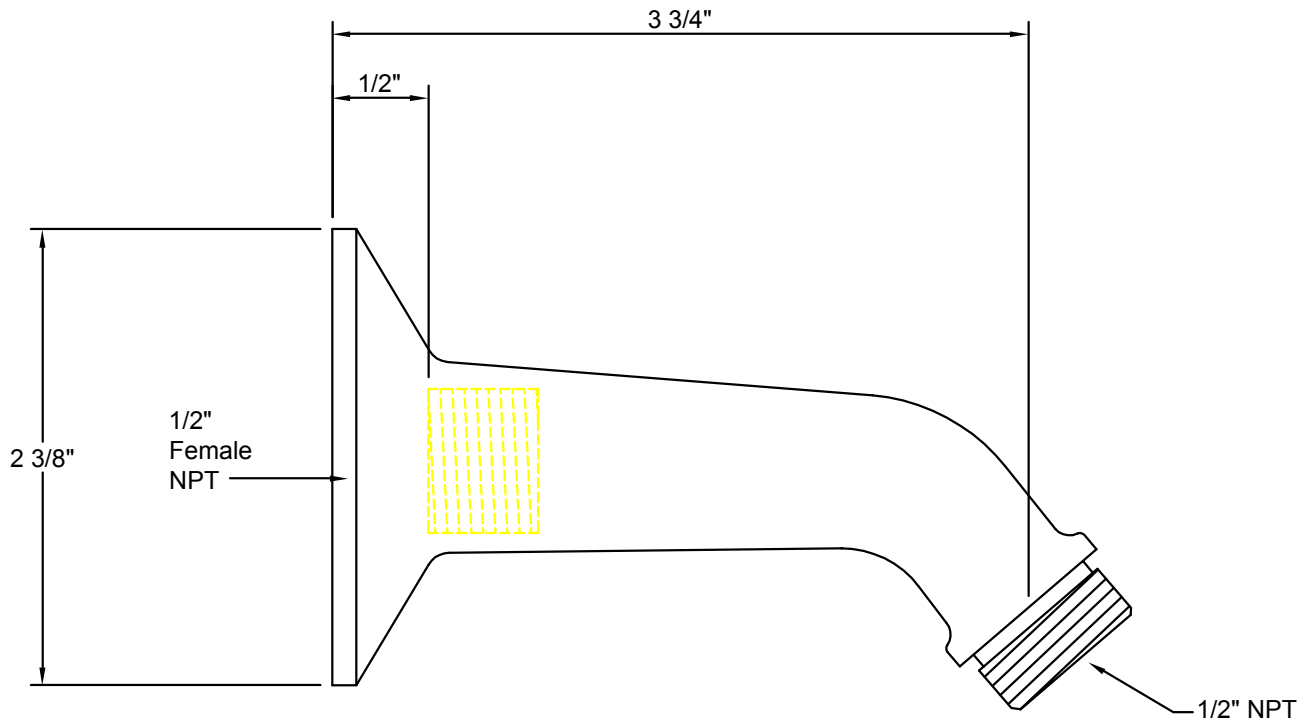

A Division of  
California Faucets

Decorative Trim for Bath & Kitchen  
info@calfaucets.com  
www.calfaucets.com

5231 Argosy Drive  
Huntington Beach, CA 92649

Tel: 714-891-7797  
Fax: 714-891-2478  
Toll Free: 800-822-8855

Fixture:

**SH-01**

Revision date: April 1, 2005

Date: October 1, 2004

Scale: None

Drawn by: William Linares  
william@calfaucets.com

Technical Supervisor: Joe Mainberger



9206

### Features

- Available in over 30 finishes including 11 PVD finishes
- All brass construction
- 6" spout reach
- 1/2" NPT inlet

### Codes/Standards Applicable

Specified model meets or exceeds the following:

- ASME A112.18.1/CSA B125.1

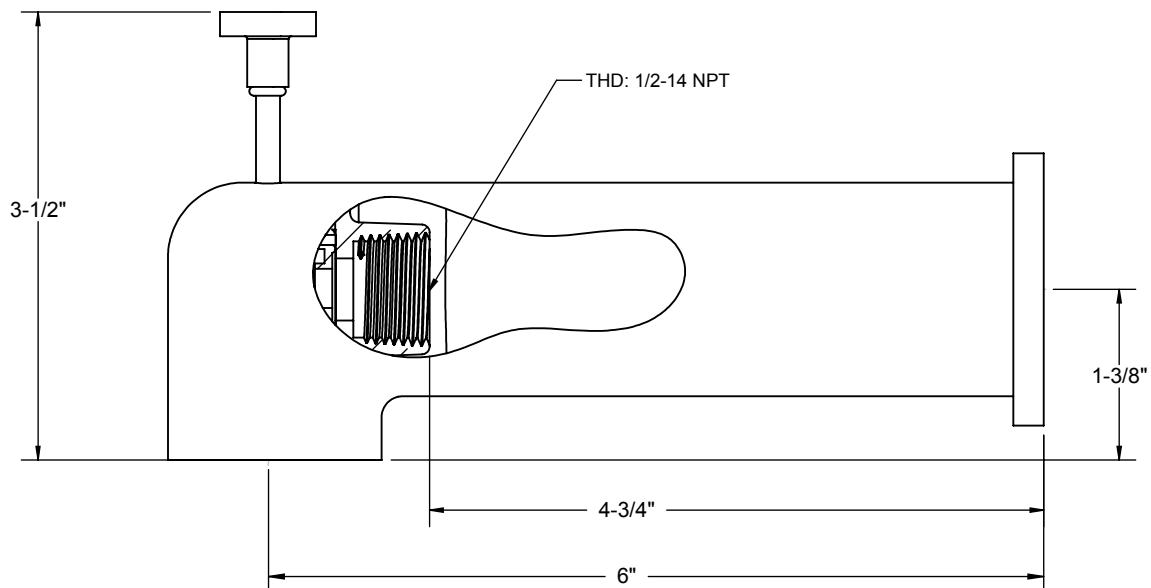
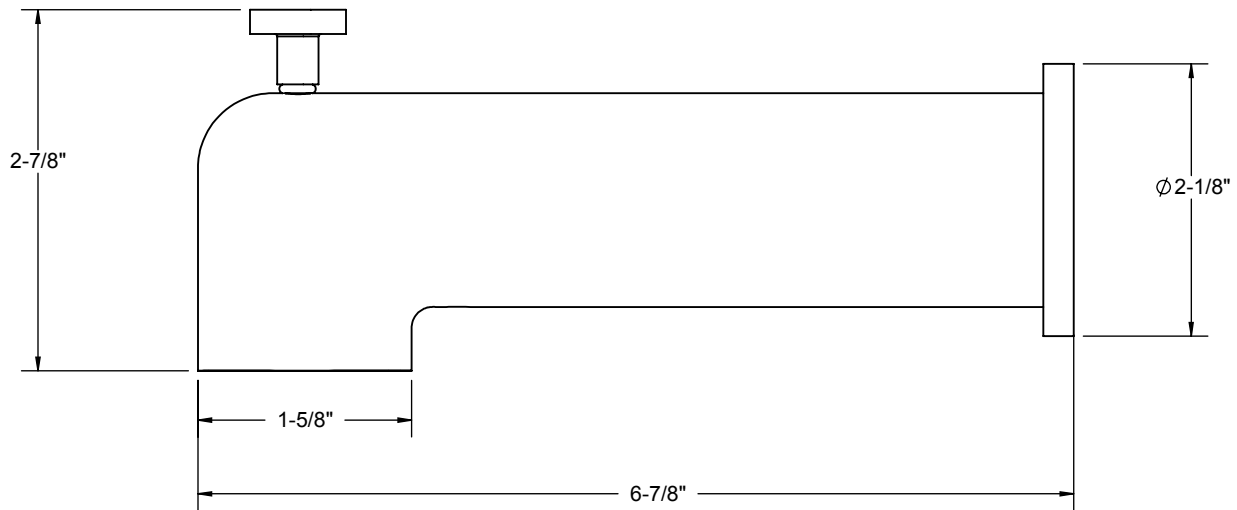
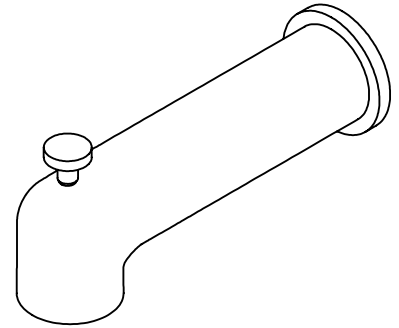

DIMENSIONS SHOWN TO NEAREST 1/16"



California Faucets®

# Showerhead

3-5/16" 6 JETS

## Features

- 1/2" FIP inlet
- Brass construction
- 3-5/16" diameter
- Replace .FR with desired max flow rate:  
 SH-04T.25 for 2.5 gpm  
 SH-04T.20 for 2.0 gpm  
 SH-04T.18 for 1.8 gpm  
 SH-04T.15 for 1.5 gpm

SH-04T.25  
 SH-04T.20  
 SH-04T.18  
 SH-04T.15

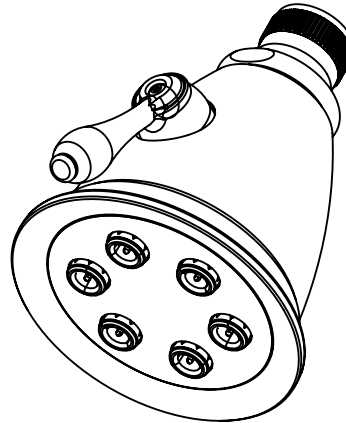

## Codes/Standards

Product meets or exceeds the following:

- ASME A112.18.1/CSA B125.1
- CEC (1.8 & 1.5 gpm)
- DOE (2.5, 2.0, 1.8, & 1.5 gpm)
- Commonwealth of MA

