



Features

- Only available in natural stainless steel
- Veneer trim over plate for sharp finished edge look
- Stainless steel recess trim cover & drain rough with 2" dual Stainless steel outlet
- Removable recess trim cover with no visible screws
- Height adjustable leveling pads position tile in recess trim cover flush with tile surface
- Height adjustable support legs on drain rough to accomodate uneven sub-floor
- Drain rough design prevents standing water
- Dual outlet total flow rate 36 gpm (136 Lpm) with 1/4" head of water
- Removable debris strainers
- Compatible with following waterproofing systems:
 - Liquid membrane with direct No-Hub connection
 - Hot mop or PVC/CPE when used with 9189-, 9189-ABS or 9189-PVC (sold seperately)
- Sanded flange to secure liquid membrane waterproofing
- Tile trim template, tile straight edge framing holders and mudguard included

9181-D2S-XX

(9186-DXX & 9188-D2P-XX)

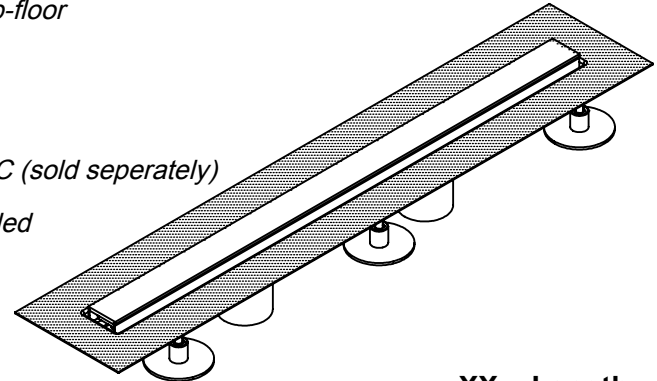

XX = Length
(52", 56", 60", 63", 67", 71", 75", 79")

Codes/Standards Applicable

Specified model meets or exceeds the following:

- ASME A112.18.2-2005/CSA B125.2-05 & IAPMO IGC 195-2010

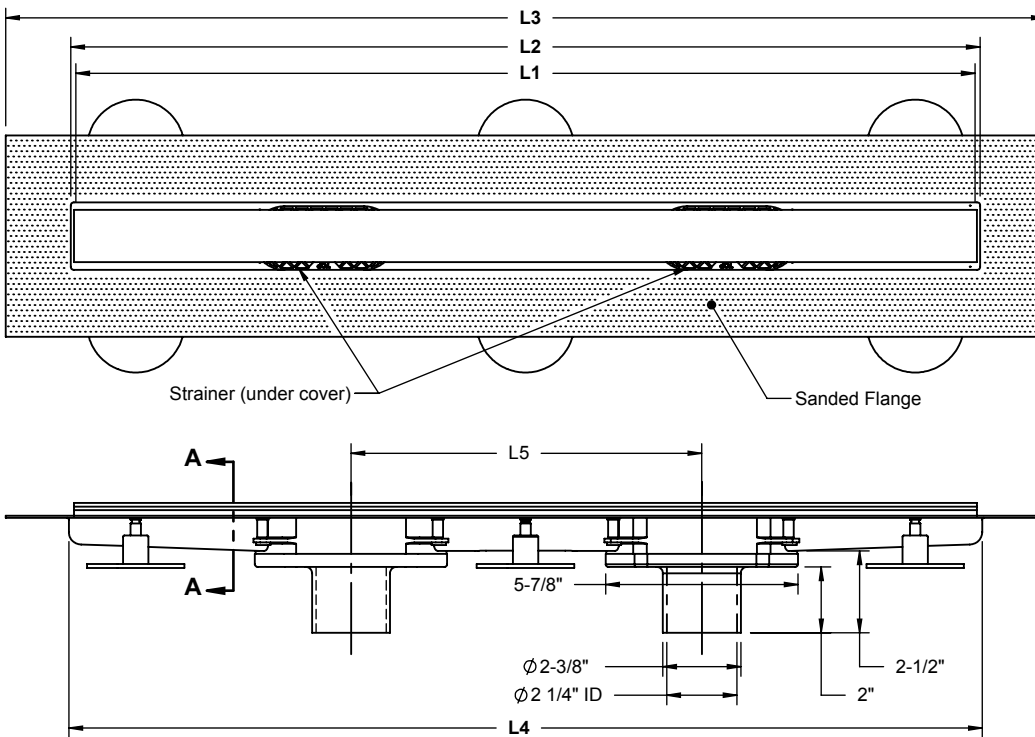

MODEL	L1	L2	L3	L4	L5	MIN INSTALL LENGTH
9181-D2S-52	51	51 ³ / ₁₆	55 ¹ / ₈	51 ¹ / ₁₆	19 ¹¹ / ₁₆	56
9181-D2S-56	55	55 ¹ / ₈	59 ¹ / ₁₆	55 ¹ / ₄	19 ¹¹ / ₁₆	60
9181-D2S-60	58 ¹⁵ / ₁₆	59 ¹ / ₁₆	63	59 ³ / ₁₆	23 ⁵ / ₈	63
9181-D2S-63	62 ⁷ / ₈	63	66 ¹⁵ / ₁₆	63 ¹ / ₈	23 ⁵ / ₈	67
9181-D2S-67	66 ³ / ₄	66 ¹⁵ / ₁₆	70 ⁷ / ₈	67 ¹ / ₁₆	27 ⁹ / ₁₆	71
9181-D2S-71	70 ³ / ₄	70 ⁷ / ₈	74 ¹³ / ₁₆	71	27 ⁹ / ₁₆	75
9181-D2S-75	74 ⁵ / ₈	74 ¹³ / ₁₆	78 ³ / ₄	75	31 ¹ / ₂	79
9181-D2S-79	78 ⁹ / ₁₆	78 ³ / ₄	82 ¹¹ / ₁₆	78 ⁷ / ₈	31 ¹ / ₂	83

Section A-A
Scale 2:1

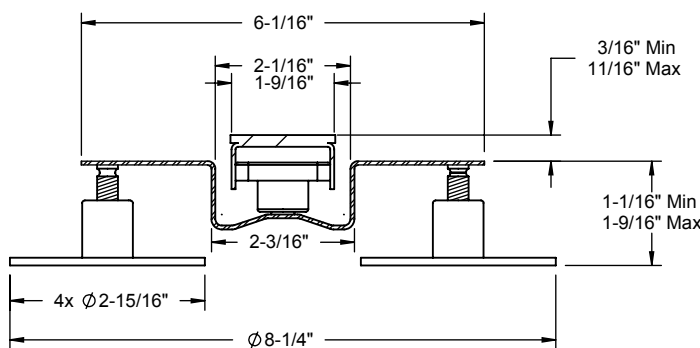

All Dimensions Shown To Nearest 1/16"

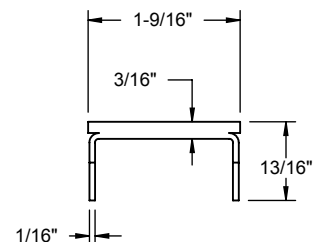

Trim Cover Profile