

**Features**

- 25+ artisan finishes including 12 PVD finishes
- All brass construction
- No additional wall or trap stabilizer kit required
- Tub filler maximum flow rate: 13 gpm (49.2 L/min) at 60 psi
- Handshower flow rate: 2.0 gpm (7.6 L/min), 1.8 gpm (6.8 L/min)
- 1/4 turn ceramic disc cartridges
- Rough kit (9516) sold separately

**Codes/Standards Applicable**

Product meets or exceeds the following:

- ASME A112.18.1/CSA B125.1
- CEC (1.8 gpm) & DOE (1.8 & 2.0 gpm)
- Commonwealth of MA
- EPA WaterSense handshower (2.0 gpm)
- ADA compliant (with lever handles)
- Installation of upstream tempering device may be required (verify local codes)

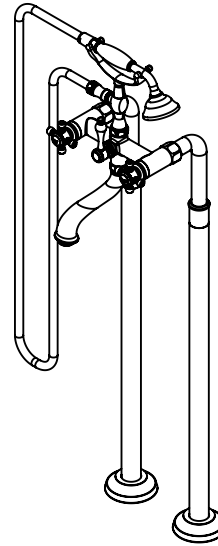

1503-XX.18  
1503-XX.20



1503-47.FR-ZZ shown

XX = Denotes handle style

| Handle Series | Dim. A          |
|---------------|-----------------|
| 33            | 13-15/16" [354] |
| 34            | 9-5/16" [236]   |
| 35            | 14" [355]       |
| 46            | 13-13/16" [351] |
| 47            | 9-3/4" [248]    |
| 48            | 13-1/4" [337]   |
| 48X           | 10" [254]       |
| 55            | 13-5/8" [346]   |
| 60            | 9-1/2" [242]    |
| 61            | 13-5/16" [338]  |
| 61XD          | 9-3/4" [247]    |
| 64            | 13-7/8" [352]   |
| 68            | 13-5/8" [346]   |

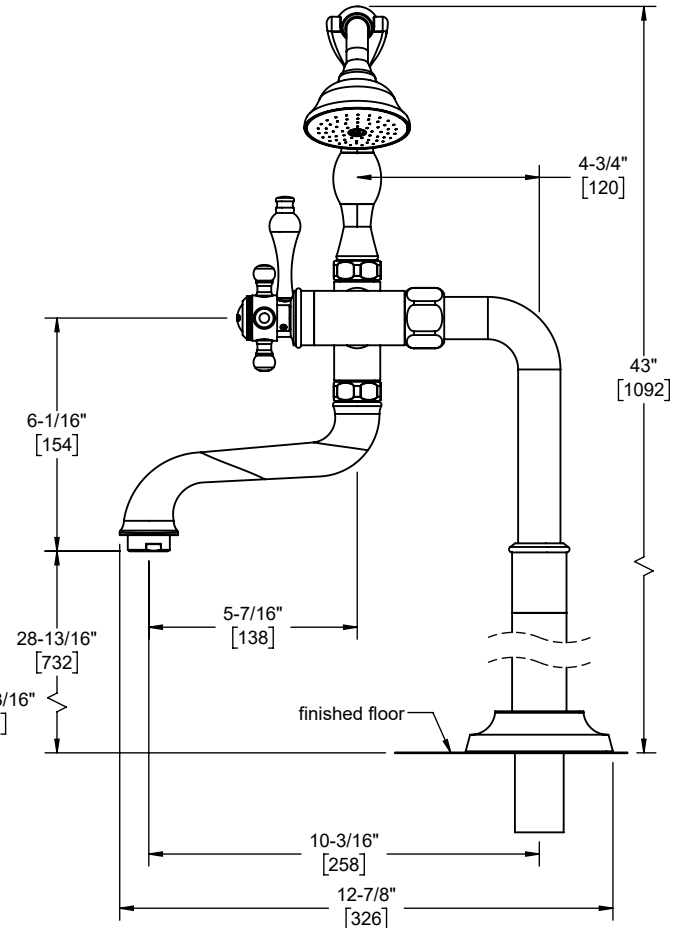
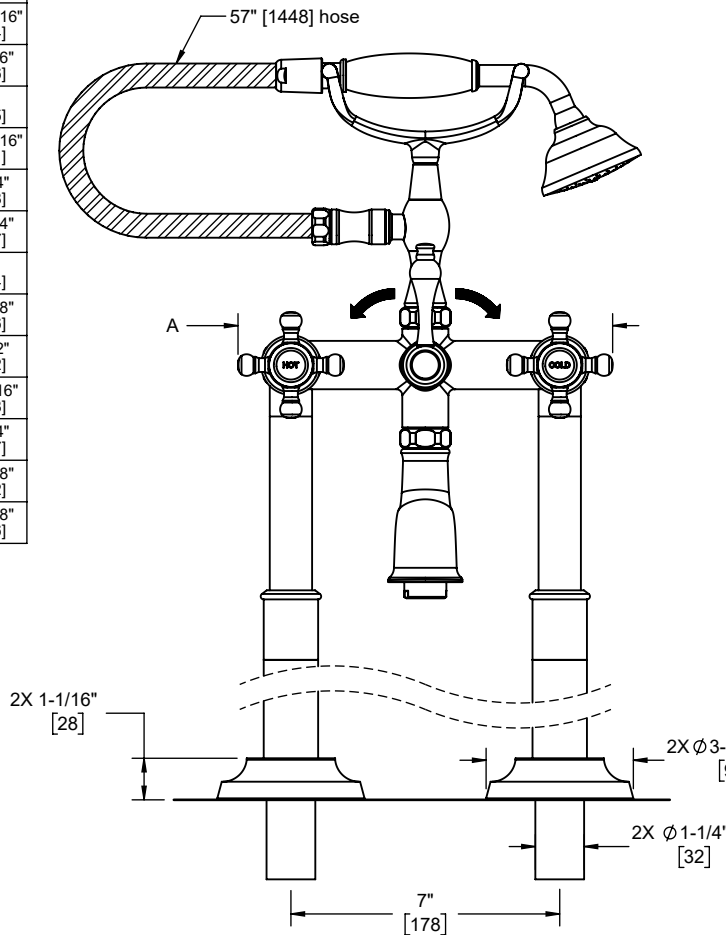

- (8X) - Concrete tri-lobe anchor
- (8X) - #10 X 2" stainless steel screw

| Through-Hole Specifications |                |               |
|-----------------------------|----------------|---------------|
| Min                         | Recommended    | Max           |
| Ø 1-1/4" [32]               | Ø 1-5/16" [33] | Ø 1-1/2" [38] |

Dimensions are inches, rounded to 1/16"  
[Dimensions in brackets are mm, rounded to 1mm]

Specifications subject to change without notice