

California Faucets®

CONTEMPORARY WALL MOUNT TUB FILLER WITH HANDSHOWER

Asilomar®

Features

- Tub filler maximum flow rate: 15 gpm (58.6 L/min) at 60 psi
- Handshower flow rate 2.0 gpm (7.6 L/min) or 1.8 gpm (6.8 L/min)
- 1/4 turn ceramic disc cartridges
- All brass construction
- Over 30 finishes including 15 PVD finishes

Codes/Standards Applicable

Product meets or exceeds the following:

- ASME A112.18.1/CSA B125.1
- CEC (1.8 gpm) / DOE (2.0 & 1.8 gpm)
- Commonwealth of MA
- EPA WaterSense handshower (2.0 gpm)
- ADA compliant (with lever handles)
- Local codes may require installation of an upstream tempering valve

1106-XX.20  
1106-XX.18

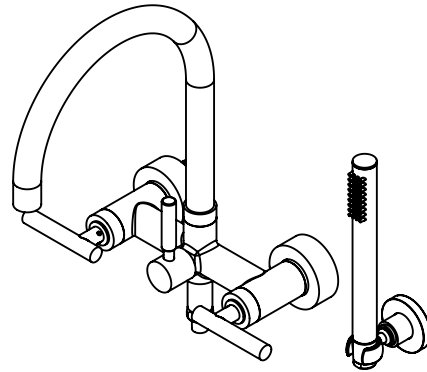

1106-66.FR SHOWN



XX = DENOTES HANDLE SERIES

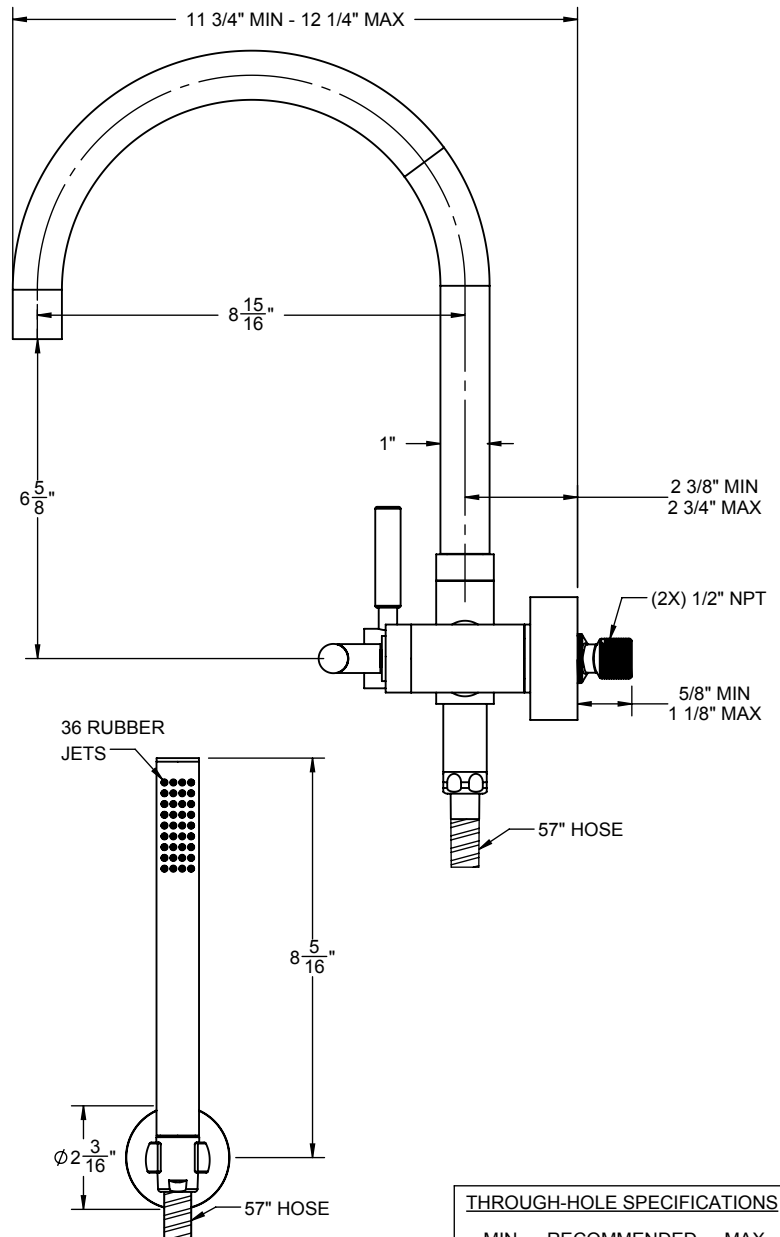
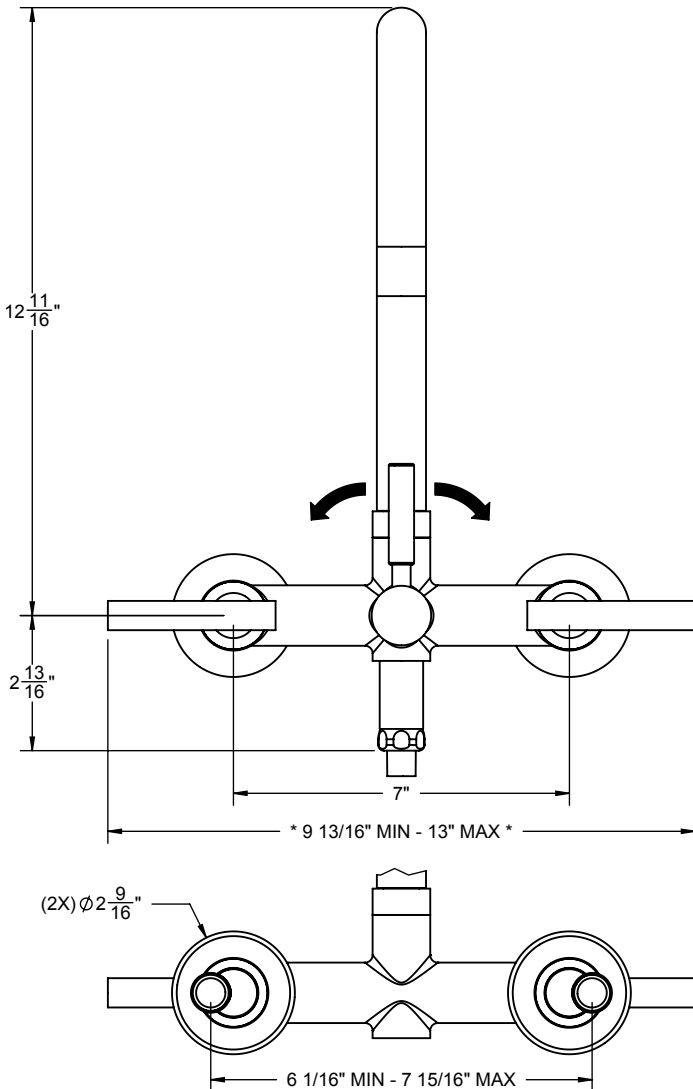

\* = DIMENSION VARIES BASED ON HANDLE SERIES

- (1X) PLASTIC #8-10 FINNED ANCHOR
- (1X) #10 X 2 STAINLESS STEEL SCREW

THROUGH-HOLE SPECIFICATIONS		
MIN	RECOMMENDED	MAX
Ø 1-13/16"	Ø 1-7/8"	Ø 2"

SPECIFICATIONS SUBJECT TO CHANGE WITHOUT NOTICE

ALL DIMENSIONS SHOWN TO NEAREST 1/16"