

Installation

**Heat Trace Combination
Drench Shower and
Eyewash Unit (includes
120 V and 208/240 V
versions)**

S19-304D2

**Top or Bottom Supply
Class I, Division 2, Groups B, C and D**

S19-304C2

**Top or Bottom Supply
Class II, Division 1 and 2,
Groups E, F and G**

Table of Contents

Pre-Installation Information	2-3
Components	4
Supplies Required	4
Dimensions	5
Secure Unit to Floor	6
Connect Water Supply	6
Assemble Components	6
Connect Electrical Supply	7
Conduit Seals	7
Wiring Diagrams	8
Troubleshooting	9



WARNING

Flush the water supply lines before beginning installation and after installation is complete. Test the unit for leaks and adequate water flow.

Main water supply to the unit should be "ON" at all times unless system is being serviced. Provisions shall be made to prevent unauthorized shutoff.

Power supplied to the unit should be 120VAC or 208-240VAC, 50-60 Hz, 15 amp branch circuit with a dedicated circuit breaker or fuse and should not supply power to any other device. Compliance and conformity to local codes and ordinances is the responsibility of the installer.

Do not use this safety equipment in a location that does not match its hazardous location rating. Verify the appropriate ratings prior to installation.

When making electrical connections be sure to follow all lockout-tagout safety procedures.

CAUTION

Emergency equipment must be supplied with tepid water (60-100°F/15.6-37.8°C). Any prolonged exposure to near freezing water affects the body's ability to maintain body temperature, increasing the risk of hypothermia.

The unit must be supplied with clean, potable water.

NOTICE

Before installing this product ensure that there are adequate clearances around the product and activation of the product does not interfere with other products or obstructions.

It is recommended that all water supply and electrical connections be made at temperatures above freezing. Failure to do so may result in major product and/or property damage.

Constant power supply to the safety equipment is necessary for it to function.

Avoid cleaners containing organic solvents, alcohols and hydrocarbons. Rinse with potable water after cleaning.

IMPORTANT

The installation and location of all safety drench showers, eye and eye/face washes must comply with the requirements of ANSI/ISEA Z358.1.

Read this installation manual completely to ensure proper installation, then file it with the owner or maintenance department. Compliance and conformity to local codes and ordinances is the responsibility of the installer.

Separate parts from packaging and make sure all parts are accounted for before discarding any packaging material. If any parts are missing, do not begin installation until you obtain the missing parts.

Installation and maintenance of this system must be completed by a qualified plumber and electrician according to the information contained in this installation manual and in compliance with all national and local codes.

The ANSI/ISEA Z358.1 standard requires an uninterrupted supply of flushing fluid. Bradley plumbed emergency fixtures require a minimum of 30 PSI (0.21MPa) flowing pressure. Flushing should be tepid per ANSI Z358.1

Weekly activation must be conducted on all plumbed emergency equipment to ensure a suitable flushing fluid supply is present and any sediment build up in the supply line is cleared. Inspect safety equipment monthly to address any maintenance issues ensuring the equipment is in good operating condition and that there are no signs of wear.

Perform functional test upon relocation of safety equipment.

The inspection and testing results of this equipment should be recorded weekly to verify proper operation. This equipment should be inspected annually to ensure compliance with ANSI Z358.1.

Workers who may come in contact with potentially hazardous materials should be trained regarding the placement and proper operation of emergency equipment per ANSI/ISEA Z358.1.

For questions regarding the operation or installation of this product, visit www.bradleycorp.com or call 800-BRADLEY (272.3539).

Product warranties and parts information may also be found under "Products" on our web site at bradleycorp.com.

Components

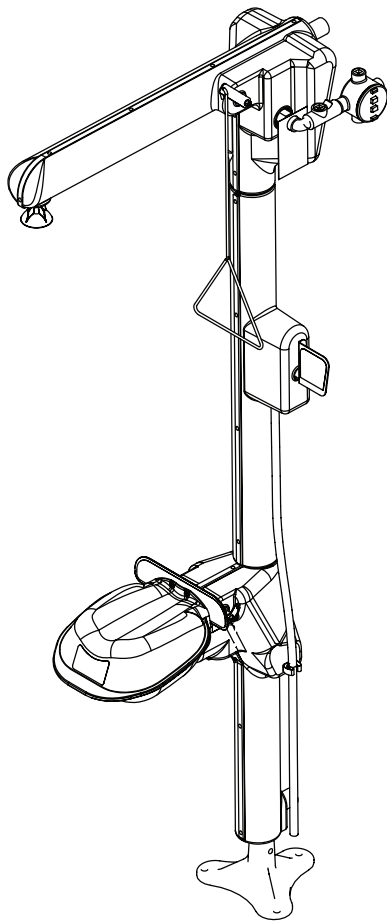

Heat Trace Unit
S19-304T (top supply)
S19-304B (bottom supply)

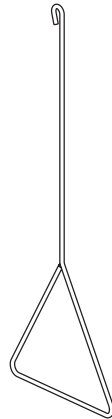

Pull Rod
128-156G

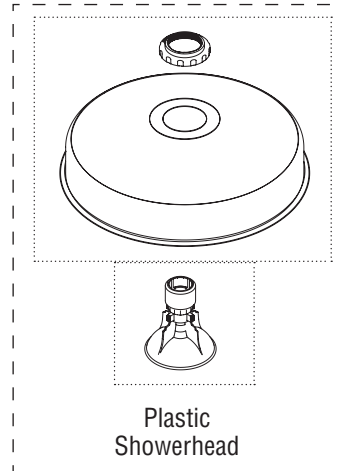

Plastic
Showerhead

Optional Shower
Shroud and
Retaining Nut



Stainless Steel
Showerhead

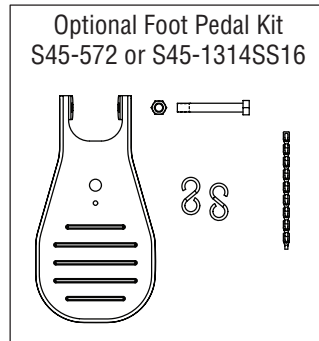

Optional Foot Pedal Kit
S45-572 or S45-1314SS16

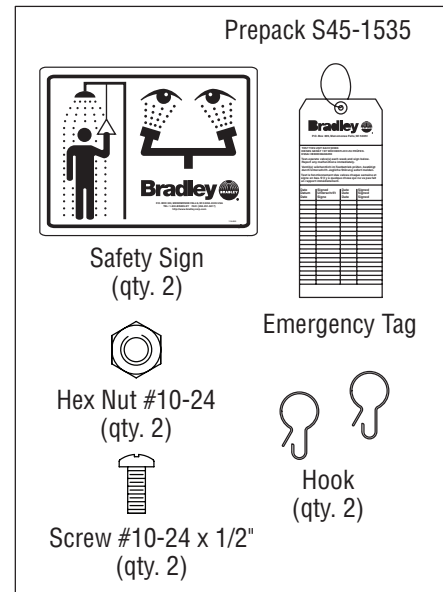

Prepack S45-1535



Safety Sign
(qty. 2)

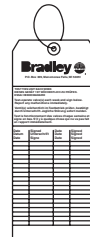

Emergency Tag



Hex Nut #10-24
(qty. 2)



Hook
(qty. 2)



Screw #10-24 x 1/2"
(qty. 2)

Supplies Required

- (3) 3/8" floor anchors and bolts
- Teflon tape and pipe sealant
- 30 PSI (2.0 bar) min/90 PSI (6.1 bar) max flow pressure
- 125 PSI (8.6 bar) max static pressure
- Piping to 1-1/4" NPT water supply inlet (30-90 PSI/ 2.0-6.1 bar)
- Piping to 1-1/4" NPT drain outlet on unit (if included with unit)
- Adequate supply pipe supports
- Provisions to dispose of shower and eye or eye/face wash waste water (minimum 30 gallons/115 liters) should be made (minimum 4" (120mm) drain)
- Optional: sign-mounting hardware
- Optional: for extension cable option, pipe insulation and protective coating are required

NOTICE! Bottom supply units have provisions for supporting the top of the unit. The 1-1/4" NPT solid pipe protruding from the shell must be used to support the unit.

Dimensions



Optional Class I, Division 2 and Class II indicator light will require 14" clearance from top of unit if installed in junction box top conduit hub.

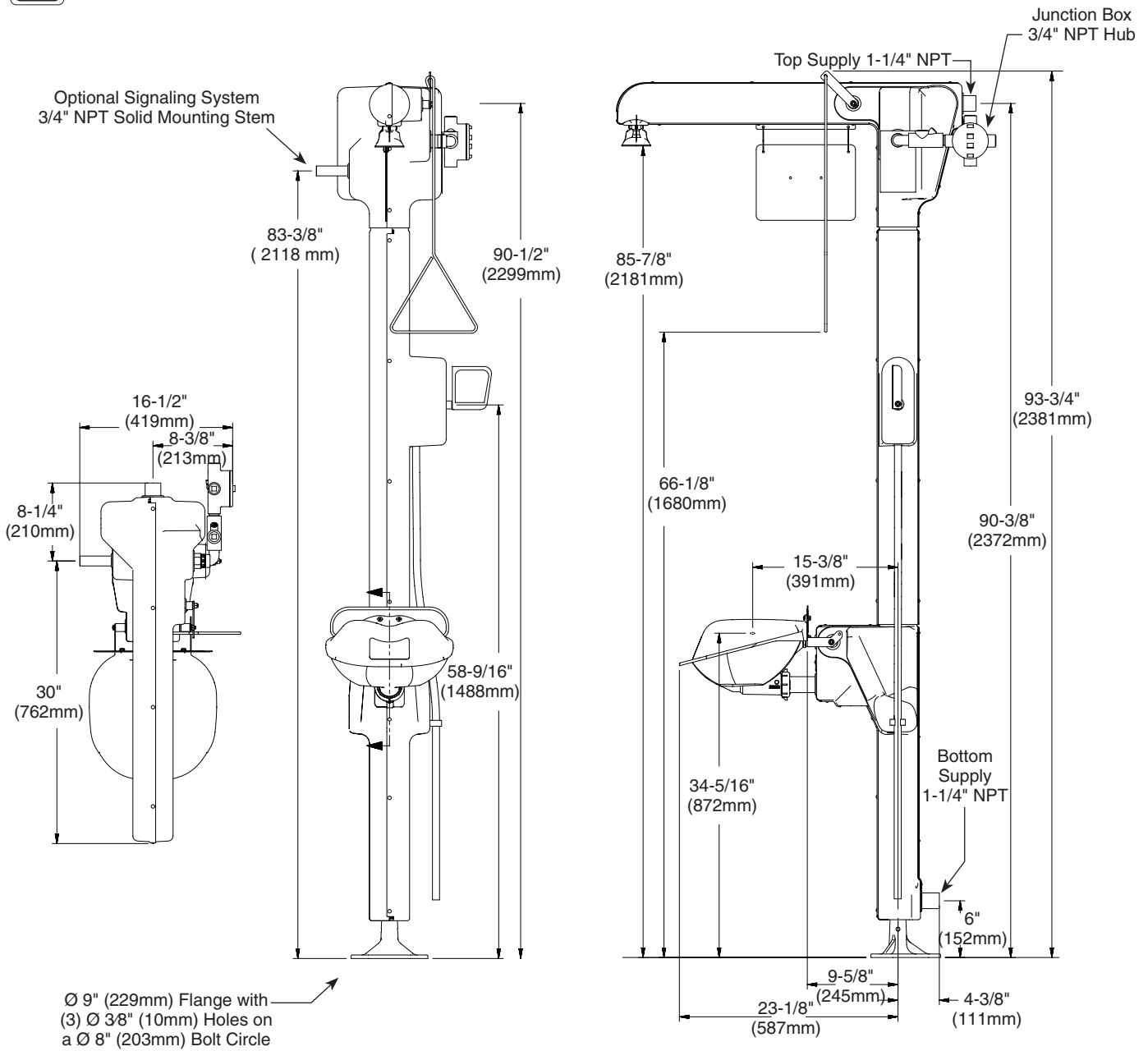

1 Secure Unit to Floor

NOTICE! Do not rely on the unit to support supply piping.

A Install three suitable anchors (supplied by installer) for 3/8" bolts in the floor.

B Bolt the base to the floor anchors using 3/8" bolts (supplied by installer)

C Install the pull rod to the unit as shown.



For optional foot pedal installation, the base must be positioned so that the hole in the base is perpendicular to the user.

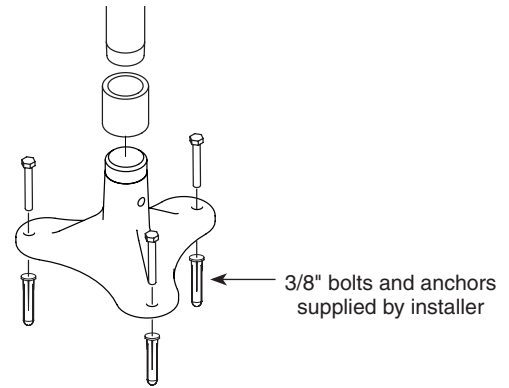

2 Connect Water Supply

NOTICE! Unit requires a minimum 30 GPM to operate and a minimum 30 PSI of flowing water pressure. Preferred flowing water pressure is 40-60 PSI. Water supply to the unit must be freeze-protected (by others).

NOTICE! Pipe size should be no smaller than 1-1/4" (supplied by installer).

A Connect the water supply piping to the 1-1/4" NPT inlet on the unit, see dimensions (piping by installer). Use pipe hangers or other means to provide adequate supports for the supply pipe (supports by installer).

B Open water supply lines and test for leaks and adequate water flow.

NOTICE! In extreme cold weather, run water long enough to warm non-freeze protected components of the unit to allow proper drainage.

3 Assemble Components

A Install the showerhead to the unit as shown. The bottom edge of the showerhead should be 85-7/8" (2181mm) from the floor.

B Mount the safety signs to the wall or to the unit if desired. Use the screws, nuts and hooks provided to hang the signs back-to-back on the unit.

C If optional foot pedal kit is ordered, attach foot pedal to Halo handle per foot pedal installation instructions.

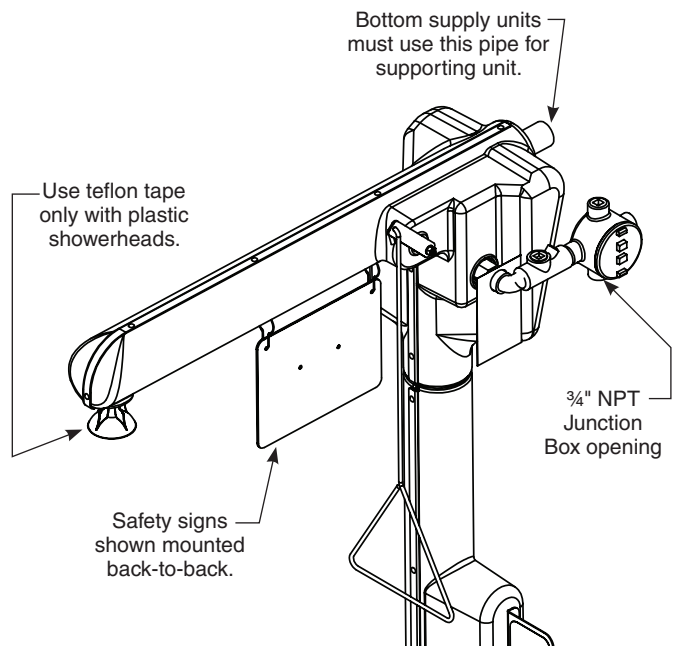

4 Connect Electrical Supply



Average power consumption of the unit is .7 amp/80 watts at 120VAC (.40 amp/80 watts at 208 VAC or 0.35 amp/80 watts at 240 VAC) at 50°F (10°C) internal unit temperature. Unit ordered with extension cable: average power consumption of the unit is 1.1 amp/125 watts at 120 VAC (0.55 amp/125 watts at 240 VAC) at 50°F (10°C) internal unit temperature. Refer to the installation instructions provided with the signaling system for more information.

A

Connect the power to the junction box on the unit as shown in the schematic. (junction box accepts 3/4" conduit fitting, supplied by installer)

B

Connect the optional industrial control panel signaling system and indicator light. The indicator light can be added to any open conduit hub in the junction box. Hardware for mounting signaling system to heat trace stem is provided with signaling system. Refer to the appropriate option's installation guide for wiring diagram.

C

If optional extension cable is ordered with unit, it will need to be attached to the facilities pipe with fiberglass tape (included, part number 269-2587), insulated, and a protective coating applied (supplier provided). Supplier provided components are not covered under the unit's certification listing. Extension cable is pre-powered through the system.

⚠ CAUTION Any electrical components supplied by installer must match the rating of the fixture to maintain its integrity.



Heat trace cable protects the unit's plumbing from freezing down to -50°F (-46°C) when properly installed.

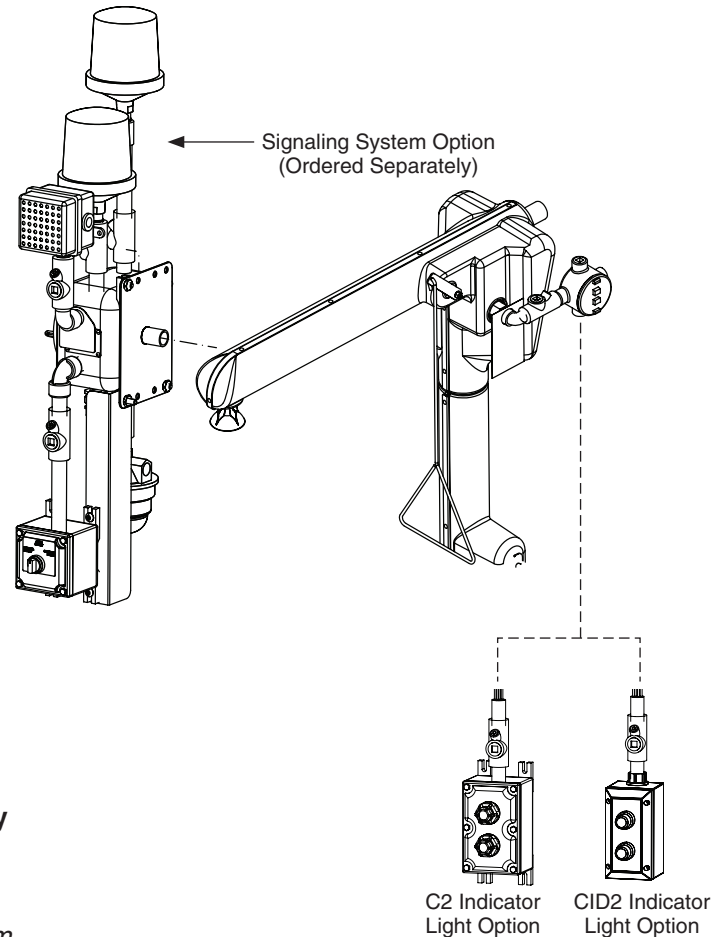

5 Conduit Seals

A

Unit is provided with sealing compound and conduit seals. Seals must be filled by installer prior to powering the unit per seal manufacturer's instructions.

Wiring Diagrams

S19-304C1D2 & C2 Without Options

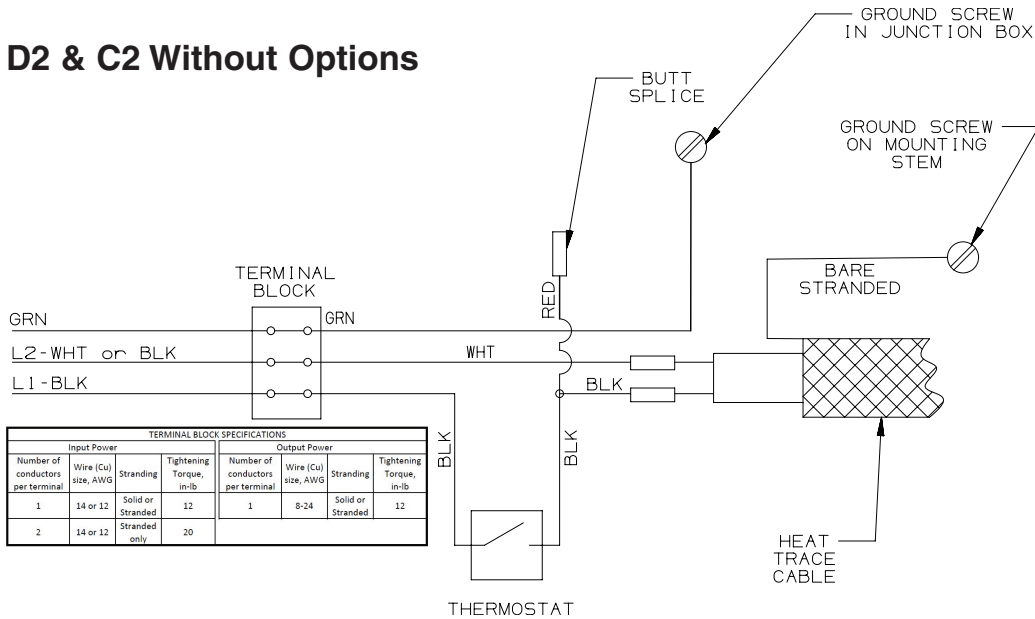

S19-304C1D2 & C2 With Options

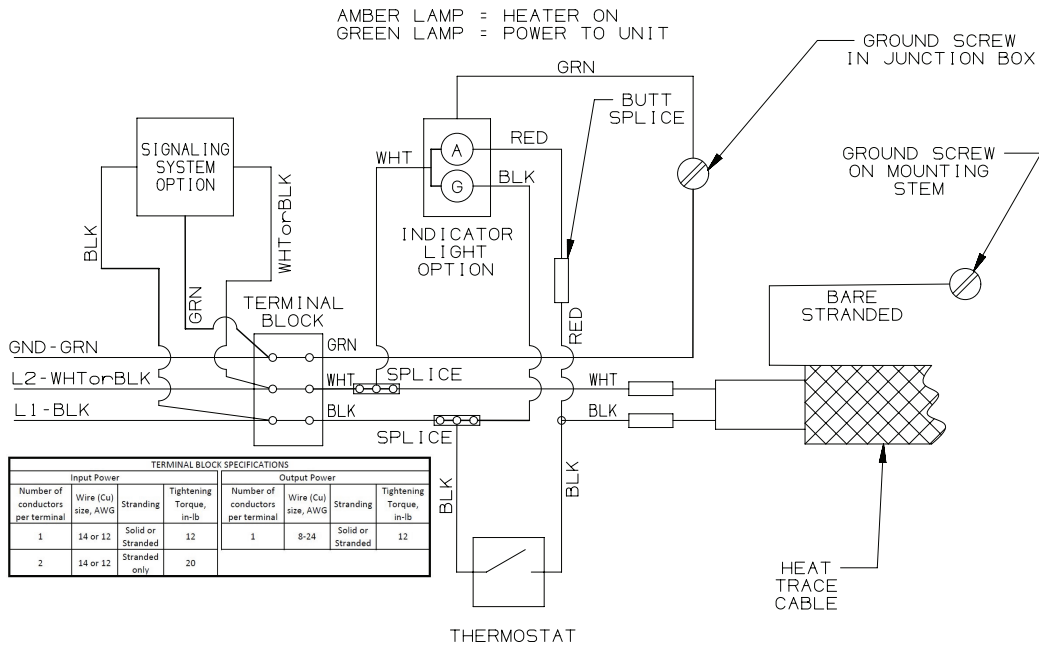

Troubleshooting

Problem	Cause	Solution
Low water flow at drench shower and eyewash	Insufficient pressure Undersized supply piping	Minimum 30 GPM required Increase pressure/pipe size
Low water flow at drench shower or eye wash	Debris in system	Disassemble the showerhead, clean and reassemble Unscrew the eyewash heads from the yoke, clean and reassemble. If still clogged, replace the heads.
Freeze-protection valve is flowing water	Power supply is off [if the water temperature from the valve is below 40°F (4°C)]	Turn the power on.
	Water supply is too cold	Make sure the unit is supplied with tempered water.
	Defective thermostat [if the water temperature from the valve is below 40°F (4°C)]	Check continuity and replace if check fails activates at 50°F (10°C) (factory-set).
	Defective freeze valve [if the water temperature from the valve is above 40°F (4°C)]	Replace the freeze valve NOTE: A water supply that is at least 40°F (4°C) or colder will hold the freeze bleed valve open. To close the valve: <ol style="list-style-type: none"> 1. turn the water off temporarily or plug the valve until the heat trace unit's heat warms the valve 2. increase the surface temperature of the valve to above 40°F (4°C) by immersing the valve in hot water IMPORTANT: Make sure that the heat trace unit is operating properly before plugging the freeze bleed valve. A plugged valve will not provide backup freeze protection should the heat trace unit fail.
Scald-protection valve is flowing water	Defective scald valve [if the water temperature from the valve is below 80°F (27°C)]	Replace the scald valve.
	Direct sunlight or high ambient temperature	Cool the unit.
	Defective thermostat	Check continuity and replace if check fails activates at 50°F (10°C) (factory-set).