

Residential Atmospheric Vent Fan Assist Gas Water Heater



Photo is of
RG2F40S6N

FEATURING:



The Fan Assist FVIR Defender Safety System[®] Models Feature:

- **ENERGY STAR[®] Qualified**—Meet or exceed requirements for ENERGY STAR[®] per the latest ENERGY STAR[®] criteria revision, as well as most utility rebate programs.
- **High Efficiency Blower**—Pulls air through a tightly restricted baffle system resulting in increased water heater efficiency ratings.
 - **Ten Foot Power Cord**—Included (120 VAC).
- **Bradford White ICON System[™]**—Intelligent gas control with spark to pilot ignition system eliminates the constant burning pilot. This results in savings of pilot gas during standby periods (120 VAC).
 - **Enhanced Performance**—Proprietary algorithms provide enhanced First Hour Rating and tighter temperature differential.
 - **Advanced Temperature Control System**—Microprocessor constantly monitors and controls burner operation to maintain consistent and accurate water temperature levels.
 - **Intelligent Diagnostics**—An exclusive green LED light prompts the installer during start-up and provides ten different diagnostic codes to assist in troubleshooting.
 - **Pilot On Indication**—Flashing green LED provides positive indication that pilot is on.
 - **Separate Immersed Thermowell**—High-strength advanced polymer composite thermowell provides isolation between electric temperature sensor and surrounding water. No need to drain the tank when removing gas valve.
- **Advanced ScreenLok[®] Technology Flame Arrestor Design**—Flame arrestor is designed to prevent ignition of flammable vapors outside of the water heater.
- **Flammable Vapor Sensor**—Electronic sensor prevents burner operation if flammable vapors are detected.
- **Maintenance-Free**—No regular cleaning of air inlet openings or flame arrestor is required under normal conditions.
- **Sight Window**—Offers a view into the combustion chamber to observe the operation of the pilot and burner.
- **Factory-Installed Hydrojet[®] Total Performance System**—Sediment reducing device that also increases first hour rating of hot water while minimizing temperature build-up in tank.
- **Vitraglas[®] Lining**—An exclusively engineered enamel formula that provides superior tank protection from the highly corrosive effects of hot water. This formula (Vitraglas[®]) is fused to the steel surface by firing at a temperature of over 1600°F (871°C).
- **Insulation System**—2" (51mm) Non-CFC foam insulation covers the sides and top of the tank, reducing heat loss. This results in less energy consumption, improved efficiencies, and jacket rigidity.
- **Pedestal Base.**
- **Water Connections**—3/4" (19mm) NPT factory-installed true dielectric fittings extend water heater life and simplify water line connections.
- **Factory-Installed Heat Traps**—Design incorporates a flexible disk that reduces heat loss in piping and eliminates the potential for noise generation.
- **Protective Magnesium Anode Rod.**
- **3x4 "Snap Lock" Draft Diverter**—Allows either 3" (76mm) or 4" (102mm) vent connections.
- **T&P Relief Valve**—Installed.
- **Low Restrictive Brass Drain Valve**—Durable tamper proof design.
- **NOx Emissions**—Less than 40 ng/J.



6 or 10-Year Limited Tank Warranties / 6 or 10-Year Limited Warranty on Component Parts.

For more information on warranty, please visit www.bradfordwhite.com
For products installed in USA, Canada, and Puerto Rico. Some states do not allow limitations on warranties. See complete copy of the warranty included with the heater.

Residential Atmospheric Vent Fan Assist Gas Water Heater

Fan Assist Models

NATURAL GAS AND LIQUID PROPANE GAS

Meet or exceed ASHRAE 90.1b (current standard) C.E.C. Listed
78% Recovery Efficiency

| Model Number | Nominal Gal. Capacity | | DOE Rated Storage Volume (Gal.) | BTU/Hr. Input | LP BTU/Hr. Input | First Hour Rating (Gal.) | Uniform Energy Factor | Recovery at 90°F Rise* | | | | Model Number | Nominal Liter Capacity | DOE Rated Storage Volume (Liters) | kW Input | LP kW Input | First Hour Rating (Liters) | Uniform Energy Factor | Recovery at 50°C Rise* | |
|--------------|-----------------------|-----------|---------------------------------|---------------|------------------|--------------------------|-----------------------|------------------------|----------|----------|----------|--------------|------------------------|-----------------------------------|----------|-------------|----------------------------|-----------------------|------------------------|------------------|
| | U.S. Gal. | Imp. Gal. | | | | | | U.S. GPH | Imp. GPH | U.S. GPH | Imp. GPH | | | | | | | | U.S. Liters/Hour | Imp. Liters/Hour |
| ★ RG2F40S6N | 40 | 33 | 38 | 38,000 | 38,000 | 62 | 0.64 | 41 | 33 | 40 | 33 | ★ RG2F40S6N | 151 | 144 | 11.1 | 11.1 | 235 | 0.64 | 155 | 151 |
| ★ RG2F50S6N | 50 | 42 | 48 | 38,000 | 38,000 | 76 | 0.68 | 41 | 33 | 40 | 33 | ★ RG2F50S6N | 189 | 182 | 11.1 | 11.1 | 288 | 0.68 | 155 | 151 |

| Model Number | A Floor to Exhaust Conn. in. | B Jacket Dia. in. | C Vent Size in. | D Floor to T&P Conn. in. | E Floor to Gas Conn. in. | F Floor to Top of Heater in. | G Floor to Water Conn. in. | H Depth in. | J C/L of Water Conn. in. | M Water Conn. NPT in. | S Gas Conn. Size in. | Approx. Shipping Weight lbs. |
|--------------|--------------------------------|-------------------|-----------------|--------------------------------|--------------------------|------------------------------|--------------------------------|--------------------------------|--------------------------|-----------------------|----------------------|------------------------------|
| ★ RG2F40S6N | 54 ¹ / ₄ | 22 | 3 or 4 | 40 | 13 | 47 | 47 ⁷ / ₈ | 25 ⁷ / ₈ | 8 | 3/4 | 1/2 | 150 |
| ★ RG2F50S6N | 55 ¹ / ₄ | 24 | 3 or 4 | 40 ⁵ / ₈ | 13 | 48 | 48 ⁷ / ₈ | 27 ⁷ / ₈ | 8 | 3/4 | 1/2 | 176 |

| Model Number | A Floor to Exhaust Conn. mm. | B Jacket Dia. mm. | C Vent Size mm. | D Floor to T&P Conn. mm. | E Floor to Gas Conn. mm. | F Floor to Top of Heater mm. | G Floor to Water Conn. mm. | H Depth mm. | J C/L of Water Conn. mm. | M Water Conn. NPT mm. | S Gas Conn. Size mm. | Approx. Shipping Weight kg. |
|--------------|------------------------------|-------------------|-----------------|--------------------------|--------------------------|------------------------------|----------------------------|-------------|--------------------------|-----------------------|----------------------|-----------------------------|
| ★ RG2F40S6N | 1378 | 559 | 76 or 102 | 1016 | 330 | 1194 | 1216 | 657 | 203 | 19 | 13 | 68 |
| ★ RG2F50S6N | 1403 | 610 | 76 or 102 | 1032 | 330 | 1219 | 1241 | 708 | 203 | 19 | 13 | 80 |

Propane models feature a Titanium Stainless Steel propane burner. For Propane (LP) models change suffix "N" to "X".

For 10 year models, change suffix from "6" to "10".

* Based on manufacturer's rated recovery efficiency.

120V, 60Hz., 1 Amp.

Uniform Energy Factor and First Hour Rating is based on the latest AHRI directory listings.

★ = ENERGY STAR® Qualified. 

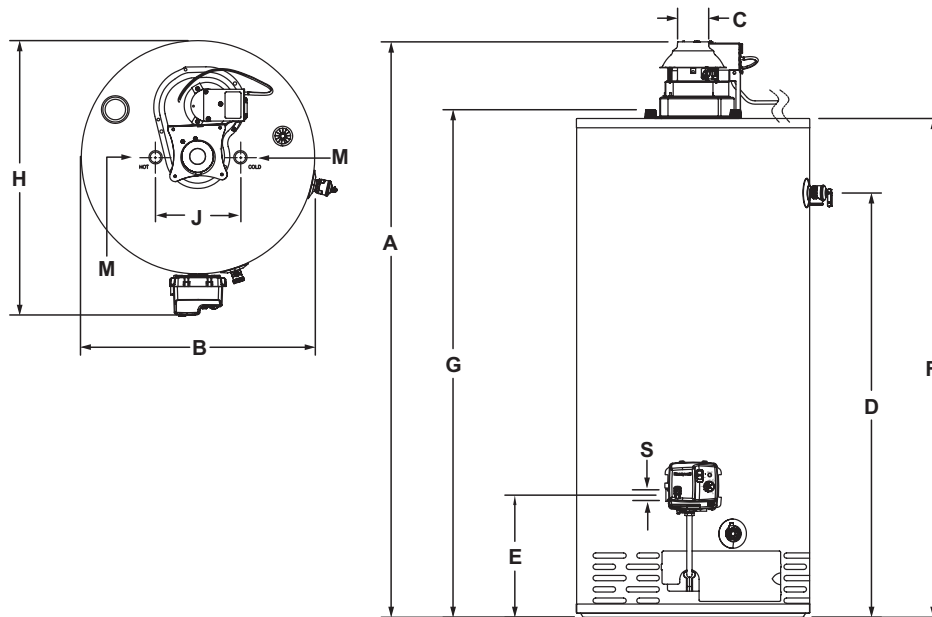

General:

Meets NAECA Requirements.

All gas water heaters are certified at 300 PSI test pressure (2068 kPa) and 150 PSI working pressure (1034 kPa). All potable water connections are 3/4" NPT (19mm) on 8" (203mm) centers. All models design-certified by CSA International (formerly AGA/CGA), ANSI Z21.10.1 and peak performance rated.

Dimensions and specifications subject to change without notice in accordance with our policy of continuous product improvement.

Suitable for Water (Potable) Heating and Space Heating. Toxic chemicals, such as those used for boiler treatment, shall NEVER be introduced into the potable side of this system. The potable side may NEVER be connected to any existing heating system or component(s) previously used with a non-potable water heating appliance.

— BRADFORD WHITE IS —



For field service, contact your professional installer or local Bradford White sales representative.

Sales 800-523-2931 ■ Fax 215-641-1612

Technical Support 800-334-3393 ■ Email techserv@bradfordwhite.com

Warranty 800-531-2111 ■ Email warranty@bradfordwhite.com

International: Telephone 1-215-641-9400 ■ Email international@bradfordwhite.com / www.bradfordwhite.com

Built to be the Best™