

Residential PowerStor2™ Series® Double-Wall Indirect Water Heater



Photo is of
DW-2-50-L

The PowerStor2™ Series® Double-Wall Models feature:

- **Heat Exchanger**—Double wall 1½" O.D. glass coated (Vitrageas[®]) steel coil. The positive leak path between the two walls of the coil ensures the potable water will stay separate from the hydronic fluid.
- **Low Heat Exchanger Head Loss**—Up to 10 GPM flow, with less than 5 ft. of head loss. Greatly reduces the required pump size for heat exchange.
- **Factory installed Hydrojet[®] Total Performance System**—Cold water inlet sediment reducing device helps to minimize sediment build up in tank. Increases first hour delivery of hot water while minimizing temperature build up in tank.
- **Vitrageas[®] Lining**—Bradford White tanks are lined with an exclusively engineered enamel formula that provides superior tank protection from the highly corrosive effects of hot water. This formula (Vitrageas[®]) is fused to the steel surface by firing at a temperature of over 1600°F (871°C).
- **Fully Automatic Controls**—Fast acting surface-mount thermostat for automatic temperature control.
- **Supply and Return Connections**—The 3/4" NPT female connections are located on the front for both the boiler supply and boiler return.
- **2" Non-CFC Foam Insulation**—Covers the sides and top of tank, reducing the amount of heat loss. This results in less energy consumption, improved operation efficiencies and jacket rigidity.
- **Potable Water Connections**—3/4" NPT factory installed true dielectric fittings extend water heater life and eases installation.
- **Two Protective Aluminum Rods**—Provide added protection against corrosion for long trouble-free service.
- **Steel Tank**—Heavy gauge steel automatically formed, rolled and welded to assure a continuous seam for glass lining.
- **T&P Relief Valve**—Included.
- **Low Restriction Brass Drain Valve**—Durable tamper proof design.
- **AHRI Certified**—These water heaters are rated by the Air-Conditioning, Heating, and Refrigeration Institute to provide accurate performance data within the standards of the certification. This certification provides a recognized standard for proper comparison of hydronic appliances.



Limited Lifetime Tank and Heat Exchanger Warranties / 6-Year Limited Warranty on Component Parts.

For more information on warranty, please visit www.bradfordwhite.com

For products installed in USA, Canada and Puerto Rico. Some states do not allow limitations on warranties. See complete copy of the warranty included with the heater.

Residential PowerStor2™ Double Wall Indirect Water Heater

Double Wall Indirect Models

Meet or exceed ASHRAE 90.1b (current standard)

Model Number	Capacity		A Floor to Heater Top	B Jacket Dia.	C Floor to T&P Conn.	D Floor to Water Conn.	E Floor to Exchanger Outlet	F Floor to Exchanger Inlet	G Floor to Thermostat	Approx. Shipping Weight
	U.S. Gal.	Imp. Gal.	in.	in.	in.	in.	in.	in.	in.	
DW-2-40-L	38	32	41	22	34%	41%	5%	27½	11½	195
DW-2-50-L	48	40	46¼	22	40%	47%	5%	27½	11½	205
DW-2-65-L	64	54	59	22	53%	60	5%	27½	11½	235
DW-2-80-L	75	63	59	24	52%	59%	5%	27½	11½	255

Model Number	Capacity		A Floor to Heater Top	B Jacket Dia.	C Floor to T&P Conn.	D Floor to Water Conn.	E Floor to Exchanger Outlet	F Floor to Exchanger Inlet	G Floor to Thermostat	Approx. Shipping Weight
	Liters	mm.	mm.	mm.	mm.	mm.	mm.	mm.	mm.	
DW-2-40-L	144	1045	559	873	1083	137	699	292	89	
DW-2-50-L	182	1175	559	1019	1200	137	699	292	93	
DW-2-65-L	242	1505	559	1349	1527	137	699	292	107	
DW-2-80-L	284	1505	610	1343	1518	137	699	292	116	

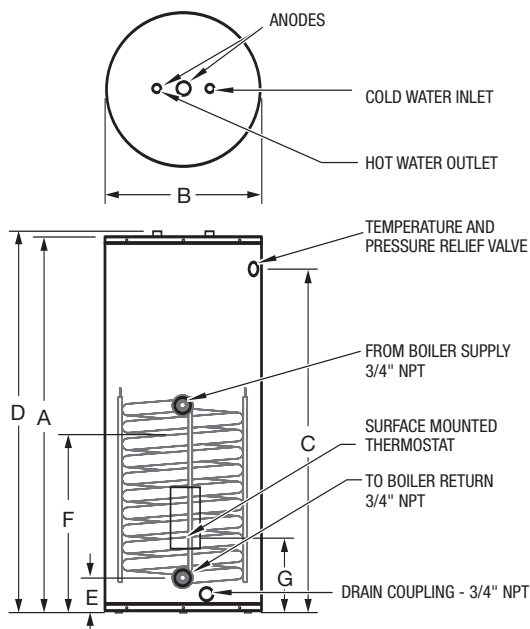

AHRI Certified Water Heater Ratings

Model	First Hour Rating @ 135°F (Gal.)	Continuous Draw Rating @ 135°F (Gal./Hr.)	Standby Heat Loss Rating (°F/Hr.)	Minimum Heat Req. Rate (BTU/Hr.)	Minimum Heat Source Flow Rate (Gal./Min.)
DW-2-40-L	123	98	1.1	65,000	8.0
DW-2-50-L	133	98	0.9	65,000	8.0
DW-2-65-L	148	98	0.7	65,000	8.0
DW-2-80-L	158	98	0.6	65,000	8.0

NOTES: These certified ratings were obtained with a heat source output rate and flow rate as specified and a 180° F boiler water supply temperature. Other results will be obtained under different conditions.

DOE Water Heater Performance

Model	Maximum First Hour Rating (Gal.) @		Continuous Draw Rating (Gal./Min.) @		Approximate Boiler Output Needed For Ratings (BTU/Hr.)
	140°F	115°F	140°F	115°F	
DW-2-40-L	80	122	0.9	1.6	55,000
DW-2-50-L	87	129	0.9	1.6	55,000
DW-2-65-L	96	138	0.9	1.6	55,000
DW-2-80-L	106	148	0.9	1.6	55,000

NOTES: Based on 200° F boiler water temperature and 50° F potable water inlet temperature.

Heat Exchanger Head Loss

GPM	2	5	8	10	12
Ft. of Hd. Loss	0.06	0.94	2.40	3.75	5.40

Meets NAECA Requirements

General

All units are certified at 300 PSI test pressure (2068 kPa) and 150 PSI working pressure (1034 kPa). All potable water connections are 3/4" NPT (19mm) on 8" (203mm) centers.

Dimensions and specifications subject to change without notice in accordance with our policy of continuous product improvement.

Suitable for Water (Potable) Heating and Space Heating.

Toxic chemicals, such as those used for boiler treatment, shall NEVER be introduced into the potable water side. The potable side of this unit may NEVER be connected to any existing heating system or component(s) previously used with a non-potable water heating appliance. The heat exchanger side of the unit may be used in space heating applications.



Ambler, PA

For U.S. and Canada field service, contact your professional installer or local Bradford White sales representative.

Sales 800-523-2931 • Fax 215-641-1670 / Technical Support 800-334-3393 • Fax 269-795-1089 • Warranty 800-531-2111 • Fax 269-795-1089

International: Telephone 215-641-9400 • Telefax 215-641-9750 / www.bradfordwhite.com

BRADFORD WHITE-CANADA INC. Sales / Technical Support 866-690-0961 / 905-238-0100 • Fax 905-238-0105 / www.bradfordwhite.com

Built to be the Best™

©2015, Bradford White Corporation. All rights reserved.