

For Commercial Applications

Job Name		Engineer / Architect	
Job Location		Wholesaler	
Submittal Date		Contractor	

WPS Series Wheel Chock

Use: Commercial food service applications with caster mounted equipment

Design Features:

- Compatible with 4", 5", and 6" casters
- Can be used for new or existing equipment
- Molded with a flame-retardant polymer blend
- Certified to NSF/ANSI Standard 169-Special Purpose Food Equipment & Devices
- Withstands 1,000 lbs of crush force

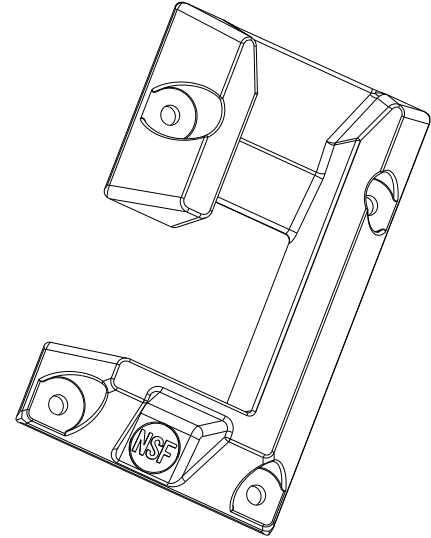

MATERIAL SPECIFICATIONS	
Wheel Chock	Polyamide
Mounting Screws	Steel, plated
Adhesive Foam Tape	Foam tape

PART DIMENSIONS (Inches)			
Model	DIM. A	DIM. B	DIM. C
WPS	4.75	7.63	1.50

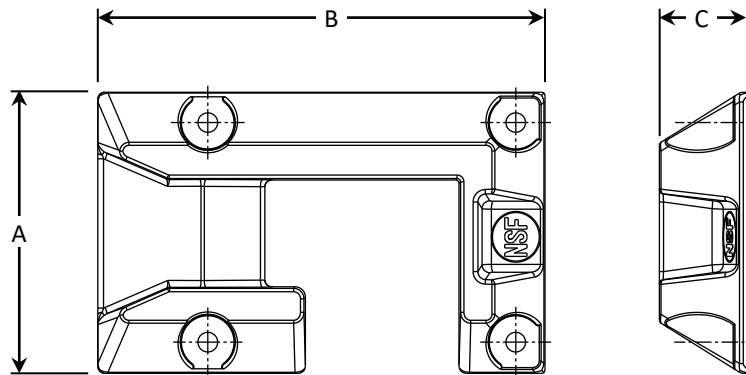

Part Listing:

- WPS Wheel Chock for Movable Appliances

Listings & Certifications

- Certified to NSF/ANSI Standard 169-Special Purpose Food Equipment & Devices

This specification and all information contained herein is the confidential and exclusive property of Brasscraft Manufacturing Company, and shall not be disclosed to others without the written consent of Brasscraft Mfg. Co. This specification must be returned to Brasscraft Mfg. Co. if requested.