

# TSP511 SPECIFICATIONS

## pure·2 floor-mounted thermostatic bath mixer with handshower

### FEATURES:

- Single-hole, floor-mounted thermostatic tubfiller with handshower & smooth 60" Neoperl shower hose with conical swivel connections
- 8¾" non-swivel spout projection with customized laminar flow
- Durable finish and sleek design

### SPECIFICATIONS:

Warranty:	Limited lifetime warranty (residential) One year warranty (commercial)
Connection:	¾" NPT
Material:	Brass body
Flow rate:	12.0 gpm @ 80 PSI handshower: 1.8 gpm @ 80 PSI
Weight:	28 lbs (13kg)
Shipping dimensions:	(LWH) 29" x 12" x 9" (730mm x 295mm x 225mm)*

### FINISHES:

Polished chrome

### INSTALLATION:

Install this product according to the installation guide. Our products must be installed by certified professionals only and according to our installation guide as well as federal, provincial/state and local building codes and regulations.

### CARE AND MAINTENANCE:

See Installation Manual

### CODES / STANDARDS APPLICABLE:

- Meets or exceeds ANSI / ASME standard A112.18.1 and CAN / CSA B125.1-05 requirements
- Listed with IAPMO bearing the UPC / cUPC mark
- California AB1953 compliant
- Calgreen compliant

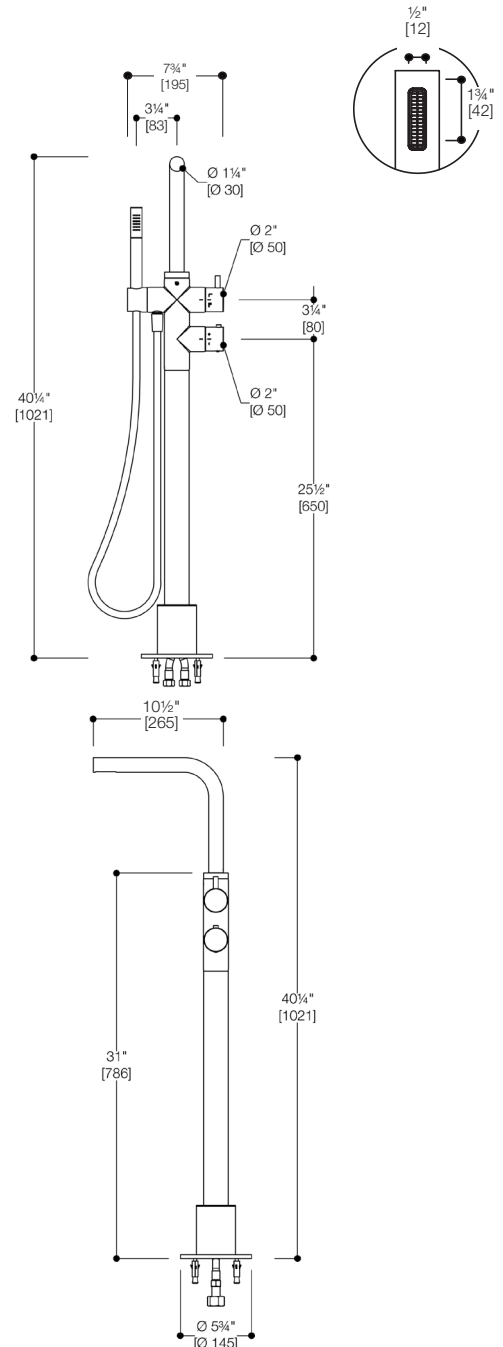

\*Approximate measurements for comparison only.  
Note: These dimensions and specifications are subject to change without notice.