

TSP141 SPECIFICATIONS

pure•2 deck-mounted basin mixer

FEATURES:

- Three-hole deck-mounted basin mixer with two lever handles
- Durable finish and sleek design
- Brass valve body
- 6½" spout projection with Neoperl laminar flow aerator
- Includes Flühs ceramic valves with redundant shut-offs for leak protection and long lasting reliability
- Less drain



SPECIFICATIONS:

Warranty:	Limited lifetime warranty (residential) One year warranty (commercial)
Connection:	½" NPT
Material:	Brass body
Flow rate:	1.2 gpm @ 60 PSI
Cartridge type:	Flühs ceramic
Weight:	7 lbs (3 kg)*
Shipping dimensions:	(LWH) 18" x 12" x 5" (460mm x 310mm x 120mm)*
FINISH:	Polished chrome

ACCESSORIES (sold separately):

- Recommend TW120 or TW121 push button waste

INSTALLATION:

Install this product according to the installation guide. Our products must be installed by certified professionals only and according to our installation guide as well as federal, provincial/state and local building codes and regulations.

CARE AND MAINTENANCE:

See Installation Manual

CODES / STANDARDS APPLICABLE:

- Meets or exceeds ANSI / ASME standard A112.18.1 and CAN / CSA B125.1-05 requirements
- Listed with IAPMO bearing the UPC / cUPC mark
- ADA compliant
- California AB1953 compliant
- Calgreen compliant

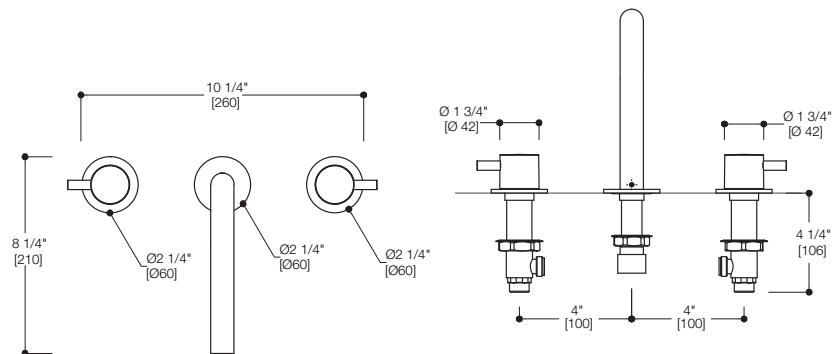
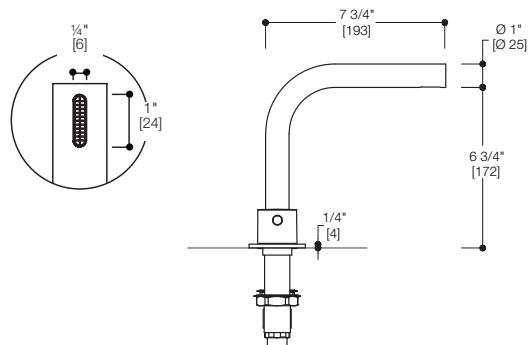
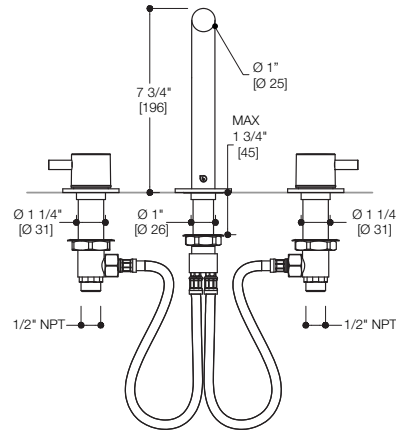

ADA **CALGreen** AB1953

*Approximate measurements for comparison only.
Note: These dimensions and specifications are subject to change without notice.