

TS920 SPECIFICATIONS

1/2" thermostatic tub/shower rough-in valve with 2-way diverter

FEATURES:

- Thermostatic tub/shower rough-in valve with 2-way diverter
- 2 ports, 2 functions: port 1 & port 2 are only operated individually
- Single-handle temperature control
- 1/2" NPT connection
- Integral service shut-offs with filter screens
- Crossflow prevention: temperature remains constant even if water pressure changes
- Anti-scald safety stop, preset to 100°F / 38°C
- Set and maintain precise desired temperature
- Ceramic cartridge & thermostatic cartridge
- Solid brass construction
- Mounting tabs for easy installation

SPECIFICATIONS:

| | |
|----------------------|--------------------------------------------------------------------------------------------|
| Warranty: | Limited lifetime warranty (residential) One year warranty (commercial) |
| Material: | Solid brass construction |
| Valve size: | 1/2" NPT |
| Flow rate: | 6.5 gpm @ 60 PSI (mixed hot + cold) (output will vary depending on device in operation) |
| Shipping weight: | 2.5 lbs (1.1 kgs) |
| Shipping dimensions: | (LWH) 8" x 8 1/4" x 6 1/4" (203mm x 209mm x 159mm)* |

REQUIRES:

- pure/2/opus/2 TSP920S or TSP920R valve trim (sold separately)

ACCESSORIES (SOLD SEPARATELY):

- Extension kits available for deep in-wall installation, PT4501 for thermostatic handle + PT4502 for volume control/diverter handle

INSTALLATION

Install this product according to the installation guide. Our products must be installed by certified professionals only and according to our installation guide as well as federal, provincial/state and local building codes and regulations.

CARE AND MAINTENANCE

See Installation Manual

CODES / STANDARDS APPLICABLE:

- Meets or exceeds ASME A112.18.1 and CSA
- Calgreen compliant

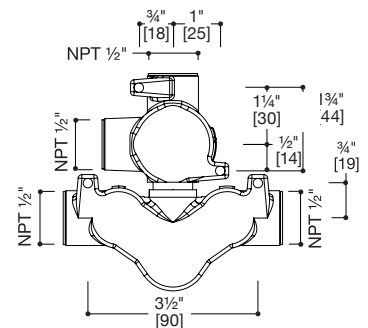
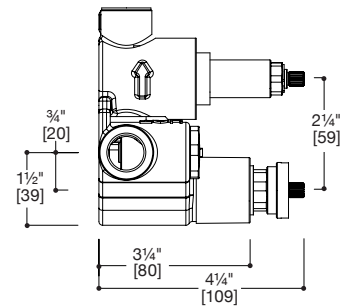
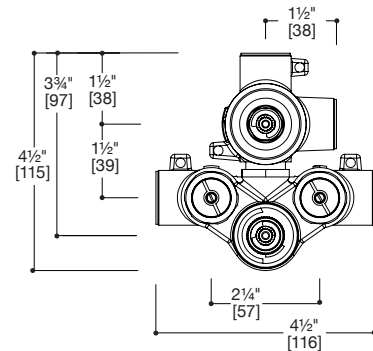

*Approximate measurements for comparison only.
Note: These dimensions and specifications are subject to change without notice.