

TA500R SPECIFICATIONS

ceiling-mount shower arm

FEATURES:

- Clean, elegant design
- Solid brass arm
- 19¾" projection from ceiling
- 1¼" arm diameter, 4" round trim
- Coordinating round shower heads available to compliment the pure·2 series

SPECIFICATIONS:

Warranty: Lifetime Limited Warranty (Residential)
One Year Warranty (Commercial)

Material: Brass

Connection: ½" NPT connection

Shipping Weight: 2.9lbs (1.32kg)

Shipping dimensions: 24" x 9½" x 4"
(610mm x 240mm x 100mm)

FINISHES:

- Polished Chrome
- Satin (-S)

INSTALLATION:

Install this product according to the installation guide. Our products must be installed by certified professionals only and according to our installation guide as well as federal, provincial / state and local building codes and regulations.

CODES / STANDARDS APPLICABLE:

- Meets or exceeds ANSI / ASME standard A112.18.1 and CAN / CSA B125.1-05 requirements
- ASME A112.19.2
- IAPMO / UPC / cUPC

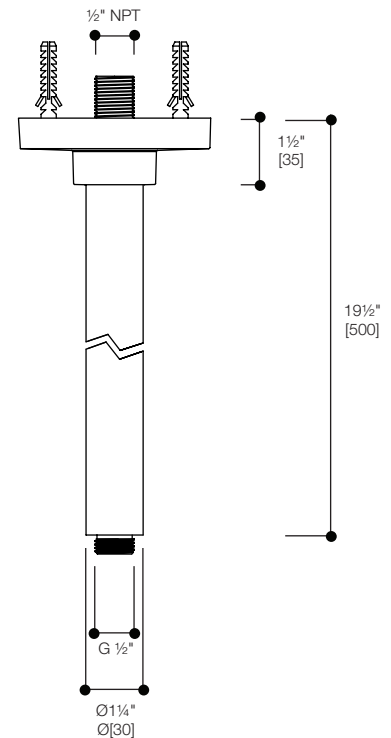
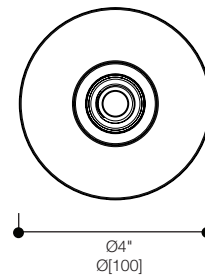

*Approximate measurements for comparison only.
Note: These dimensions and specifications are subject to change without notice.