

# TA300R SPECIFICATIONS

## ceiling-mount shower arm

### FEATURES:

- Clean, elegant design
- Solid brass arm
- 11¾" projection from ceiling
- 1¼" arm diameter, 4" round trim
- Coordinating round shower heads available to compliment the pure:2 series

### SPECIFICATIONS:

Warranty:	Lifetime Limited Warranty (Residential) One Year Warranty (Commercial)
Material:	Brass
Connection:	½" NPT connection
Shipping Weight:	2.5lbs (1.12kg)
Shipping dimensions:	24" x 9½" x 4" (610mm x 240mm x 100mm)

### FINISHES:

- Polished Chrome
- Satin (-S)

### INSTALLATION:

Install this product according to the installation guide. Our products must be installed by certified professionals only and according to our installation guide as well as federal, provincial / state and local building codes and regulations.

### CODES / STANDARDS APPLICABLE:

- Meets or exceeds ANSI / ASME standard A112.18.1 and CAN / CSA B125.1-05 requirements
- ASME A112.19.2
- IAPMO / UPC / cUPC

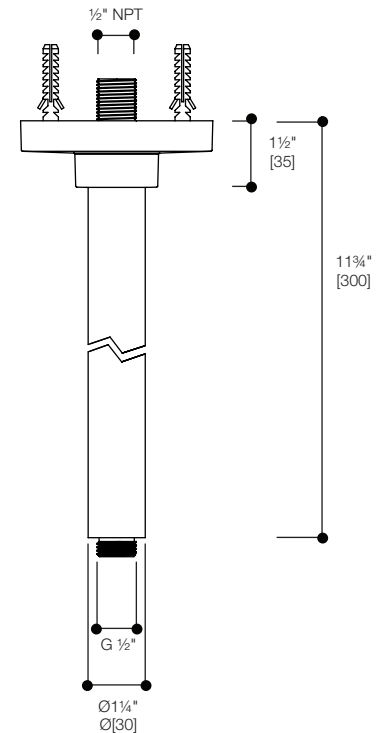
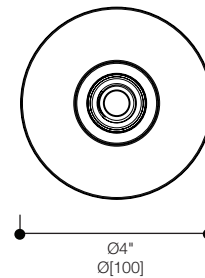

\*Approximate measurements for comparison only.  
Note: These dimensions and specifications are subject to change without notice.