

F51M1-1400 SPECIFICATIONS

51 collection series 1400 box mirror with LED lighting

FEATURES:

- Double box perimeter frame mirror with four vertical LED lights + two infrared switches
- 110V strip LED 9.6W/MT RV4200K
- Frame serves as two integral shelves
- Integral channel on the back for ease of installation: allows installer to adjust brackets to hit studs accordingly
- Made of IDROLEB ECOLOGICAL PANEL with the lowest formaldehyde emissions in the world
- IDROLEB also ensures defence against humidity
- Italian-crafted for superior quality

SPECIFICATIONS:

Dimensions:	(WHD) 55" x 25¼" x 5" (1400mm x 643mm x 125mm)*
Weight:	37.4lbs (17kg)*
Materials:	White Lacquer: MDF
Warranty:	Five Year Limited Warranty (Residential) One Year Warranty (Commercial)
Shipping Weight:	46.2lbs (21kg)*
Shipping Dimensions	(WHD) 29½" x 27¼" x 7" (x2) (750mm x 690mm x 175mm)* (x2)

STOCKED COLOR/FINISH:

Lacquer

01M
White
Matte

INSTALLATION NOTES:

Install this product according to the installation guide. Our products must be installed by professionals only and according to our installation guide as well as federal, provincial / state and local building codes and regulations.

CODES:

- Meets or exceeds UL/ULC, and CSA requirements
- CSA 22.2
- UL/ULC 962
- UL/ULC 8750

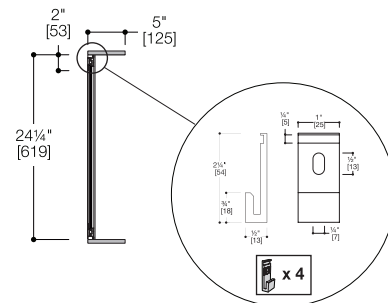
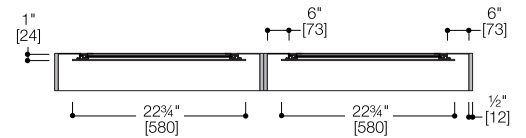
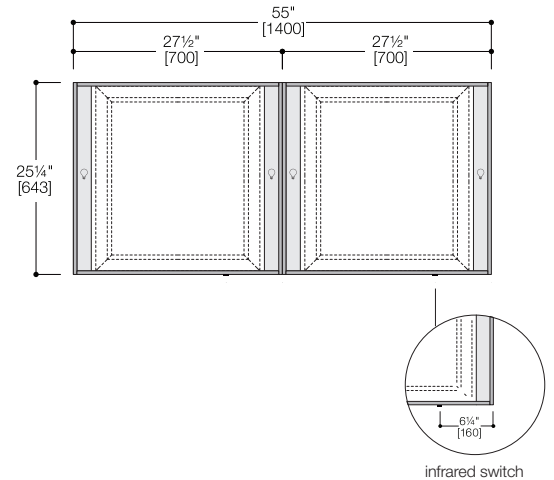

*Approximate measurements for comparison only.
Note: These dimensions and specifications are subject to change without notice.