

# Deck Mounted Basin Mixer

## Installation Guide

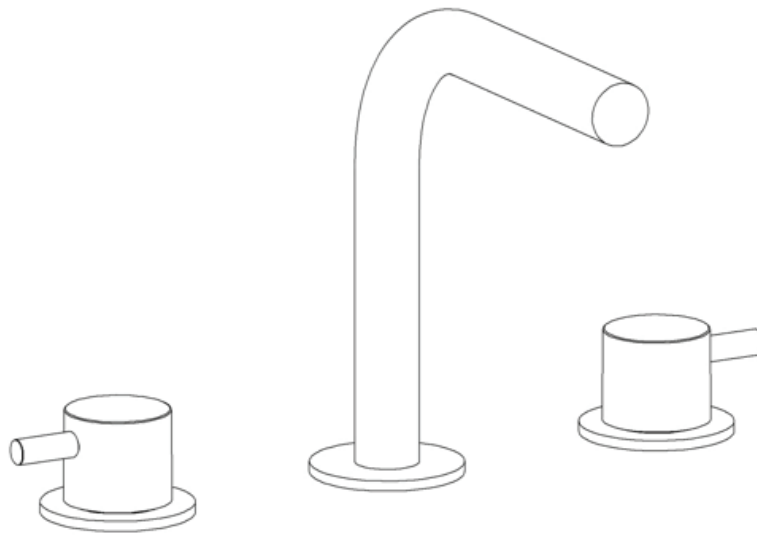

TSP141

## Attention — Before Installation

Thank you for choosing from among Blu's quality line of products. We recommend that you carefully read this installation guide to ensure your bathtub's proper operation and reliability for many years to come.

NOTE: Product is already optimized/preset for best drawing fitting - only minor adjustments may be needed. Adhere to all local building and plumbing codes. The diagrams in this guide are not construction plans. They are visual aids.

1. Inspect this product to ensure you have all parts as shown that are required for proper installation.
2. The valve cartridge has been factory tested and adjusted – DO NOT TAKE THE CARTRIDGE APART. Taking the cartridge apart will void the warranty.
3. Ensure that both hot and cold water feeds are properly connected to the marked lav connecting.
4. This product must be installed by a professional contractor.
5. Refer to the specification and assembly drawings attached for installation directions.
6. Flow Pressure –Min. 25 PSI, Max. 80 PSI. Recommended pressure – 50 to 60 PSI.

## Installation Requirements

Please read the instructions carefully so as to avoid any damage to the fixture.

1. To ensure this product is installed properly, you must read and follow these guidelines.
2. The owner/user of the faucet must keep this information for future reference.
3. Be sure your installation conforms to local codes.
4. Refer to the specification and assembly drawings attached. Faucet is sold partially assembled but shown fully disassembled for illustrative and service purposes only.
5. Inspect this product to ensure you have all parts required for proper installation.
6. Use only a strap wrench or protected/smooth-jaw wrench on any finished surface.
7. If possible, install the faucet assembly on the sink or mounting surface before setting.
8. Do NOT use putty during this installation.

### CLEANERS FOR FITTINGS AND ACCESSORIES

To avoid damaging the surface and working components of the fittings, certain precautions must be taken in terms of usage and subsequent cleaning as many cleaning agents contain acids for general cleaning and removing calcium deposits. When caring for your fittings and accessories, please note the following:

- Only apply cleaners which are expressly intended for the use
- Never use any cleaner containing hydrochloric acid, formic acid or acetic acid on or near the fitting, as they can cause considerable damage
- Do not use cleaners containing phosphoric acid
- Do not use cleaners containing chlorine bleach solutions
- Never mix or combine cleaning agents
- Abrasive cleaners and unsuitable scouring agents such as scouring pads

## Technical Support Assistance

If further assistance is required, please contact:

Product Support at 1.866.907.0122 (09:00 – 17:00hrs PST) or email [technical@blubathworks.com](mailto:technical@blubathworks.com)

### North America

Blu Bathworks Inc.

188 Smithe Street, Vancouver, BC, Canada, V6B 6A9

T +1.604.299.0122 F +1.604.299.0125

## INSTALLATION STEP 1

- Before installation drill three holes,  $\varnothing 27\text{mm} / \varnothing 1''$  for the spout and  $\varnothing 32\text{mm} / \varnothing 1\frac{1}{4}''$  for the two lateral stop valves.
- Screw the nuts (1) on the threaded rod and the lateral stop valves (2).
- Place the metal rings (3).
- The lateral stop valve with color BLUE is on the right and RED on the left.

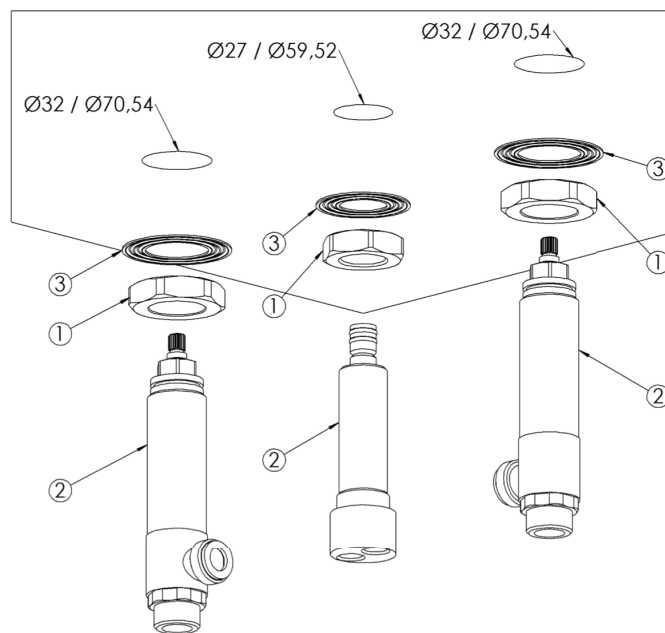

## INSTALLATION STEP 2

- Position the O-rings (2) in its site on the nuts (1).
- Screw the nuts (1), as per drawing (A), on the threaded rods.
- Once the correct position of the rings is reached, tighten the nuts located under the wash basin mixer to fix the threaded rods.

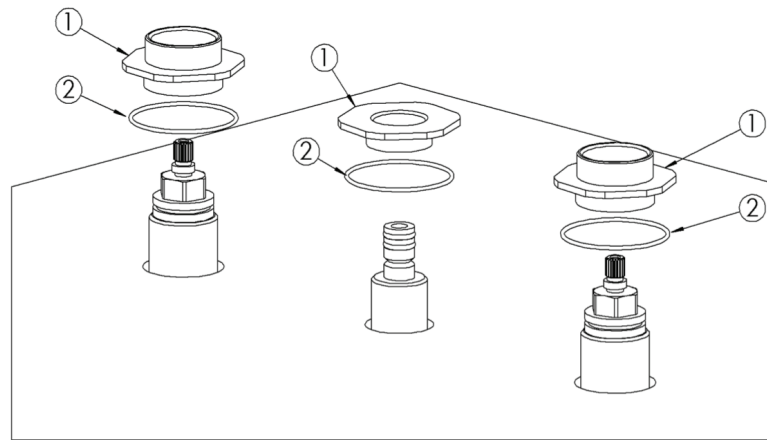

- (A)

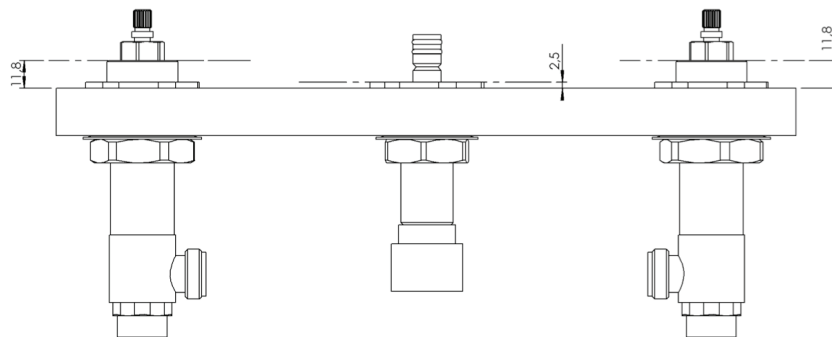

### INSTALLATION STEP 3

- Place the three small cover plates (1).
- Place the O-rings (2) and screw the cap (3) to secure the cover plates.

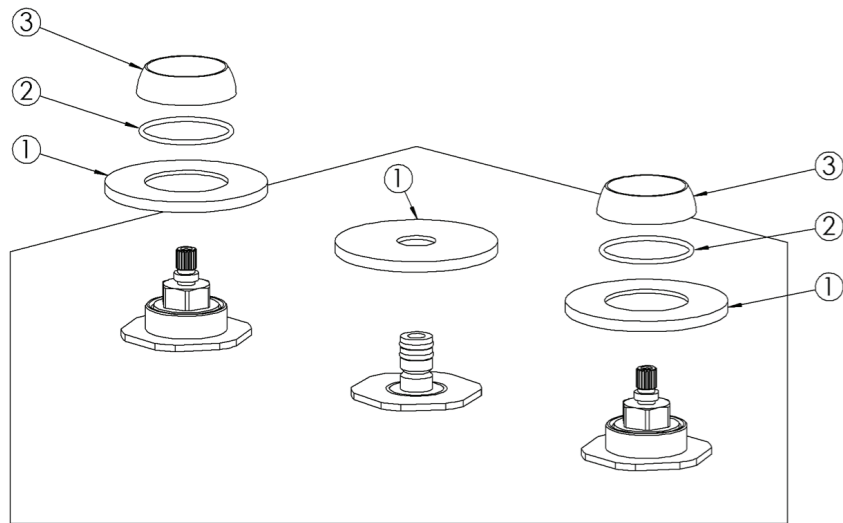

#### INSTALLATION STEP 4

- Place the centering insert (1) and fix it with the screw (2).
- Place the control handle (3) and fix the grub screws (4).
- Screw the lever (5).
- Place the O-ring (6) and the spout (7).
- Fix the spout with the grub screw (8).

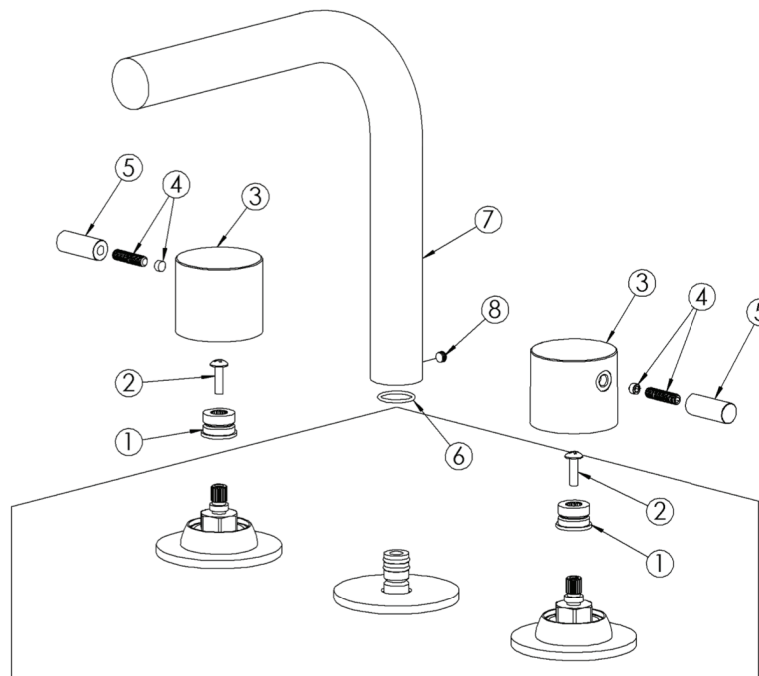



# TSP141

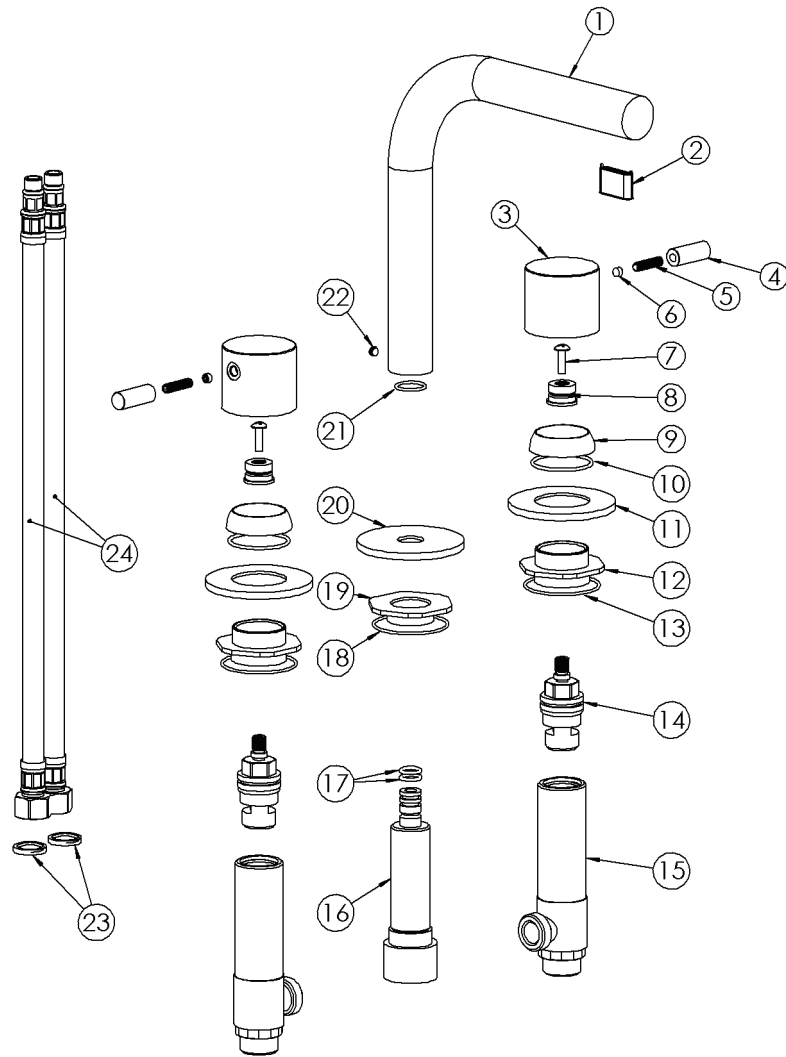



# warranty

## LIMITED FURNITURE RESIDENTIAL WARRANTY

Blu Bathworks® ("Blu") furniture products are warranted to the original purchaser to be free from defects in all material and workmanship during normal residential use for a period of five (5) years from the date of purchase. Blu will, at its election, repair, provide a replacement part or product, or make appropriate adjustment, subject to the terms and conditions set forth in this warranty.

## LIMITED CERAMICS RESIDENTIAL WARRANTY

Blu Bathworks® ("Blu") ceramic products are warranted to the original purchaser to be free from defects in all material and workmanship during normal residential use for a period of one (1) year from the date of purchase. Blu will, at its election, repair, provide a replacement part or product, or make appropriate adjustment, subject to the terms and conditions set forth in this warranty.

## LIMITED blu-stone™ RESIDENTIAL WARRANTY

Blu Bathworks® ("Blu") blu-stone™ products are warranted to the original purchaser to be free from defects in all material and workmanship during normal residential use for a period of five (5) years from the date of purchase. Blu will, at its election, repair, provide a replacement part or product, or make appropriate adjustment, subject to the terms and conditions set forth in this warranty. Blu Bathworks® does not recommend exceeding US/Canada maximum hot water temperature regulations of 150°F/65°C, respectively. Exceeding stated temperatures could result in damage to blu.stone basins and bathtubs.

## LIMITED ACRYLIC BATHTUBS RESIDENTIAL WARRANTY

Blu Bathworks® ("Blu") acrylic bathtubs are warranted to the original purchaser to be free from defects in all material and workmanship during normal residential use for a period of five (5) years from the date of purchase. Blu will, at its election, repair, provide a replacement part or product, or make appropriate adjustment, subject to the terms and conditions set forth in this warranty.

## LIMITED TAPWARE RESIDENTIAL WARRANTY

Blu Bathworks® ("Blu") tapware products are warranted to the original purchaser to be free from defects in all mechanical parts and polished chrome finishes during normal residential use for as long as the original purchaser owns his or her home. Blu will, at its election, repair, provide a replacement part or product, or make appropriate adjustment, subject to the terms and conditions set forth in this warranty.

## LIMITED ELECTRONICA TAPWARE RESIDENTIAL WARRANTY

Blu Bathworks® ("Blu") electronica tapware products are warranted to the original purchaser to be free from defects in all electronic parts during normal residential use for a period of five (5) years from the date of purchase. Blu will, at its election, repair, provide a replacement part or product, or make appropriate adjustment, subject to the terms and conditions set forth in this warranty.

## LIMITED COMMERCIAL WARRANTY

Blu Bathworks® ("Blu") products are warranted to the original purchaser to be free from defects in all material and workmanship during normal usage for a period of one (1) year from the date of purchase. Blu will, at its election, repair, provide a replacement part or product, or make appropriate adjustment, subject to the terms and conditions set forth in this warranty.

# terms and conditions

This warranty applies only to Blu Bathworks® ("Blu") products distributed in North America.

This warranty is non-transferable and is for the exclusive benefit of the original purchaser of a Blu product. This warranty may be exercised by the original purchaser of a unit in a new residential development. Blu recommends using a professional plumber for all installation and repair. This warranty does not apply to products that have been installed in any manner other than as set out in Blu's printed instructions, or to products that have been altered in any way.

For further clarity, the above stated warranty does not cover or apply to damage attributable to:

- (a) neglect, misuse, abuse, accident or negligence;
- (b) normal wear and tear;
- (c) dirt or lime scale, or the use of inappropriate cleaners (such as those containing abrasives, ammonia, acids, waxes, bleaches, solvents, alcohol, or any product not recommended for chrome); and
- (d) damage caused by transportation, or improper storage.

This is the only warranty of Blu, which makes no other warranty of any kind. Blu disclaims any liability for special, incidental or consequential damages. In no event shall the liability of Blu under this warranty exceed the purchase price of the product.

## PROCEDURE FOR WARRANTY SERVICE

Refer to [blubathworks.com](http://blubathworks.com) for policy and procedures relating to requests for service under the terms of this warranty.

Original proof of purchase is required. Blu is not responsible for removal or installation costs, or the costs of shipping and handling associated with any service. Repaired or replaced products or parts are warranted only for the period remaining under the initial warranty.