

DUO·2 two outlet electronica thermostatic control mixer

Installation Guide

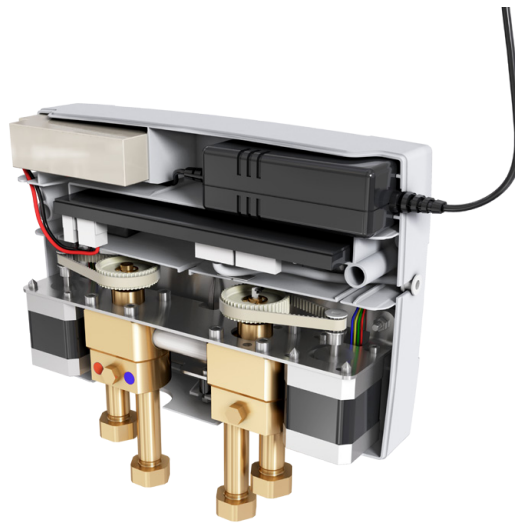

TEE030S

Step 1 - connecting the control mixer for shower & bathtub installation

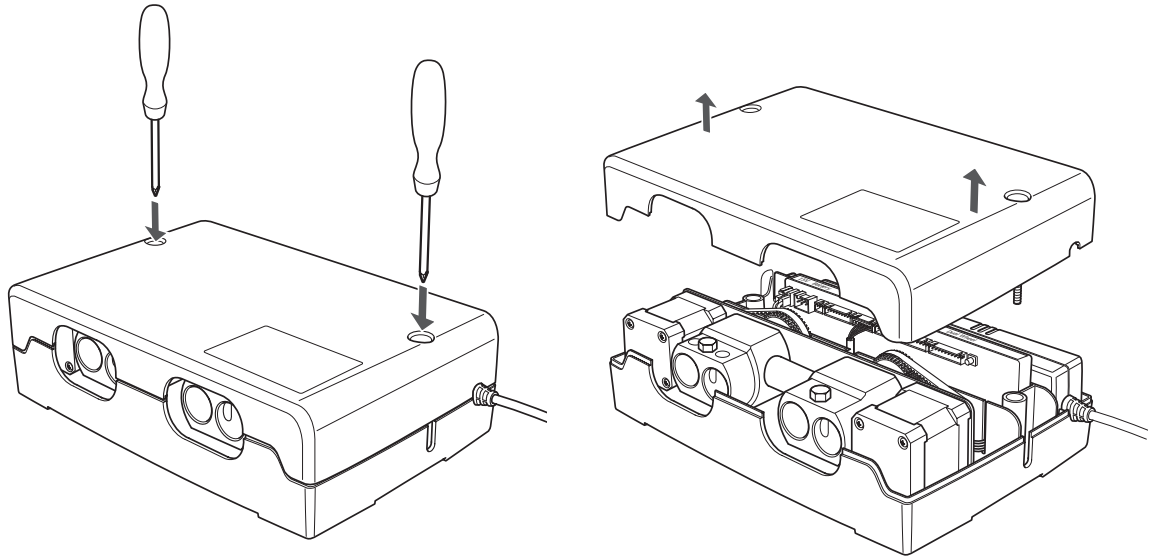

Remove the control mixer cover.

Important: The control mixer must be installed in a dry area that is accessible for future maintenance

Step 2 - components of two outlet thermostatic mixer

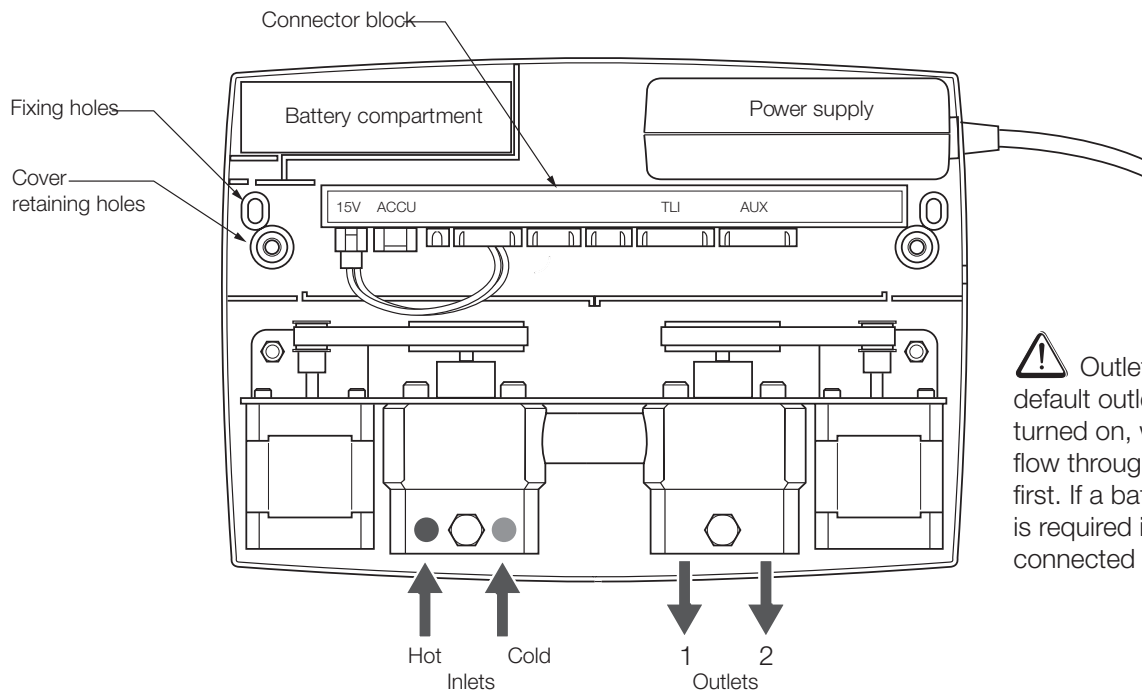

! Outlet #1 is the default outlet, when turned on, water will flow through this outlet first. If a bath filler option is required it must be connected to outlet 1.

Step 3

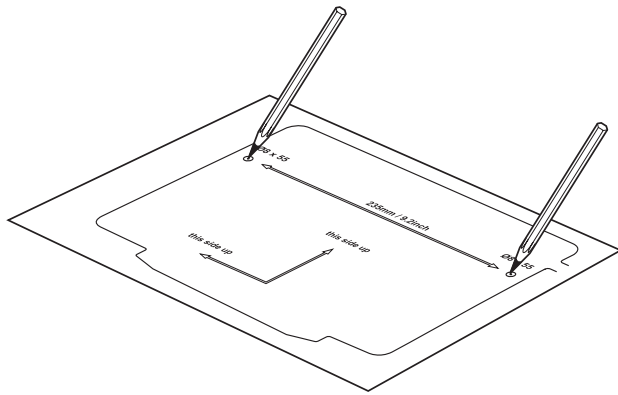

If required, use the supplied template to mark the position of the control mixer fixing holes in the selected location.

Step 4

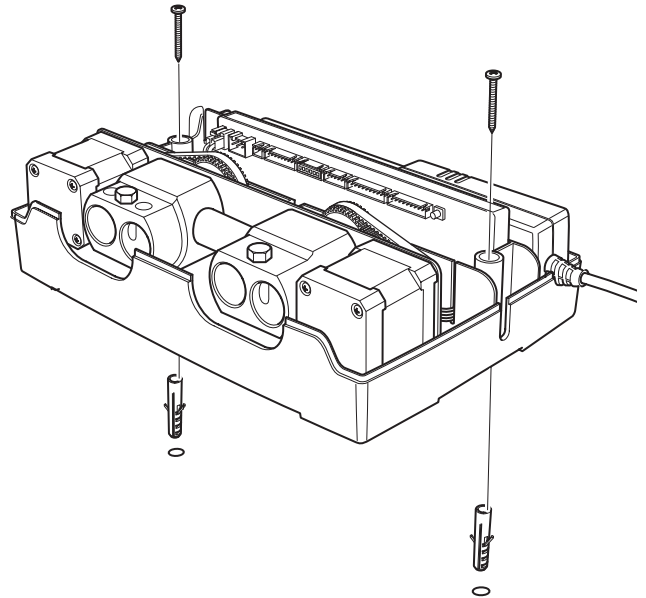

Fix the control box in position using the screw kit supplied.

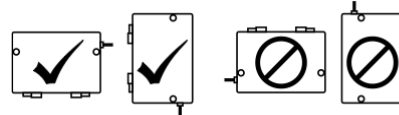

Step 5

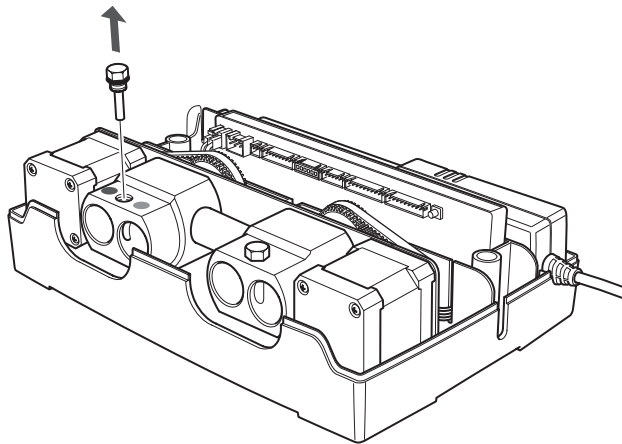

Remove the inlet connectors' retaining bolt.

Step 6

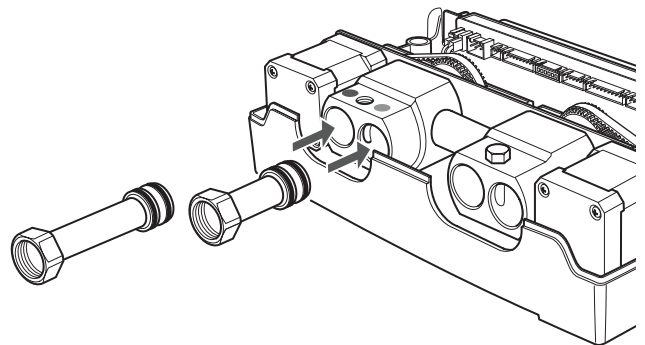

Fully insert the inlet connectors into the inlet valves (one long and one short connector).

! If required, the 'nut' ends of the inlet connectors (and outlet connectors) can be cut off and compression fittings can be used to attach the pipework.

Step 7

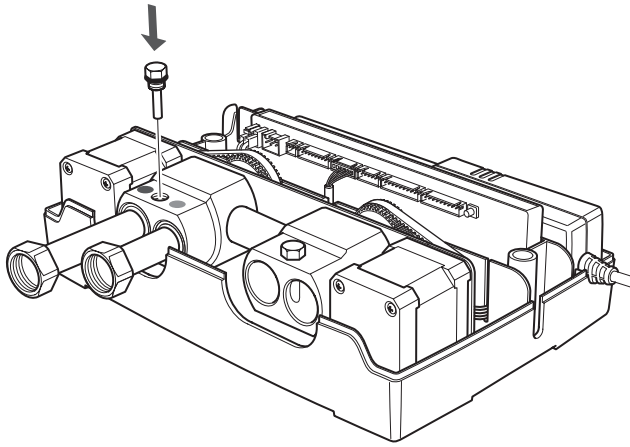

Re-insert the inlet connectors retaining bolt.

Step 8

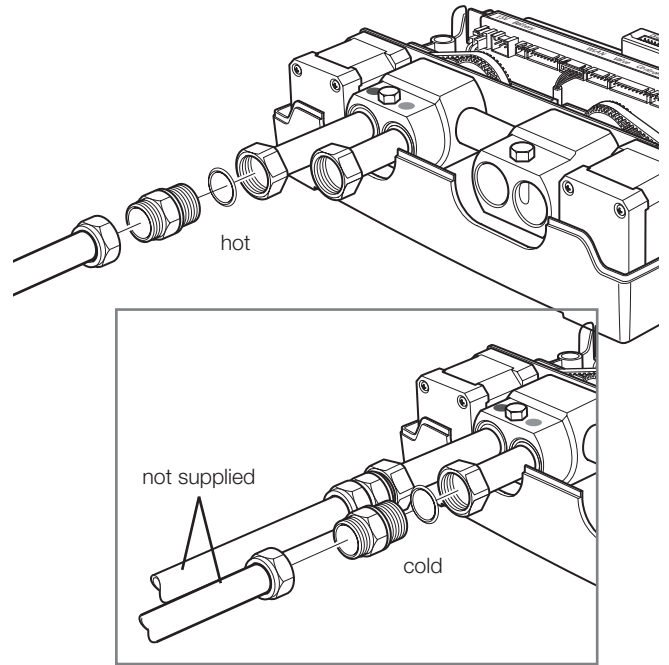

Important: Flush through the pipework before connection.

Filter screen for inlet is highly recommended.
Attach the NPT adaptors to the hot & cold water supply connections.

Step 9

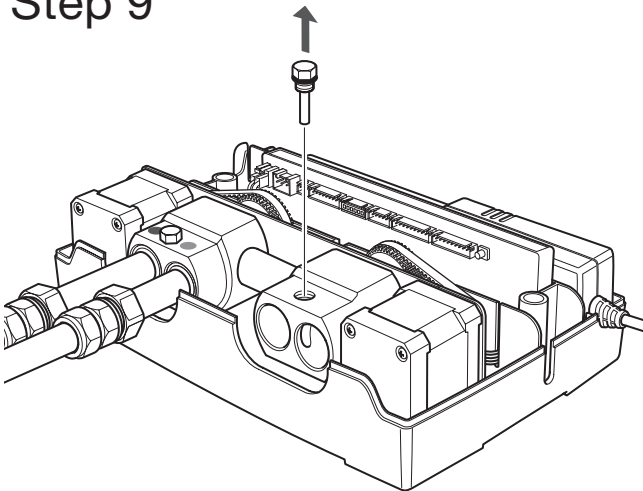

Remove the outlet connectors' retaining bolt.

Step 10

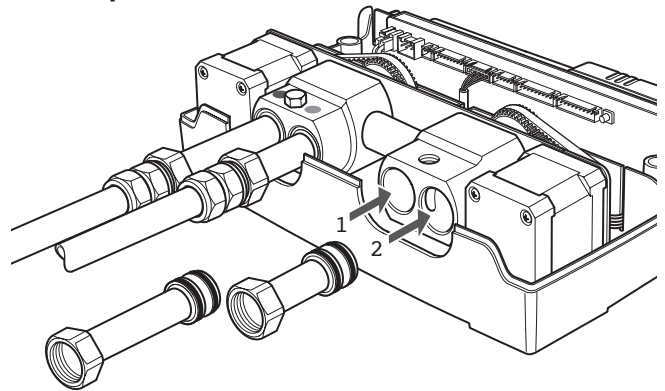

Fully insert the outlet connectors into the outlet valves (one long and one short connector).

⚠ Note: Outlet 1 is the default outlet. When turned on, water will flow through this outlet first. If a bath filler option is required, it must be connected to Outlet 1.

Step 11

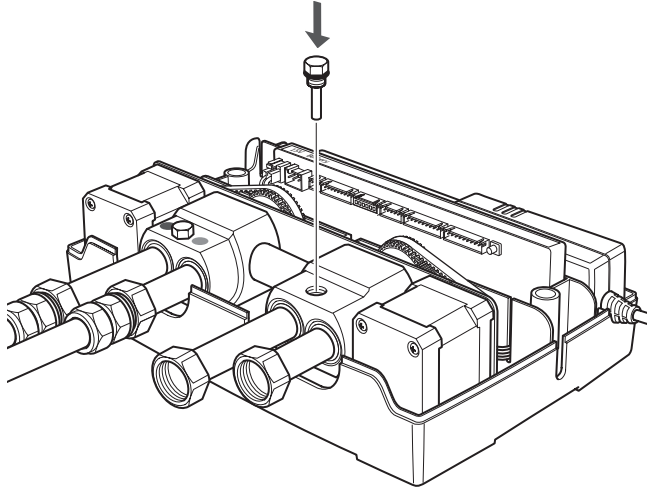

Re-insert the outlet connectors retaining bolt.

Step 12

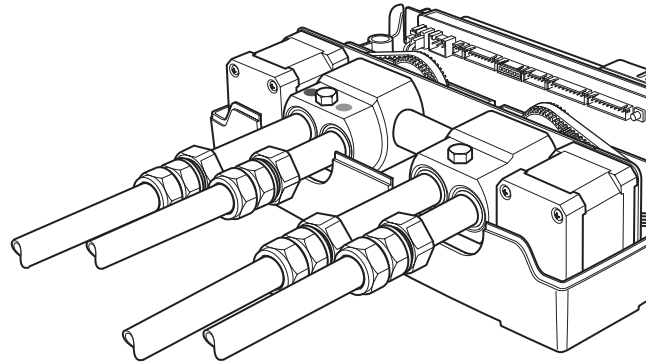

Attach the supplied NPT adaptor pipework to the outlet connectors.
Make a note of which pipe goes to which outlet.

Note: Make sure that the pipework is perpendicular to the control box so that there is no strain on the fittings, use pipe clips as required.

Run a pipe from the mixed water outlet on the control box through the wall to the proposed position of the shower hose outlet etc.

Step 13

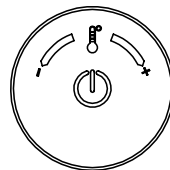
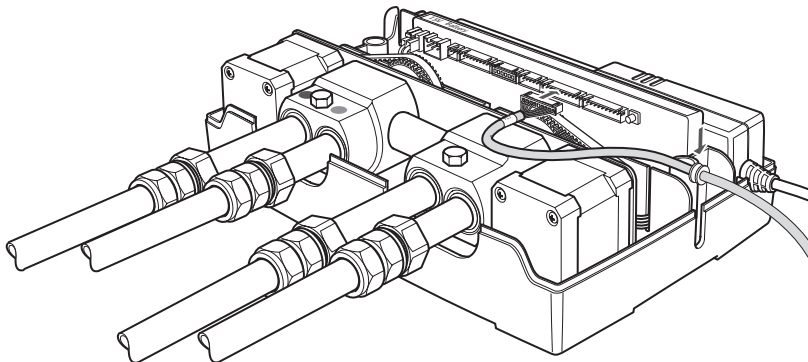

Connect the data cable from the on-off/temperature control to the 'TLI' port in the control box.

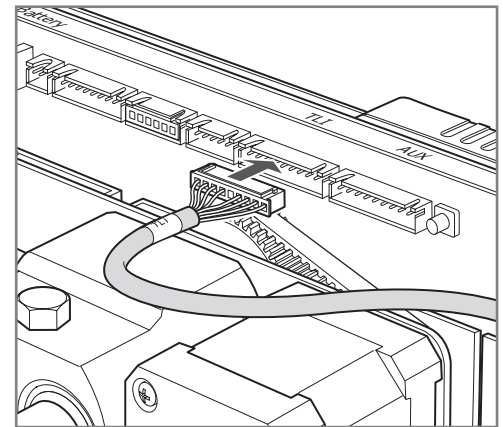

Step 14 - connect flow/outlet control data cable

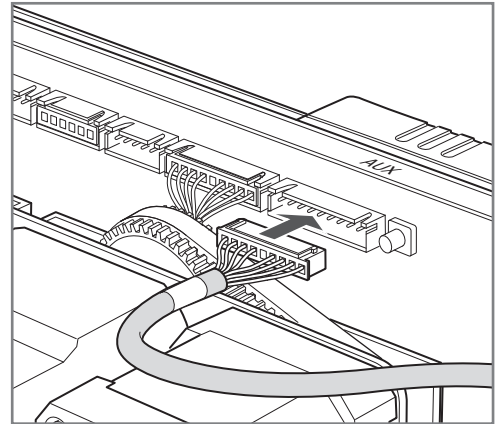
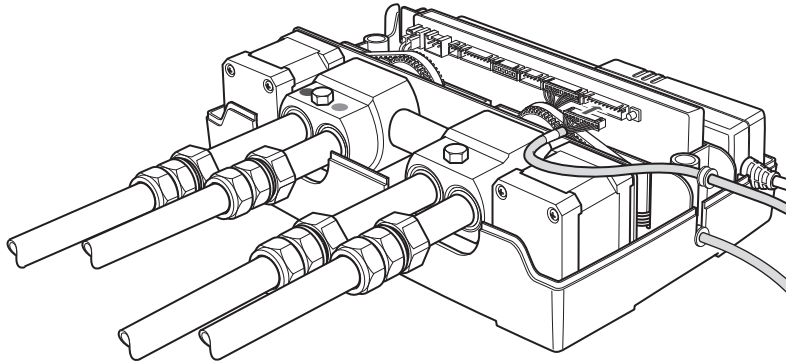

Connect the data cable from the flow volume/divertor control to the “dual wheel” connection in the “AUX” port in the control box.

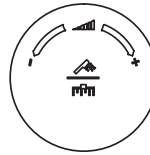

Step 15 - connect the back-up battery

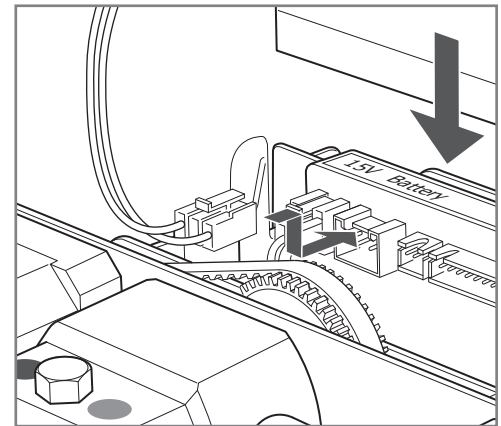
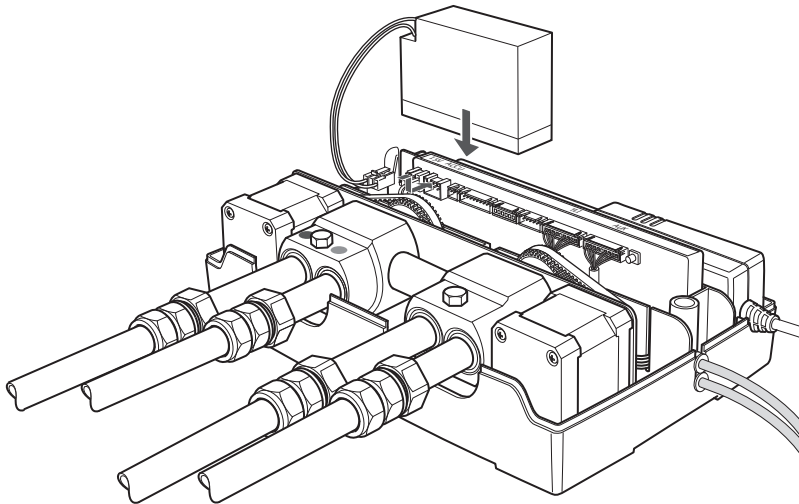

Connect the battery cable to the “Battery for battery back-up” connection and place the battery in the compartment.

Step 16

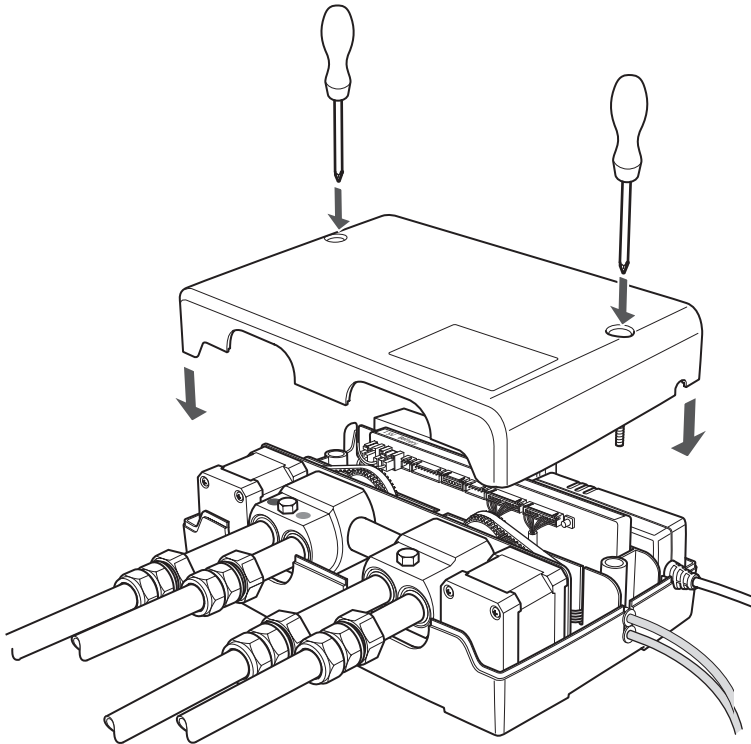

Refit the control box cover.

Step 17



Connect an all-pole mains switch in the electrical installation in accordance with the current wiring regulations.



Note:

- the electrical installation and testing must be carried out by a qualified electrician
- Electrical connections and the minimum distances between water and electricity connections must be installed or laid out in accordance with the valid national regulations.
- Equipment for protection against faulty currents must be installed (residual current circuit breaker), N=30mA
- All work on the electronic components must be only carried out under absence of voltage

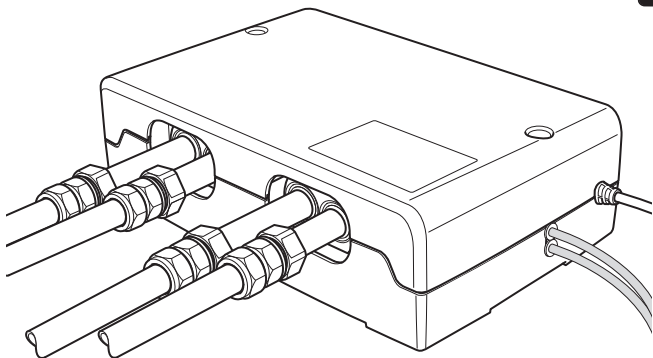

Note: Damages to the faucet resulting from incorrect handling and installation are not covered in the manufacturer's warranty.

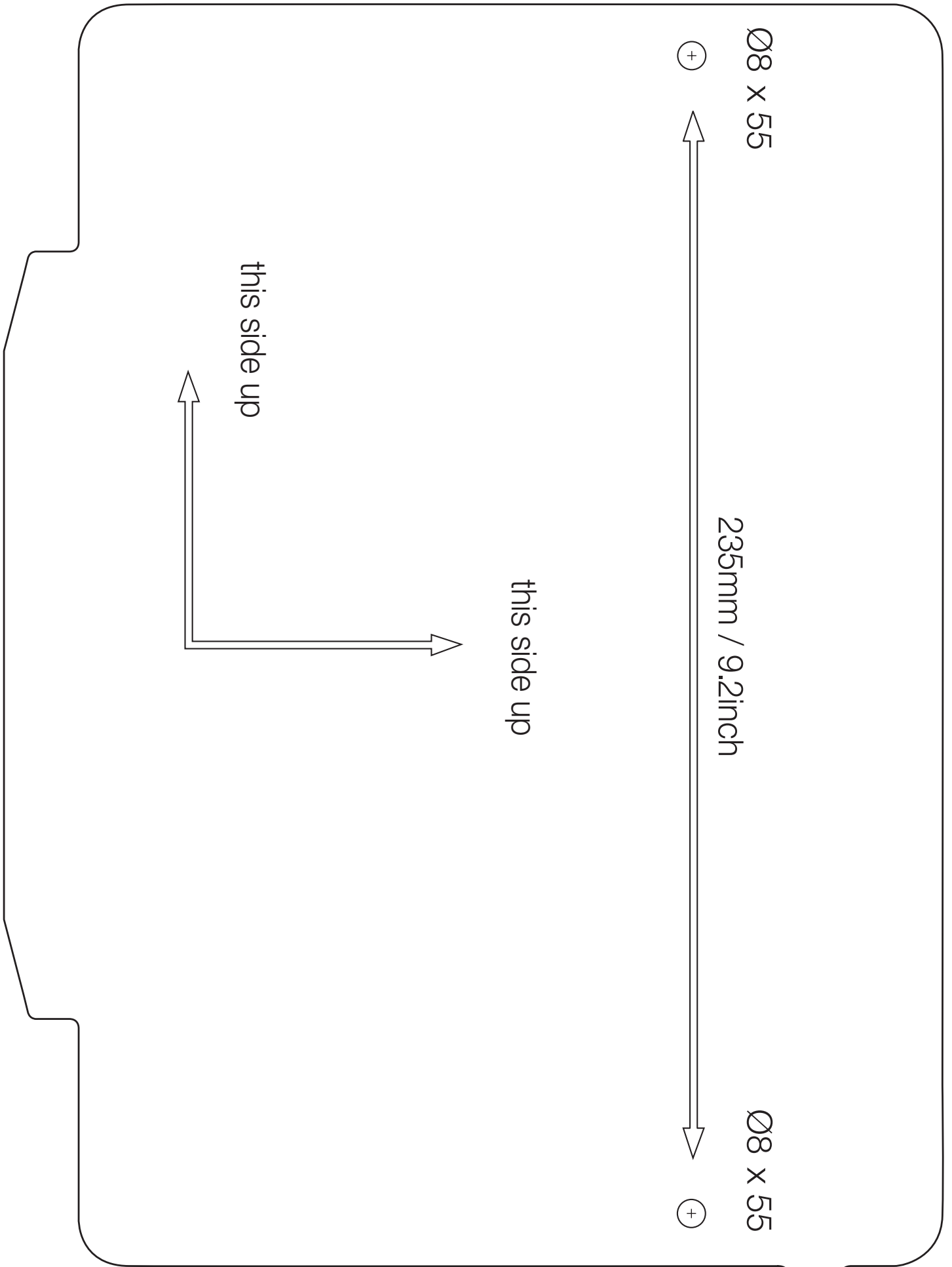

Note: Diagram is to scale. Ensure when printing that image size is at 100%.

warranty

LIMITED FURNITURE RESIDENTIAL WARRANTY

Blu Bathworks® ("Blu") furniture products are warranted to the original purchaser to be free from defects in all material and workmanship during normal residential use for a period of five (5) years from the date of purchase. Blu will, at its election, repair, provide a replacement part or product, or make appropriate adjustment, subject to the terms and conditions set forth in this warranty.

LIMITED CERAMICS RESIDENTIAL WARRANTY

Blu Bathworks® ("Blu") ceramic products are warranted to the original purchaser to be free from defects in all material and workmanship during normal residential use for a period of one (1) year from the date of purchase. Blu will, at its election, repair, provide a replacement part or product, or make appropriate adjustment, subject to the terms and conditions set forth in this warranty.

LIMITED blu-stone™ RESIDENTIAL WARRANTY

Blu Bathworks® ("Blu") blu-stone™ products are warranted to the original purchaser to be free from defects in all material and workmanship during normal residential use for a period of five (5) years from the date of purchase. Blu will, at its election, repair, provide a replacement part or product, or make appropriate adjustment, subject to the terms and conditions set forth in this warranty. Blu Bathworks® does not recommend exceeding US/Canada maximum hot water temperature regulations of 150°F/65°C, respectively. Exceeding stated temperatures could result in damage to blu.stone basins and bathtubs.

LIMITED ACRYLIC BATHTUBS RESIDENTIAL WARRANTY

Blu Bathworks® ("Blu") acrylic bathtubs are warranted to the original purchaser to be free from defects in all material and workmanship during normal residential use for a period of five (5) years from the date of purchase. Blu will, at its election, repair, provide a replacement part or product, or make appropriate adjustment, subject to the terms and conditions set forth in this warranty.

LIMITED TAPWARE RESIDENTIAL WARRANTY

Blu Bathworks® ("Blu") tapware products are warranted to the original purchaser to be free from defects in all mechanical parts and polished chrome finishes during normal residential use for as long as the original purchaser owns his or her home. Blu will, at its election, repair, provide a replacement part or product, or make appropriate adjustment, subject to the terms and conditions set forth in this warranty.

LIMITED ELECTRONICA TAPWARE RESIDENTIAL WARRANTY

Blu Bathworks® ("Blu") electronica tapware products are warranted to the original purchaser to be free from defects in all electronic parts during normal residential use for a period of five (5) years from the date of purchase. Blu will, at its election, repair, provide a replacement part or product, or make appropriate adjustment, subject to the terms and conditions set forth in this warranty.

LIMITED COMMERCIAL WARRANTY

Blu Bathworks® ("Blu") products are warranted to the original purchaser to be free from defects in all material and workmanship during normal usage for a period of one (1) year from the date of purchase. Blu will, at its election, repair, provide a replacement part or product, or make appropriate adjustment, subject to the terms and conditions set forth in this warranty.

terms and conditions

This warranty applies only to Blu Bathworks® ("Blu") products distributed in North America.

This warranty is non-transferable and is for the exclusive benefit of the original purchaser of a Blu product. This warranty may be exercised by the original purchaser of a unit in a new residential development. Blu recommends using a professional plumber for all installation and repair. This warranty does not apply to products that have been installed in any manner other than as set out in Blu's printed instructions, or to products that have been altered in any way.

For further clarity, the above stated warranty does not cover or apply to damage attributable to:

- (a) neglect, misuse, abuse, accident or negligence;
- (b) normal wear and tear;
- (c) dirt or lime scale, or the use of inappropriate cleaners (such as those containing abrasives, ammonia, acids, waxes, bleaches, solvents, alcohol, or any product not recommended for chrome); and
- (d) damage caused by transportation, or improper storage.

This is the only warranty of Blu, which makes no other warranty of any kind. Blu disclaims any liability for special, incidental or consequential damages. In no event shall the liability of Blu under this warranty exceed the purchase price of the product.

PROCEDURE FOR WARRANTY SERVICE

Refer to blubathworks.com for policy and procedures relating to requests for service under the terms of this warranty.

Original proof of purchase is required. Blu is not responsible for removal or installation costs, or the costs of shipping and handling associated with any service. Repaired or replaced products or parts are warranted only for the period remaining under the initial warranty.