

**MONIQUE  
69" ACRYLIC DOUBLE  
SLIPPER TUB**

Cat. No.  
ATDSN69R



L: 69"  
W: 28-1/2"  
H: 30-3/4"

Water depth: 17-3/4" to top of tub  
Water depth: 13-1/4" to overflow

**The following is recommended for ATDSN69R tubs:**

- Faucets: part #4602, 4022 or 4025
- Rigid, freestanding supplies: part #4502
- Leg tub drain: part #5599LT or 5599TS

Gallon Capacity without OF: 53  
Gallon Capacity with OF: 43  
Shipping Weight: 296 lbs.  
Empty Weight: 100 lbs.  
Filled Weight without OF: 543 lbs.  
Filled Weight with OF: 459 lbs.



Overflow can be drilled.  
With overflow drilled this tub requires drain 5599PD.  
**Tubs that have been drilled with overflow are "special order" and are not returnable.**

**Features:**

- ▶ Interior and exterior walls acrylic sheets
- ▶ Space between walls partially filled with fiberglass and resin
- ▶ No faucet holes
- ▶ No overflow
- ▶ Continuous rolled rim
- ▶ Cast Iron imperial feet available in 4 finishes
- ▶ Tub is thoroughly inspected before shipment
- ▶ IAPMO Certified

**Feet Finishes:**

- BN** Brushed Nickel
- CP** Polished Chrome
- PB** Polished Brass
- ORB** Oil Rubbed Bronze



**Custom Colors Available** (inside of tub is always white enamel):  
Painted bathtubs are considered "special order" and are not returnable  
\$160 Bisque or Black \$250 Designer Color

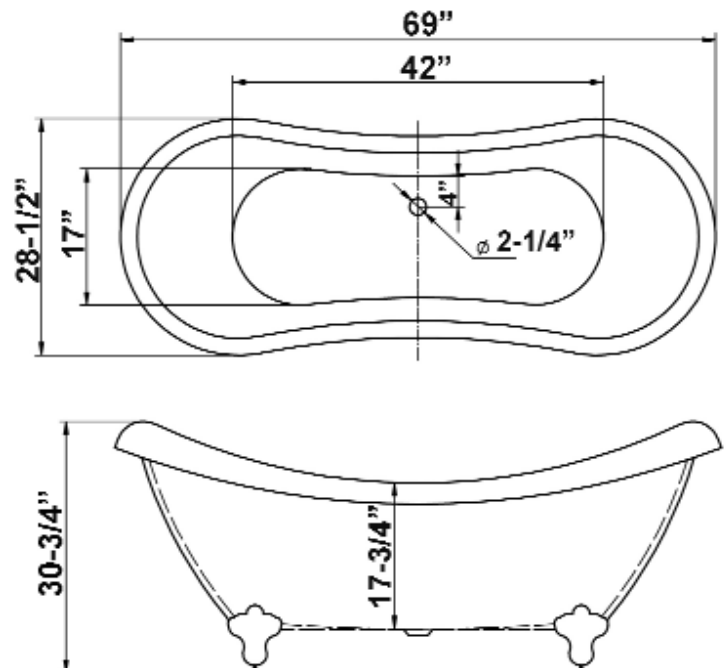

Dimensions of fixture are nominal and specifications subject to change without notice.