

**AXENT**  
SWITZERLAND

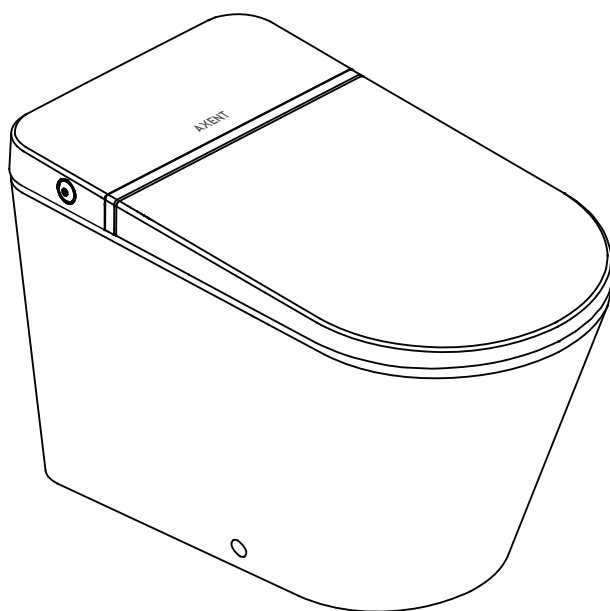

PRIMUS  
W431  
**INSTALLATION INSTRUCTION**  
&  
**USER MANUAL**



## **THANK YOU**

---

Thank you for selecting an AXENT Switzerland product. To ensure proper installation, please review these instructions carefully before use. Carefully unpack and examine the intelligent toilet before installation. For any questions, contact us at 1-800-769-4857. Thank you again for choosing AXENT.

## **BEFORE YOU BEGIN**

---

### **CAUTION!**

---

#### **Risk of personal injury or product damage.**

Handle with care. Vitreous china can break or chip if handled carelessly.

ALL INSTALLATION PROCEDURES SHOULD COMPLY WITH APPLICABLE LOCAL PLUMBING AND BUILDING CODES.

INSTALLATION BY A PROFESSIONAL, LICENSED PLUMBER OR CONTRACTOR IS HIGHLY RECOMMENDED.



## **SAFETY SYMBOLS**

---

The following warning signs warn you of dangerous situations and their severity:



**DANGER!**

High Risk, Lethal Hazards, Severe Injuries



**WARNING!**

Medium Risk, Severe Injuries



**CAUTION!**

Low Risk, Minor Injuries



**NOTE!**

Damage to Property

## **TARGET READERSHIP AND INSTALLER QUALIFICATIONS**

---

Installation must be carried out by qualified professionals.  
Repairs should only be performed by trained and qualified persons.



**NOTE!**

Follow all local installation regulations and country specific voltage and plumbing standards. DO NOT install the intelligent toilet in rooms where there is a danger of frost. The room temperature and water temperature must not be less than 4°C ( 39 °F ).

Condensation may form when the intelligent toilet is brought from a cold location to a warm one. Leave the unit switched off for a few hours before operating.



**DANGER!**

### **Risk of fatal electric shock**

---

The appliance must be grounded and plugged into a GFCI outlet.  
DO NOT remove individual components from (inside of) the intelligent toilet.  
If the unit has a damaged cord or plug, return the product to a service center for repair. The cord or plug may only be changed by qualified personnel.



**CAUTION!**

DO NOT reuse old hoses. Please use new hoses and included components.  
Axent Corp is not liable or responsible for damaged caused by 3rd party components

## **TECHNICAL SUPPORT**

---

For any questions or any assistance with this product, please contact your dealer or call us at  
1-800-769-4857  
support@axentproducts.com  
www.axentbath.us

## SCOPE OF DELIVERY

---

Standard delivery contents

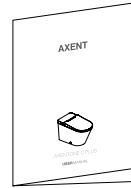
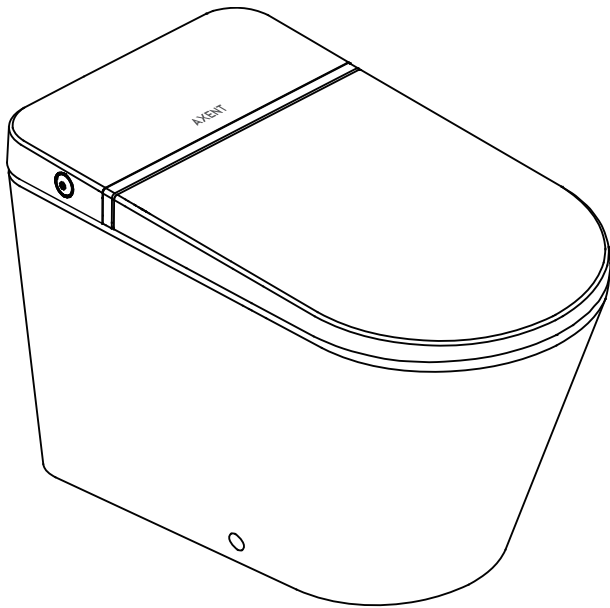

User Manual



Bowl Plug

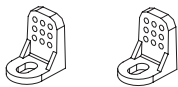

Fixed support



Bowl Mounting Hardware

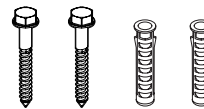

Fixed support  
Mounting Hardware

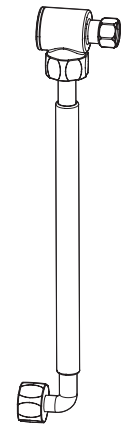

Inlet Hose and Filter  
(Filter Adapter Requires  
3/8" FIP Connection.)



The below parts are not included with the toilet.

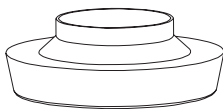

Base Flange

# INSTALLATION

# 1

## 1

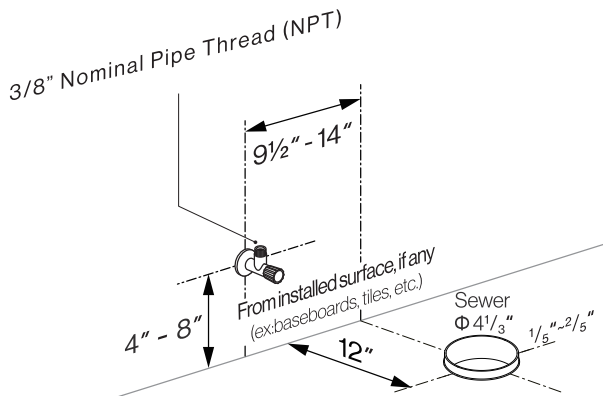

**!** Please verify these dimensions before beginning installation. These dimensions may vary in some locations. Recommended operating pressure 20 - 108 psi.

## 2

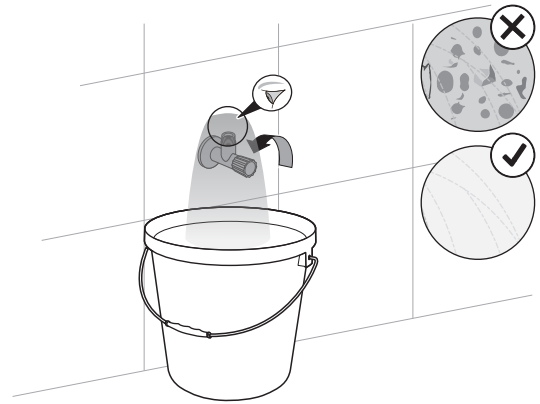

**!** Please run water until clear.

## 3

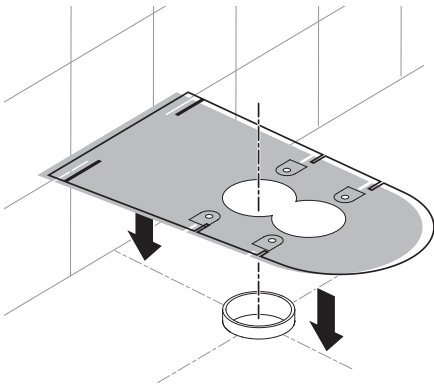

## 4

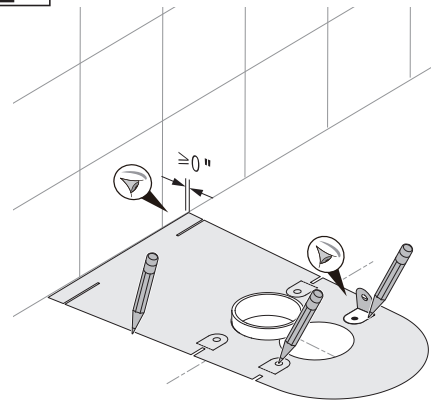

**!** To ensure the normal maintenance work, please make sure that the distance between the wall and the product meets the requirements.

## 5

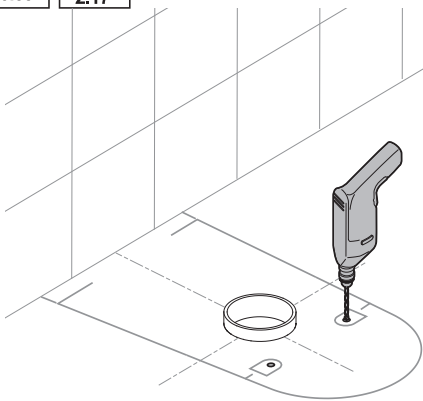
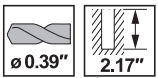

## 6

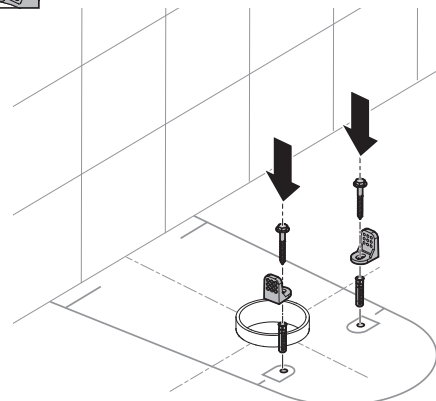

# INSTALLATION

7 

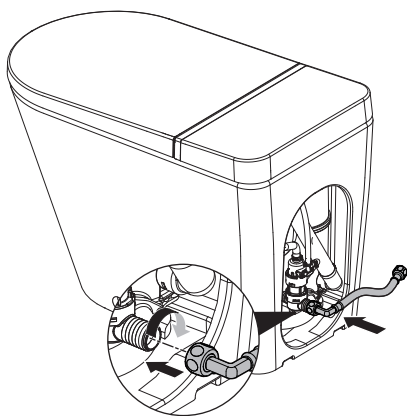

8

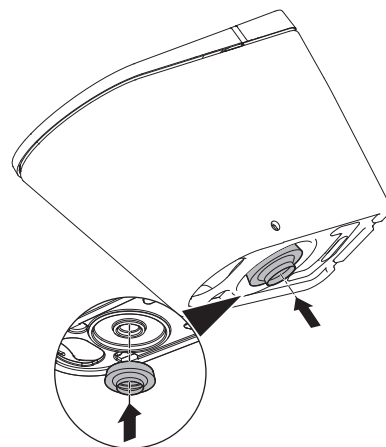

9

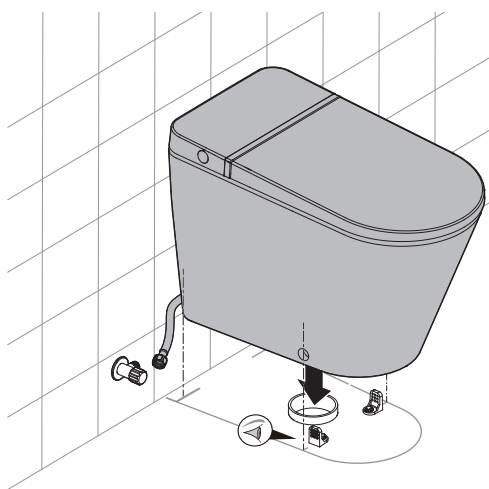

10 

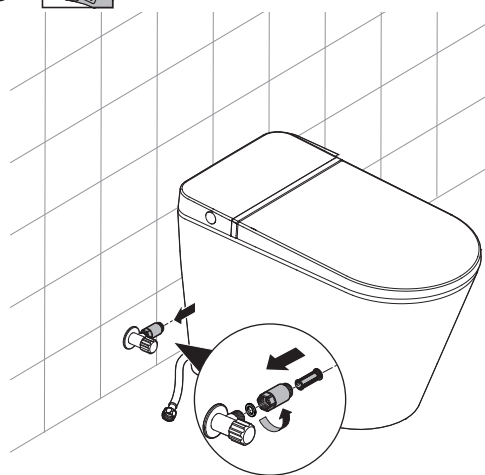

11 

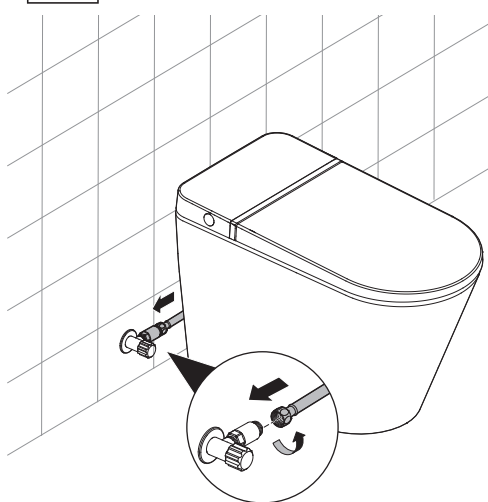

12

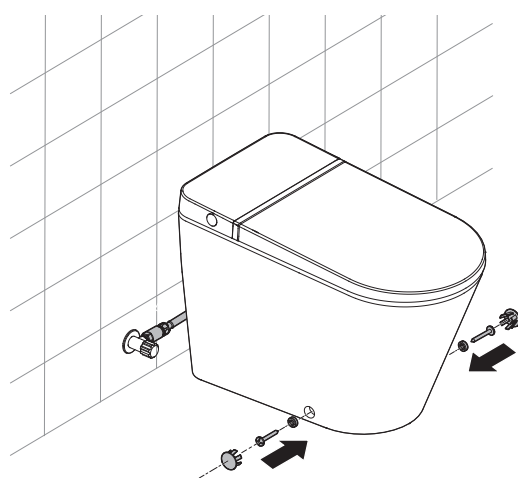

## OPERATION AND MAINTENANCE

---

### MANUAL FLUSH

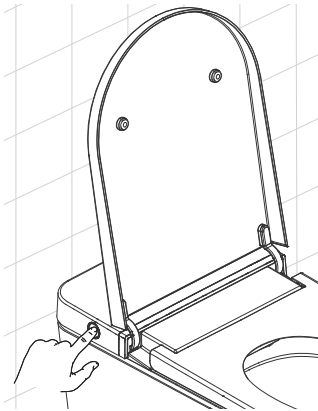

The manual flush button is on the left side as you stand facing the toilet.  
Hold for 1 full second to flush.

### DURING VACATION

If this product will not be in use for an extended period of time, please perform the following in this order:

- Shut off the water inlet valve.
- Press the Manual Flush button.

### WINTERIZATION

Please ensure water temperatures will not drop below 39 °F. Frost or frozen water will damage the system and may lead to leakage.

If the water or ambient temperature drops below 39 °F, please discontinue use of product. Additionally, if the intelligent toilet is moved from a cold location to a warm location, condensation may form. Leave the unit switched off for a few hours before use.

- Shut off the water inlet valve.
- Disconnect the water inlet hose from the filter to drain out the water inside of the line.
- Press the Manual Flush button.



FAILURE TO DRAIN SYSTEM MAY RESULT IN DAMAGE TO SYSTEM AND LEAKAGE OR FLOODING. RELATED DAMAGE AND INCIDENTALS WILL NOT BE COVERED UNDER WARRANTY OR IN ANY OTHER MANNER BY AXENT.

### FILTER CLEANING

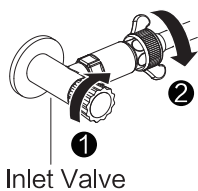

Inlet Valve

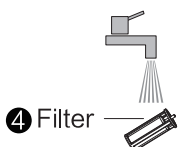
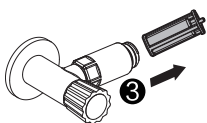

Filter

The filter screen will need to be cleaned frequently. If the unit does not fill up properly, starts to lose pressure, or does not function normally, please clean the filter first.



DO NOT use the product without the filter. Otherwise the product may not be warranty.  
The water inlet valve must be shut off during the entire filter cleaning process.  
The filter may be reinserted in reverse after cleaning.



## MAINTENANCE

---

### CLEANING INSTRUCTIONS SEAT, LID AND BACK COVER

---

Use a mild soap solution to clean the seat. Please take care that the seat and hinges are not left damp. Dry off any residual water or cleaning agent with a soft cloth. Ensure that the seat and seat hinges do not come in contact with abrasive, corrosive, or chlorine-based cleaners, as these may cause damage or lead to flash rust. When cleaning the bowl, make sure that the seat and cover are kept in an upright position until all cleaning agent has been flushed away.



**Do NOT use any scouring equipment or tools (ex: scouring pad) or any aggressive cleaning agents for cleaning.**

### CLEANING CERAMIC APPLIANCES

---

Do not use harsh or abrasive cleaning substances such as abrasive cleansers, scouring powder or drain cleaner on your ceramic surfaces. Also avoid using steam cleaners and hard, abrasive sponges. Please do not pour or dispose of hair coloring products into the toilet as this can reduce the effectiveness of the AXENT Easy Clean coating.

By following these maintenance guidelines, AXENT Easy Clean should remain effective for many years. AXENT highly recommends the use of acidic cleaners with a pH value between 1 and 4. Cleaners with a pH value in the neutral range (5 to 8) are not always suitable. We strongly advise against using either weak or strong alkaline cleaners, i.e. substances with pH values from 9 to 12.

### SUITABLE CLEANING DETERGENTS

---

- Mild bathroom or all-purpose cleaner
- Mild detergents
- Normal toilet brushes
- Soft sponges
- Microfiber clothe

### PLACEMENT PARTS LIST

---

There will be instructions with the new replacement part.

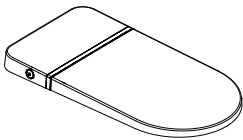

X10000000822  
Seat and Lid

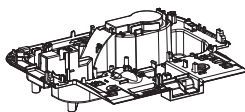

X10000000823  
Base

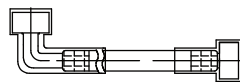

X10000000881  
Inlet Hose-set-2  
(Left: 15/16"-14UNS Right: 1/2"-  
14NPSM)

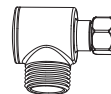

X10000001713  
Debris Filter

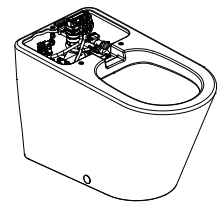

X10000002456  
Toilet Bowl

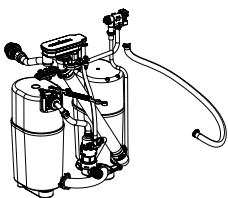

X10000002457  
Power Flush

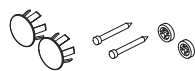

X10000000975  
Bowl Mounting Hardware /  
Plug

## TROUBLESHOOTING

---

### FREQUENTLY ASKED QUESTIONS

**IN CASE OF MINOR MALFUNCTIONS, PLEASE REFER TO THE FOLLOWING TABLE. IF THE BELOW SOLUTIONS DO NOT RESOLVE THE ISSUE, PLEASE CONTACT CUSTOMER SUPPORT FOR FURTHER EXAMINATION AND REPAIR.**

Malfunction	Cause	Solution	Page
Leaking	Connection loose	Check connection between hose and main, then tighten it.	/
No Flush	Water Supply Issue	Check water supply, and ensure that the water supply could work normally.	/
Low Flush Volume	Low water pressure	Please ensure the water pressure is over 20 psi.	/
	Slow refill time	Please wait for at least 50 seconds after previous flush.	/

### TECHNICAL DATA

---

Protection Degree	IPX4
Recommended Pressure Range	0.14 - 0.75 MPa ( 20 - 108psi )
Ambient Temperature Range	4 - 40 °C ( +39 to +104 °F )
Water Temperature Range	4 - 35 °C ( +39 to +95 °F )
Product Weight	46 kg ( 101 lbs )
Product Dimension ( L × B × H )	725 × 386 × 498 mm ( 28 <sup>9</sup> / <sub>16</sub> × 15 <sup>3</sup> / <sub>16</sub> × 19 <sup>2</sup> / <sub>3</sub> inches )
Maximum Load (Seat and Lid)	150 kg ( 330 lbs )

### TECHNICAL SUPPORT

---

For any questions or any assistance with this product, please contact your dealer or call us at

1-800-769-4857

support@axentproducts.com

www.axentbath.us

### LEGAL DIRECTIONS

---

This manual contains important information on the intended use, correct operation and proper maintenance of the equipment. Knowledge of and compliance with the instructions of this manual are provided for both the safe use of the equipment and for the safety of its operation and maintenance. In this manual, not all kinds of applications and improper manipulations are considered. In addition, attention is drawn to the following: The content of these instructions is neither part of any previous or existing agreement, commitment or legal relationship, nor does it change from an existing agreement, commitment or legal relationship. Any commitment by AXENT results from the respective warranty. These include the complete and authoritative warranty obligation AXENT. The statements in this manual do not constitute an extension or a restriction of the claims under the warranty provisions. This manual is protected by copyright. Copies and / or translations into other languages may be made only with prior written approval of AXENT.

---

## GUARANTEE

---

### AXENT LIMITED WARRANTY

---

A three-year limited warranty applies to all AXENT products purchased on or after May 1, 2019. All products purchased on or before April 30, 2019 OR purchased for use in a commercial or hospitality setting on any date are backed by AXENT's one-year limited warranty. All spare parts purchased for use with Axent products are covered by a six (6) month limited warranty unless otherwise stated on the product.

1. AXENT warrants that its products are free from defects caused by defective material and faulty workmanship for a period of three-year from the date of purchase by the original purchaser. The limited warranty is to the original purchaser only. The limited warranty is not transferable to any third party. Proof of purchase showing both original ownership and purchase date is required for any warranty claim. The limited warranty applies to all products sold by authorized dealers in the United States and Canada and used within the United States and Canada. This warranty is limited to parts only and AXENT is not responsible for any installation labor charges, removal charges, installation, or other incidental or consequential cost.
2. AXENT's sole and maximum liability for breach of its warranties herein is limited to the obligation, at AXENT's sole discretion to repair, replace, or make appropriate adjustments to bring the product back to normal operating function. AXENT reserves the right to inspection of the product and verification of normal residential usage conditions during the warranty period before warranty claims are handled. In no event shall AXENT or Seller be liable to Buyer for consequential, incidental, economic, or special damages stemming from any breach of express or implied warranty.
3. Purchaser shall comply with the following procedures in connection with the warranty claim:
  - AXENT is notified in writing by Purchaser within thirty (30) days after discovery of defects;
  - Purchaser obtains a Return Authorization from AXENT prior to returning any defective product to AXENT;
  - The defective products are returned to AXENT, all shipping charges prepaid by Purchaser (provided however, that if upon examination by AXENT, it determines that the products are entitled to warranty, then AXENT shall be responsible for shipping charge to and from AXENT's facility).
  - The defective products are received by AXENT for adjustment no later than fifteen (15) days following the last day of the warranty period; and
  - AXENT's examination of such goods shall disclose that such defects or failures have not been caused by misuse, abuse, neglect, improper installation or application, repair, alteration, damage by rain, fire or casualty or by accident or negligence in use, storage, transportation or handling.
4. This warranty does not apply to the following items:
  - Damage or loss sustained in a fire, earthquake, storm or any natural disaster etc....
  - Damage or loss resulting from any unreasonable use, misuse, abuse, negligence or improper care, improper cleaning or maintaining of the product.
  - Damage or loss as a result of the use of in-tank toilet cleaners.
  - Damage or loss resulting from any sediments or foreign matter contained in the water system.
  - Damage or loss from improper installation, harsh environment, improper removal and water pressure in excess of 80PSI.
  - Damage or loss resulting from electrical surges, lightning strikes or other acts which are not considered normal or the fault of AXENT.
  - Damage or loss resulting from normal wear and tear, such as gloss reduction or dulling, scratching or fading over time due to normal use, cleaning practices, water or atmospheric conditions including but not limited to: bleach, alkali, acid cleaners, dry powdered cleaners or any other abrasive cleaning agents or abrasive cleaning tools or aids.
  - The use of any product in a manner outside of the product instructions / owner's manuals.
  - AXENT shall not be liable for any failure caused by chloramines in the public treated waters or cleaners containing chlorine (calcium hypochlorite). Please note that use of high concentrate chlorine or chlorine related products can damage fittings. This damage can cause leakage resulting in property damage.
5. AXENT'S OBLIGATION TO HONOR THESE WARRANTIES IS CONTINGENT UPON AXENT'S RECEIPT OF PAYMENT IN FULL FOR THE GOODS ENTITLED TO THIS WARRANTY. AXENT DISCLAIMS ALL OTHER WARRANTIES, EXPRESS, IMPLIED, OR STATUTORY, INCLUDING, WITHOUT LIMITATION, THE IMPLIED WARRANTIES OF MERCHANTABILITY AND FITNESS FOR A PARTICULAR PURPOSE. SELLER HAS NOT AUTHORIZED ANYONE TO MAKE ANY REPRESENTATION OR WARRANTY OTHER THAN AS PROVIDED ABOVE. THE FOREGOING STATES THE ENTIRE WARRANTY LIABILITY OF SELLER.

To obtain warranty service, contact AXENT's service team through your dealer or plumbing contractor, or via the points of contact below:

**Mailing Address: Attn. Customer Service Department 3 Musick, Irvine, CA 92618**

**E-mail: [Support@axentproducts.com](mailto:Support@axentproducts.com)**

**Phone: 1-800-769-4857**

Place serial number sticker here  
for reference



**AXENT Intelligence Inc.**

[www.axentbath.us](http://www.axentbath.us)  
[support@axentproducts.com](mailto:support@axentproducts.com)  
1-800-769-4857