



Residential Gas Condensing High Efficiency Tankless Water Heaters

15-Year Residential/10-Year Commercial Heat Exchanger Limited Warranty/5-Year Parts Warranty*

FEATURES

Ultra-Low NOx Condensing Technology Provides 0.93 Energy Factor (EF)

Complies with California SCAQMD Rule 1146.2 and other Air Quality Management Districts with similar NOx emission requirements of 14 ng/J or 20 ppm

Operates on 1/2" Gas Line with Standard Gas Pressure

Durable Heat Exchanger

- Copper Primary Heat Exchanger
- Secondary Heat Exchanger is made of Marine Grade Type 316L Stainless Steel to protect against corrosion

Continuous Maximum Flow Rates up to 6.6 GPM

ENERGY STAR® Qualified

Available in Natural Gas or Propane (LP)

GT-140-NIH & GT-140-NEH can be used in Residential Hot Water and Heating Applications (Check local codes)

Electronic Ignition - No Pilot Light

Indoor Model - Includes a Built-In Temperature Controller and Advanced Diagnostics to Simplify Troubleshooting

Outdoor Model - Includes a Wall Mount Temperature Remote Controller and Advanced Diagnostics to Simplify Troubleshooting

Factory-Installed Power Cord Included for Indoor Models

Complies with Lead Free Standards

Safety Features:

- Air-Fuel Ratio (AFR) Sensor
- Exhaust & Water Temperature Safety Control
- Overheat Cut-Off Fuse

Internal Freeze Protection System

Power Direct Vent Design

- Exhaust, 3" PVC Venting up to 70 feet or 4" PVC Venting up to 100 feet
- Provides flexible venting with PVC, CPVC, or ABS Pipe for Intake and Exhaust (solid core only).
- Category IV Stainless Steel venting can also be used

Accessories

- Pipe Cover
- Neutralizer Kit
- Isolation Valve Kits
- Concentric Termination
- Recess Box



**INDOOR MODEL
GT-140-NIH**



**OUTDOOR MODEL
GT-140-NEH**



ANSI Z21.10.3

*For complete warranty information consult the written warranty of American Water Heaters found at www.americanwaterheater.com, or call (800) 999-9515.



Residential Gas Condensing High Efficiency Tankless Water Heaters

Tankless High Efficiency Condensing Models

MODEL NUMBER	FUEL TYPE	GAS CONSUMPTION INPUT		INLET GAS PRESSURE		ENERGY FACTOR	MAX GPM*	GAS CONN.	HOT/ COLD GAS CONN.	DIMENSIONS IN INCHES			UNIT WEIGHT (LBS)
		MIN. BTU/H	MAX. BTU/H	MIN. W.C.	MAX. W.C.					A HEIGHT	B WIDTH	C DEPTH	
INDOOR													
GT-140-NIH	Natural	15,000	120,000	5.0	10.5	0.93	6.6	1/2" NPT	3/4" NPT	22-7/8	13-7/8	10-13/16	44
GT-140-PIH	Propane	15,000	120,000	8.0	14.0	0.93	6.6	1/2" NPT	3/4" NPT	22-7/8	13-7/8	10-13/16	44
OUTDOOR													
GT-140-NEH	Natural	15,000	120,000	5.0	10.5	0.93	6.6	1/2" NPT	3/4" NPT	22-7/8	13-7/8	10-13/16	44
GT-140-PEH	Propane	15,000	120,000	8.0	14.0	0.93	6.6	1/2" NPT	3/4" NPT	22-7/8	13-7/8	10-13/16	44

All dimensions are in inches.

15-150 psi Water Pressure. 40 psi or above is recommended for maximum flow.

*Current numbers based on factory testing; 0.5 gpm required for activation; 0.4 gpm required for continuous fire after initial ignition.

Indoor models are certified from sea level to 10,100 ft. elevations.

In accordance with ANSI Z21.10.3, CO emission does not exceed 400 PPM for normal input.

The manufacturer reserves the right to discontinue, or change at any time, specifications or designs without notice and without incurring obligation.

INDOOR MODEL

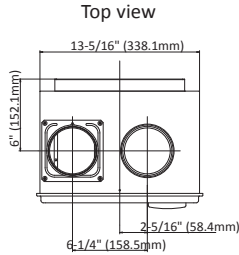
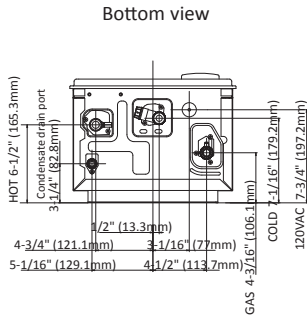
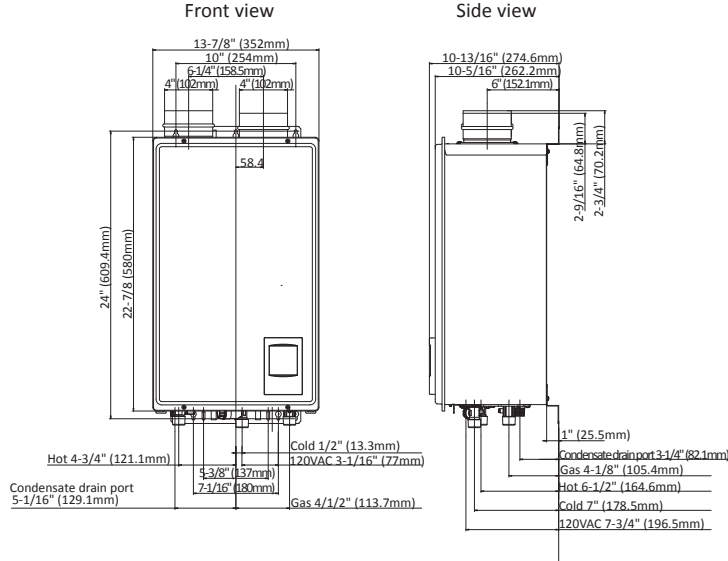

OUTDOOR MODEL

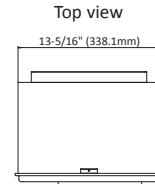
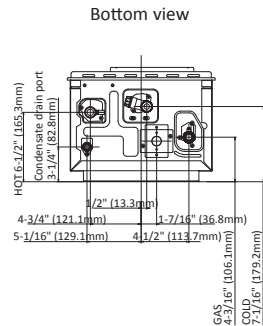
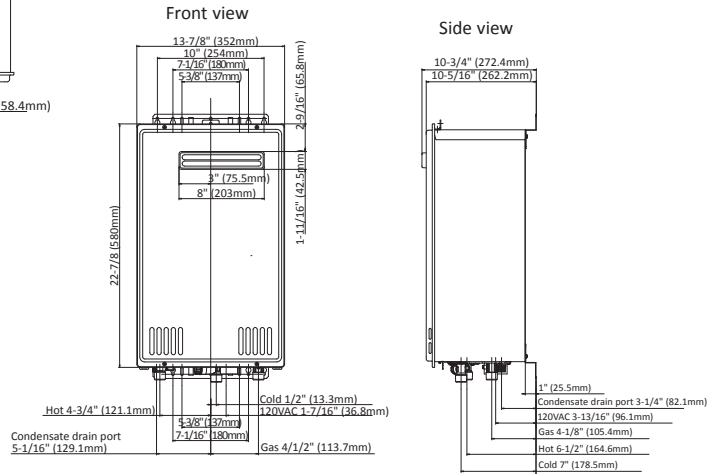



Residential Gas Condensing High Efficiency Tankless Water Heaters

Flow Rate vs. Temperature Rise

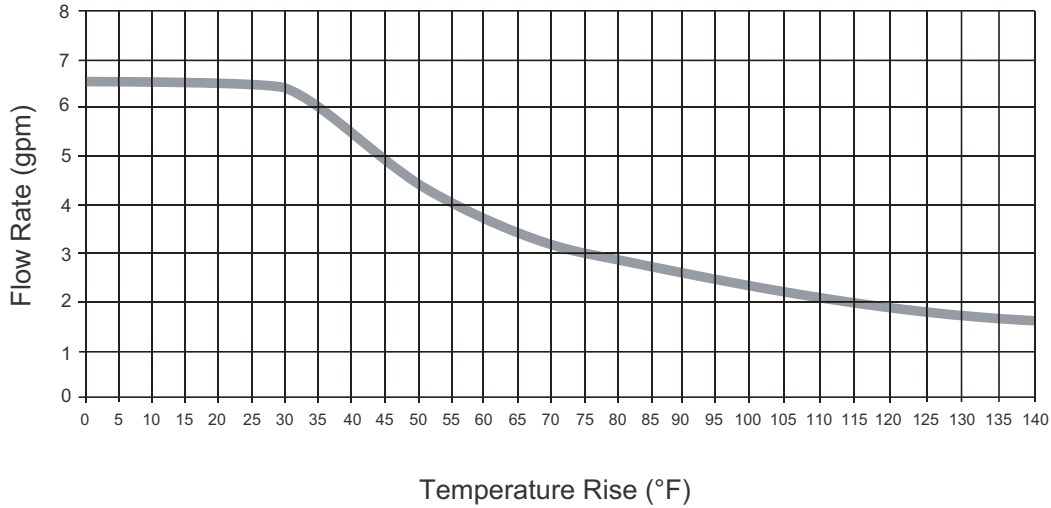

Pressure loss

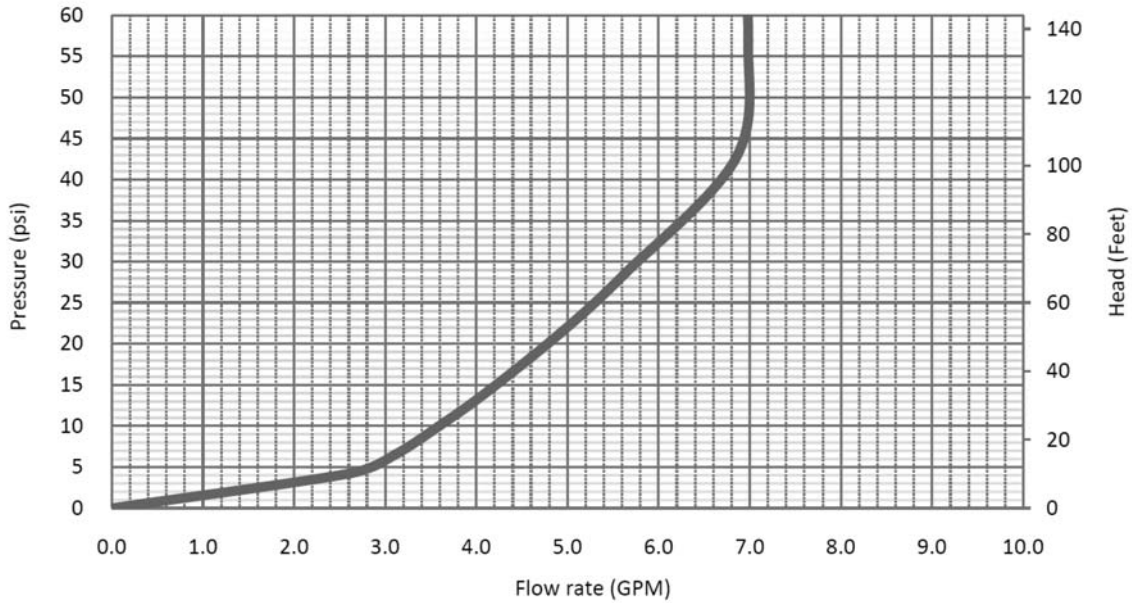

Distributed By:

Order Entry and Sales

500 Princeton Road (FEDEX, UPS)
 Johnson City, TN 37601-2030
 P. O. Box 4056 (Mailing)
 Johnson City, TN 37602-4056
 (800) 937-1037
 FAX (800) 581-7224

Warranty and Service

500 Princeton Road (FEDEX, UPS)
 Johnson City, TN 37601-2030
 P. O. Box 1597 (Mailing)
 Johnson City, TN 37601
 (800) 999-9515
 FAX (800) 999-5210