



American Standard

The American Standard 32" x 52" Gelcoat walk-in bath provides a similar bathing experience to larger models but fits in smaller spaces and uses less water. The included tub extender allows this tub to retrofit in the same space as a standard bathtub. The full sized, outward opening, contoured door with a low door threshold allows ease of entry and exit.

Fully equipped, the 709 Value Series offers all the latest in safety and comfort features with the most advanced therapeutic options and backed by a lifetime warranty on the door seal, a 10 year warranty on the tub shell and a 5 year warranty on all other components.

Whirlpool Massage



A soothing and invigorating water jet massage system, the Whirlpool massage features an in-line heater and Legs-Only massage. Customize back and leg muscle therapies with 6 different water jets. The Whirlpool Spa is combined with all of the features of the Soaker Tub providing an enhanced therapeutic bathing experience.

Combination System



Combines all of the features of the Soaker Tub, the Whirlpool Massage, and the Air Spa Systems, plus a multi-colored Chromatherapy light system for the ultimate therapeutic bathing experience. The Air Spa Systems provides a soft and caressing all-over body massage powered by a single speed heated blower that releases thousands of air bubbles rising throughout the water from 21 different air jets. The automatic purge cycle helps keep the system running efficient and clean. The Air Spa is combined with all of the features of the Soaker Tub providing an enhanced therapeutic bathing experience.

Quick Drain® System



Spend less time waiting with this patented innovation, that requires no additional plumbing, once activated it rapidly pumps the water out from within the tub-making it safe to open the door and exit the tub. Included in all systems.

C3252OD.709-PC VALUE SERIES 32" X 52" WALK-IN BATH

C3252OD.709.SXX-PC Soaking Tub

- Tub Extender Kit to fill 60" space
- Available in White with Left Hand or Right Hand Door/Drain Configuration
- Outward opening door with watertight door system with a lifetime warranty on the door seal
- Built-in chair height seat
- Polished chrome trim and cable driven waste and overflow
- Built-in safety bar and textured tub floor
- Patented Quick Drain® fast water removal system
- Premium fast-fill tub faucet and handheld showering wand
- Full seat transfer

C3252OD.709.WXX-PC Whirlpool Massage System Combines all of the features of the Soaking Tub, plus:

- Whirlpool in-line heater
- 6 massage jets with variable flow
- Legs-only massage

C3252OD.709.CXX-PC Combination System Combines all of the features of the Soaker Tub and the Whirlpool Massage for the ultimate therapeutic bathing experience, plus:

- 21 seat and floor air injectors
- Single speed heated blower
- Automatic purge cycle

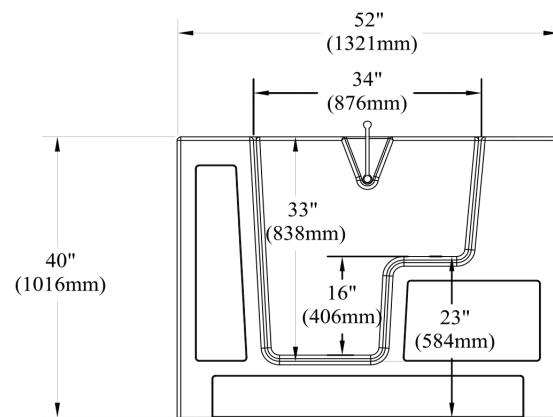
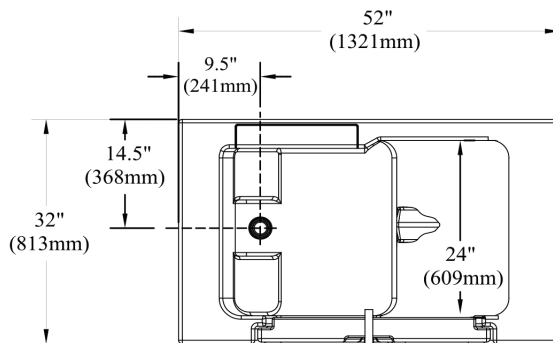

GENERAL SPECIFICATIONS FOR C3252OD.709.XXX-PC WALK-IN BATHTUB

INSTALLED SIZE	52 x 32 x 40 In. (1320 x 813 x 1016mm)
WEIGHT	161 Lbs. (73 Kg.)
WEIGHT w/WATER	828 Lbs. (376 Kg.)
OPERATING GALLON	80 Gal. (303 L.)
FLOOR LOADING (PROJECTED AREA)	72 Lbs./Sq. Ft. (351 Kgs/Sq. m.)
CUBE (FT ³)	38.5

To Be Specified - Required:

- Drain Configuration: Left (L) or Right (R)
- Color: White (W)

Options:

- Handshower Glide Bar: 9HSB
- 24 inch Grab Bar: 9GB-24
- Neck Rest: 9NR

Notes: The whirlpool heater is designed to maintain water temperature during operation. It will not heat cold water to desired bathing temperature. Tub is supported by the frame and five integrated adjustable feet, no additional support required. Refer to installation instructions supplied with tub for additional information. Provide suitable reinforcement to sub floor for all supports.

Our products are in compliance with the following codes: Uniform Plumbing Code UPC®; National Plumbing Code of Canada; International Plumbing Code IPC®

Our products conform to the following standards: ASME A112.19.7, ASME A112.19.15; CSA B45, CSA B45.5; CSA C22.2 No. 218.2; UL-1795; ANSI Z124.1.2

Our products are listed with: c ETL us

IMPORTANT: Dimensions of fixtures are nominal, may vary and are subject to change or cancellation. No responsibility is assumed for use of superseded or voided leaflet.

American Standard