

TIMES SQUARE™

PRESSURE BALANCING BATH AND SHOWER TRIM KITS

Thank you for selecting American-Standard...the benchmark of fine quality for over 100 years.

To ensure that your installation proceeds smoothly--please read these instructions carefully before you begin.

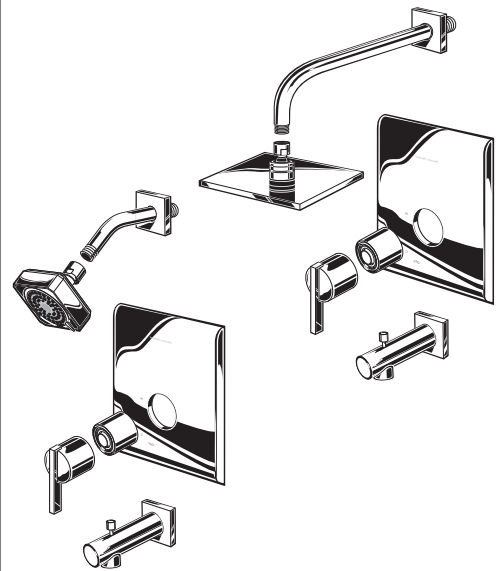

Certified to comply with ANSI A112.18.1
M965471 Rev. 1.2 (5/18)

Recommended Tools

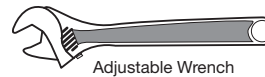
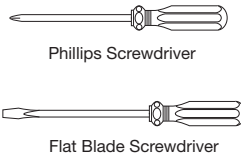
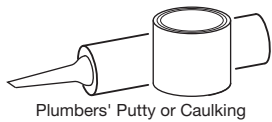

ROUGHING-IN DIMENSIONS (For reference only)

■ To assure proper positioning in relation to wall, note roughing-in dimensions.

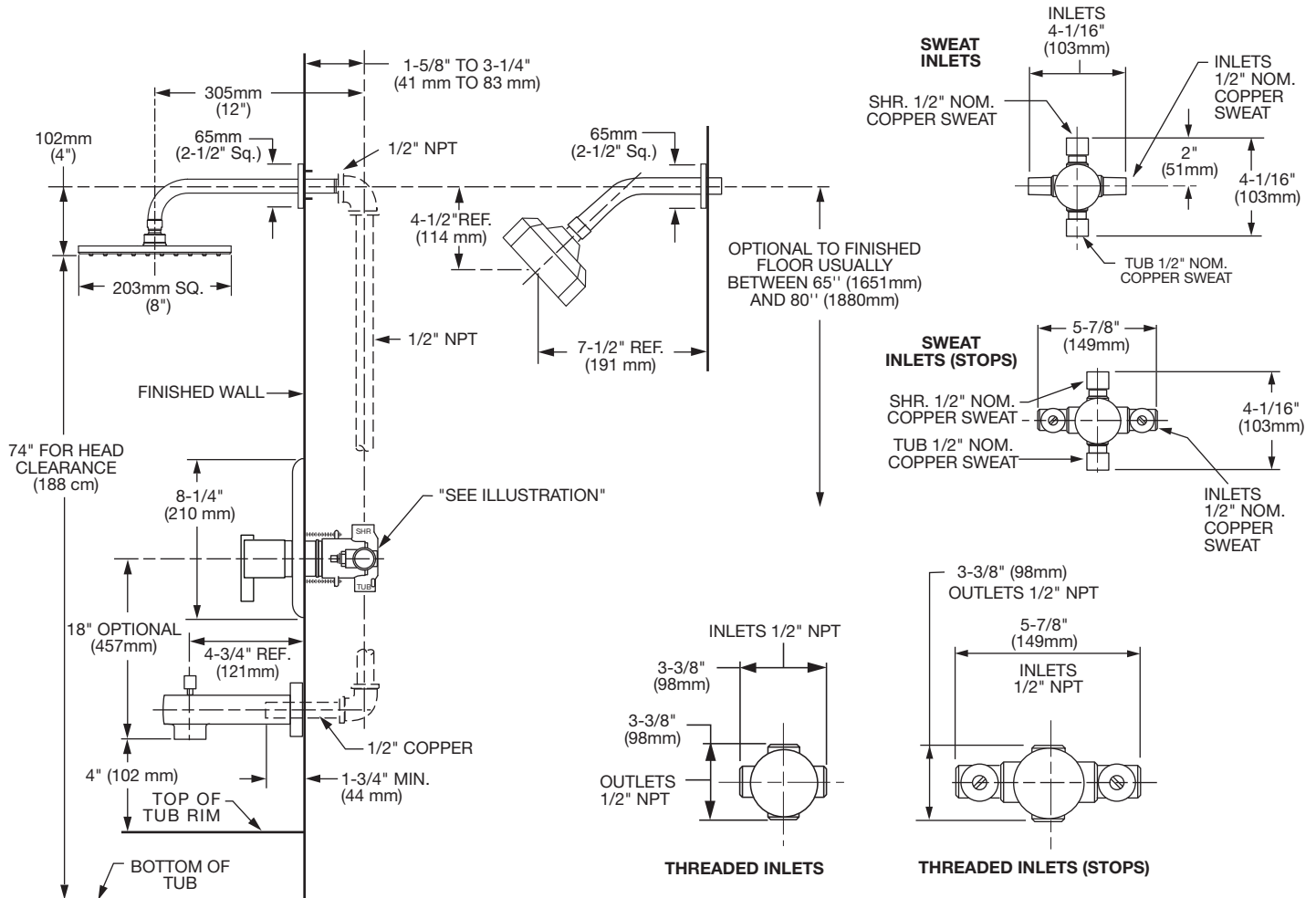

1 INSTALL VALVE TRIM

- **Figure 1.** Remove plaster guard from valve. Push CAP (1) over VALVE CARTRIDGE (2) until seated against stop.
- **Figure 2.** Make sure O-RING (8) is secure within ESCUTCHEON HOLDER (3). Push ESCUTCHEON HOLDER (3) onto CAP (1) and attach with LONG SCREWS (4). Mount ESCUTCHEON SUPPORT (5) to ESCUTCHEON HOLDER (3) with 4 SHORT SCREWS (6).
- **Figure 3.** Install ESCUTCHEON (7) onto CAP (1) and push flush against finished wall. Escutcheon (7) will snap fit onto ESCUTCHEON SUPPORT (5).

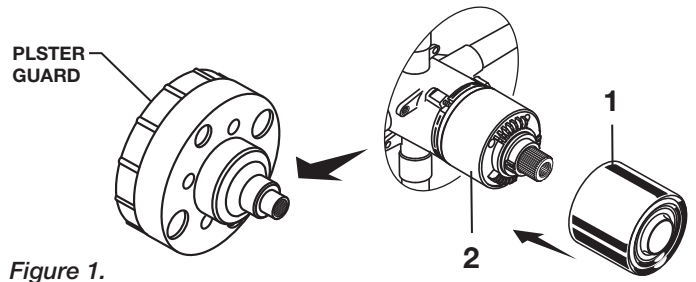

Figure 1.

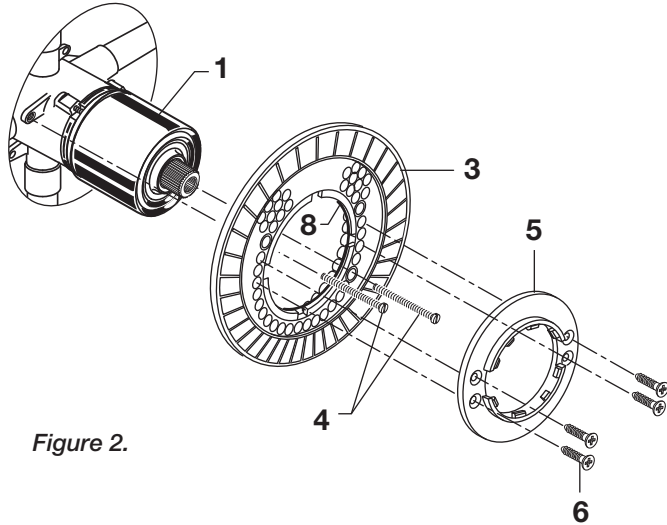

Figure 2.

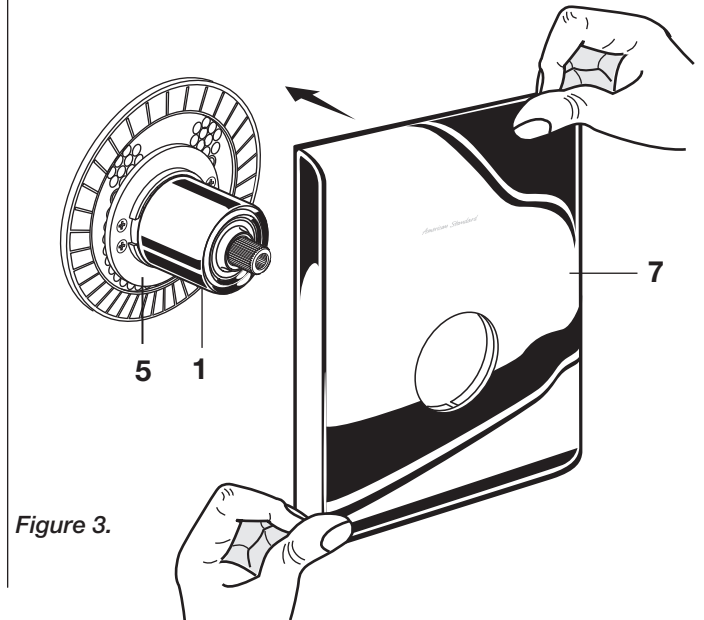
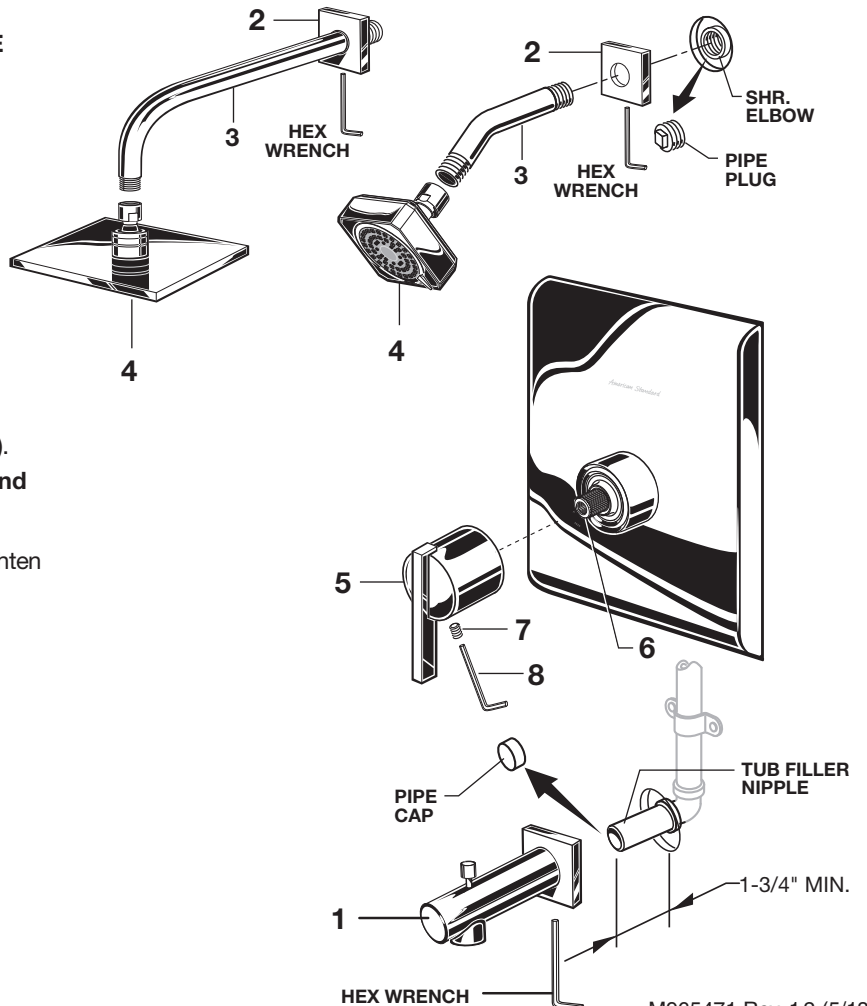

Figure 3.

2 INSTALL, TUB SPOUT, SHOWER HEAD, SHOWER ARM WITH FLANGE AND HANDLE

- Remove pipe cap and plug from shower and tub rough piping.
- Install TUB SPOUT (1) onto tub nipple. **CAUTION: Protect finish on TUB SPOUT when installing.**
- Install SHOWER ESCUTCHEON (2) onto SHOWER ARM (3). Apply sealant or Teflon tape to threads on both ends of SHOWER ARM (3) and thread longer leg of SHOWER ARM (3) into shower elbow.
- Thread SHOWER HEAD (4) onto SHOWER ARM (3). **CAUTION: Protect finish on SHOWER HEAD and ARM when installing.**
- Install HANDLE (5) onto CARTRIDGE STEM (6). Tighten SET SCREW (7) with HEX WRENCH (8) supplied.



HEX WRENCH

3 ADJUST HOT LIMIT STOP

- By restricting HANDLE rotation and limiting the amount of hot water allowed to mix with the cold, the HOT LIMIT SAFETY STOP (1) reduces risk of accidental scalding. To set the maximum hot water temperature of your faucet, all you need to do is adjust the setting on the HOT LIMIT SAFETY STOP (1).
- Turn CARTRIDGE STEM (2) to the OFF position (coldest setting) before making adjustment to HOT LIMIT SAFETY STOP (1). Use a flat blade screwdriver to pry free the HOT LIMIT SAFETY STOP (1). Pull forward and rotate counterclockwise one number to limit hot water temperature. Use ARROW (3) on CARTRIDGE (4) and NUMBERS (5) on HOT LIMIT SAFETY STOP (1) for indication.

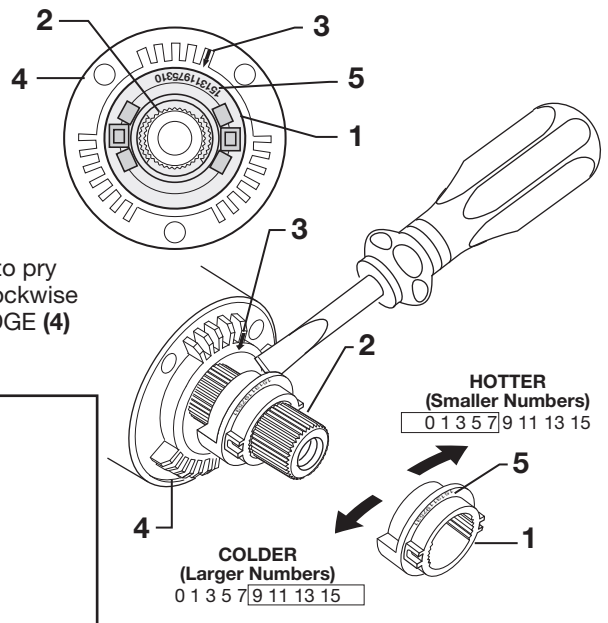

4 TO GAIN ACCESS TO VALVE FOR SERVICING

- Remove HANDLE (see step 2 and reverse).
- Remove ESCUTCHEON and CARRIDGE CAP (see step 1 and reverse). Shut off water supply by either closing off main water supply, or closing off the hot and cold CHECK STOPS on valve.

VALVE LEAKS WHEN SHUT OFF

- Remove CARTRIDGE (1) by removing CARTRIDGE SCREWS (2). Remove three SCREWS (3) from FIXATION RING (4) and pull out PRESSURE BALANCING (5) unit.
- Clean SEALS (9) on base of CARTRIDGE (1). Check base of PRESSURE BALANCING UNIT (5) and clean O-RINGS (6). Remove CAPS (7) and check O-RINGS on inside of CAPS (7). Clean inside sealing surfaces of VALVE BODY (8).
- Re-assemble PRESSURE BALANCING UNIT (5) and CARTRIDGE (1). Tighten all screws.
- Turn on water supply and see above for installing TRIM and HANDLE.

UNABLE TO MAINTAIN CONSTANT TEMPERATURE

- Remove PRESSURE BALANCE UNIT (5).
- Remove CAPS (7) and clean valve thoroughly.
- Examine balancing unit and check condition of O-ring on end of piston. Piston should move back and forth. Order Repair Part M952100-0070A if balancing unit is defective.
- Replace CAPS (7) and install PRESSURE BALANCE UNIT (5). Make sure inlets line up with two holes in bottom of casting. Top flange should butt-up against top of casting.

BACK TO BACK INSTALLATION

- Remove PRESSURE BALANCE UNIT (5). Rotate PRESSURE BALANCE UNIT (5) 180° so that the inlets face up and the large outlet port faces down.
- Push PRESSURE BALANCE UNIT (5) in casting make sure inlets line up with holes in bottom of casting. Top flange should butt up against top of casting.
- Reassemble FIXATION RING (4) and CARTRIDGE (1).

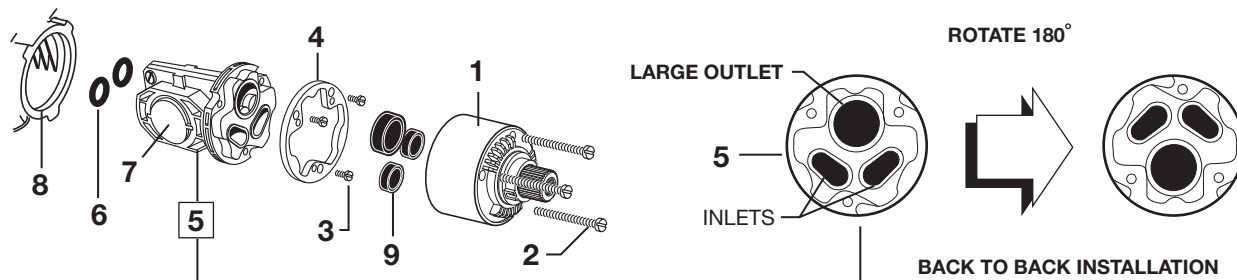

5 CARE INSTRUCTIONS:

DO: SIMPLY RINSE THE PRODUCT CLEAN WITH CLEAR WATER. DRY WITH A SOFT COTTON FLANNEL CLOTH.

DO NOT: DO NOT CLEAN THE PRODUCT WITH SOAPS, ACID, POLISH, ABRASIVES, HARSH CLEANERS, OR A CLOTH WITH A COARSE SURFACE.

T184.50X Series

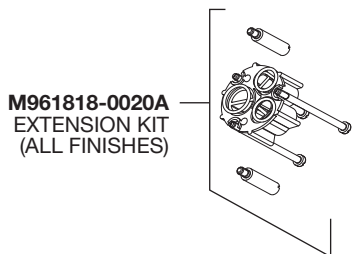
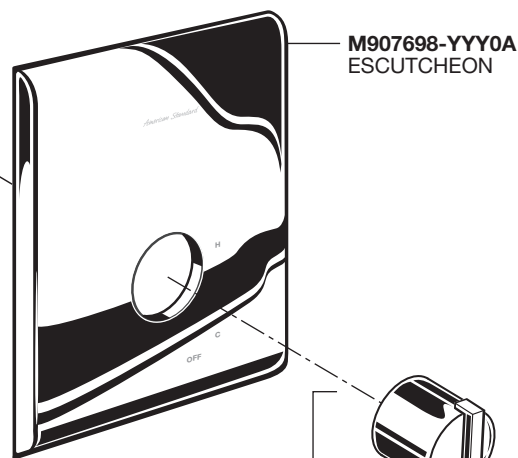
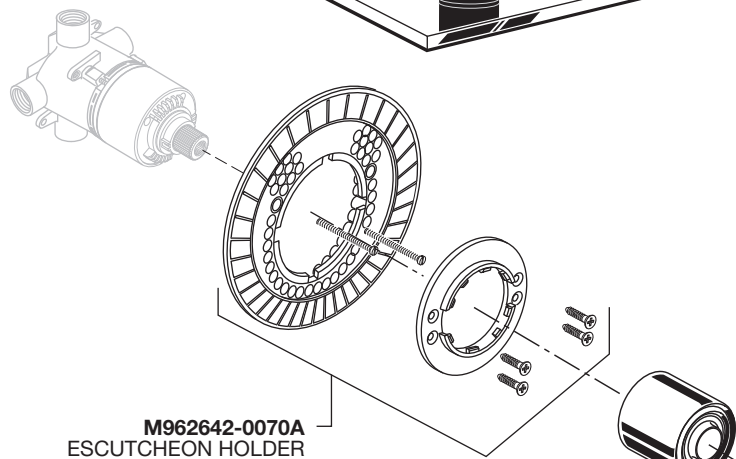
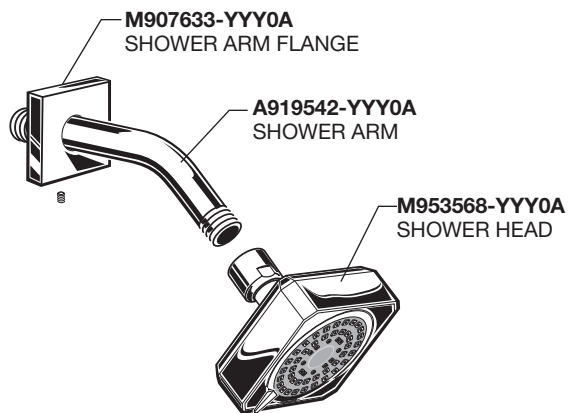
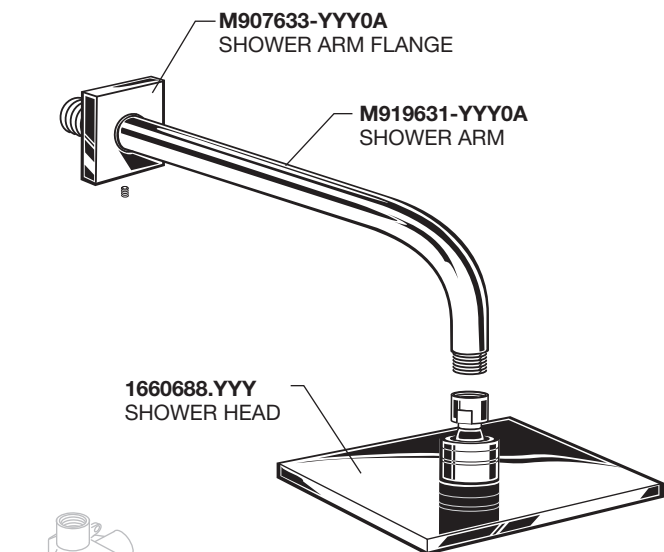

Replace the "YYY" with appropriate finish code

CHROME	002
SATIN NICKEL	295



HOT LINE FOR HELP

For toll-free information and answers to your questions, call:
1 (800) 442-1902
Mon. - Fri. 8:00 a.m. to 8:00 p.m. EST
Saturday 10:00 a.m. to 4:00 p.m. EST
IN CANADA 1-800-387-0369
(TORONTO 1-905-306-1093)
Weekdays 8:00 a.m. to 7:00 p.m. EST
IN MEXICO 01-800-839-1200



Product names listed herein are trademarks of AS America, Inc.
© AS America, Inc. 2018

PART OF LIXIL

M965471 Rev. 1.2 (5/18)