

Actuation



section R

CS & CL SERIES

FEATURES



CS and CL electric actuators are split phase reversing AC motors for standard duty or brushless DC Motors for continuous duty. Eight sizes are available which produce breakaway torques between 150 and 3000 lb-in. They are excellent industrial quality units capable of on/off, fail safe, and modulating applications. The efficient spur gear drive train is supported by permanently-lubricated bearings making it very secure while eliminating the potential for side loading of the output shaft.

Apollo offers as standard a 75% duty cycle AC motor. Continuous-duty brushless DC motors are also available for a range of input voltages. All units are rated for use in ambient environments from -40°F (with optional heater & thermostat) to 150°F (note that units equipped with an internal battery are rated to 130°F).

HAZARDOUS LOCATION ENCLOSURES

The standard enclosures (CS and CL) are rated for NEMA 4/4X (weather tight and corrosion resistant). The Hazardous Location enclosures are rated for NEMA 4/4X/7 & 9, Class I, Div 1, Groups C&D; Class II, Div. 2, Groups E, F, & G; Class III.

(CSA) CERTIFICATIONS

Certification by the Canadian Standards Association of either hazardous or weatherproof locations is standard on all CS & CL models.

FEATURES

- Plug-in connectors for the motor, the brake option and the heater/thermostat option
- All connectors are coded to prevent mis-wiring.
- Limit switch wires are soldered to the board - no more loose connections.
- A six position terminal strip clearly labeled so it can be wired up in the field without an instruction manual.
- Thermal overload protection (AC motors)
- Dual conduit openings; 3/4" (1/2" with supplied bushings)
- Visual position indication
- All aluminum enclosure
- Captive cover bolts on CS Series
- Manual override shaft (optional handwheel override with declutchable shaft)

CS & CL SERIES

DIMENSIONS

INTRODUCING SIMPLICITY FOR CALIBRATING MODULATING ACTUATORS

The control board brings a whole new level of simplicity to the field. It will work with either of the motor boards (115VAC or 230VAC).

FEATURES INCLUDE:

- Switch selector for 4-20mA or 0-10VDC input
- Switch selector for 4-20mA or 0-10VDC position readback
- Switch selector for either “fail in-place” or “fail to zero” upon loss of control signal (provided input power remains)
- On-board push buttons to manually position the actuator
- A “Mode Selector” switch with LEDs, which are used for:
 - “No tools” pot calibration
 - Setting Zero and span
 - Manually positioning the actuator
- An adjustable pot for speed control (motor pulsing)
- An adjustable pot for deadband adjustment
- Locked rotor protection if the actuator cannot achieve the position commanded by the control signal, it will cut power to the motor. Repeated stalls will not damage the actuator.
- Reverse acting operation with no rewiring.
- Split range operation with no rewiring.

CS DIMENSIONS

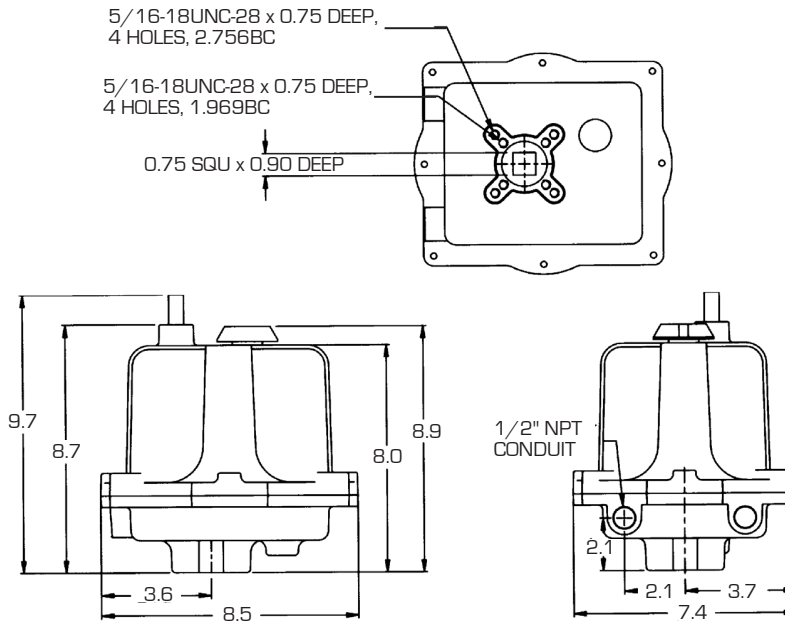

CL DIMENSIONS

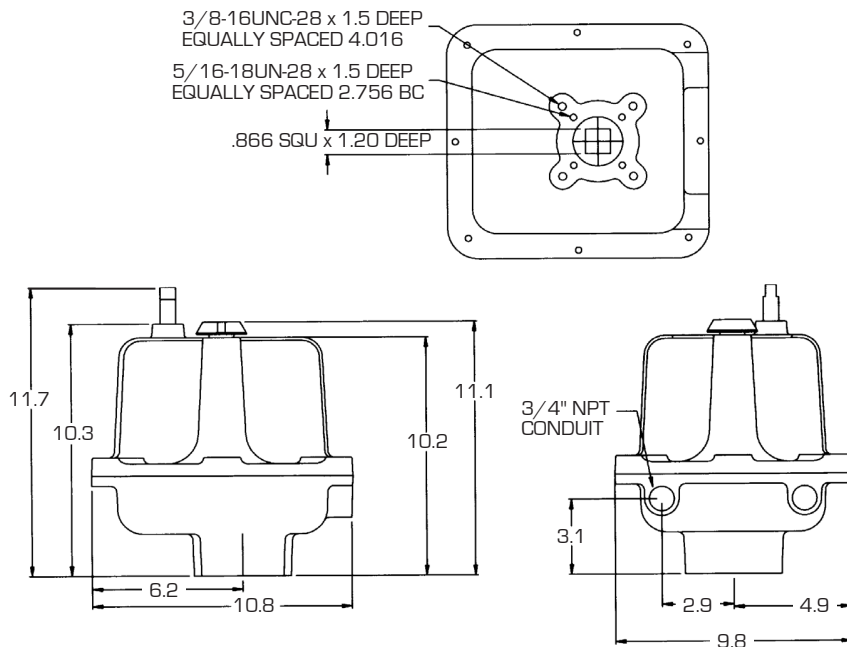

CS & CL EXTENDED DUTY DATA

TECHNICAL DATA—115VAC AND 230VAC MODELS*

SERIES	TORQUE OUTPUT (BREAKAWAY)	SPEED (SECONDS PER 90° ROTATION)	DUTY CYCLE	VA RATING		MAX RUNNING CURRENT AT FULL LOAD (TRUE RMS)		MAX EFFECTIVE PEAK INRUSH CURRENT (≈.66 X PEAK INRUSH)	
				115 VAC	230 VAC	115 VAC	230 VAC	115 VAC	230 VAC
CS	150 in lb	8	75%	70vA	115vA	0.6 amps	0.5 amps	1.25 amps	0.924 amps
	300 in lb	15	75%	70vA	115vA	0.6 amps	0.5 amps	1.25 amps	0.924 amps
	600 in lb	30	75%	70vA	115vA	0.6 amps	0.5 amps	1.25 amps	0.924 amps
CL	1000 in lb	25	75%	92vA	161vA	0.8 amps	0.7 amps	1.66 amps	1.29 amps
	1500 in lb	40	75%	92vA	161vA	0.8 amps	0.7 amps	1.66 amps	1.29 amps
	2000 in lb	55	75%	92vA	161vA	0.8 amps	0.7 amps	1.66 amps	1.29 amps
	2500 in lb	70	75%	92vA	161vA	0.8 amps	0.7 amps	1.66 amps	1.29 amps
	3000 in lb	75	55%	92vA	161vA	0.8 amps	0.7 amps	1.66 amps	1.29 amps

CS & CL CONTINUOUS DUTY DATA

SERIES	TORQUE (IN-LB)	DUTY CYCLE	12 VDC		24 VDC		24 VAC		115 VAC		230 VAC	
			CYCLE TIME (SEC/90°)	CURRENT DRAW AMPS	CYCLE TIME (SEC/90°)	CURRENT DRAW AMPS	CYCLE TIME (SEC/90°)	CURRENT DRAW AMPS	CYCLE TIME (SEC/90°)	CURRENT DRAW AMPS	CYCLE TIME (SEC/90°)	CURRENT DRAW AMPS
CS	150	100%	11	2.2	13	1.2	8	1.8	9	0.4	9	0.4
	300	100%	17	2.5	13	1.4	12	2.1	13	0.5	13	0.4
	600	100%	17	2.8	13	1.7	13	2.5	14	0.6	14	0.5
CL	1000	100%	21	4	14	2.4	15	3.5	15	0.9	15	0.6
	1500	100%	40	4	24	2.4	27	3.5	29	0.9	29	0.6
	2000	100%	40	4.3	33	2.4	28	3.5	29	0.9	29	0.6
	2500	100%	55	3.3	40	2	38	3.1	39	0.8	39	0.6
	3000	100%	60	3.7	42	2.2	40	3.5	42	0.8	43	0.6

*Notes:

1. The Current Draws stated above include all options. If the brake and/or heater & thermostat are not installed, the actual current draws will be less.
2. For Extended Duty Cycle Models, Current Draws are provided at full running torque. If the actuator encounters an overtorque condition, such as a stall condition, the Current Draw will be vastly increased.
3. Continuous Duty actuators contain brushless DC motors and are therefore not limited by duty cycle restraints in environments at or below 104°F; in ambient environments above this temperature the duty cycle is de-rated to 80%.

ACTUATOR MODEL NUMBERS/DESCRIPTION

- 115 115 VAC Motor (Standard or Continuous)
- 230 VAC 230 VAC Motor (Standard or Continuous)
- J Speed Control/Timer Board
- X NEMA 4,4X,7 & 9
- W NEMA 4 & 4X
- H Tropical Heater
- S2 Two Auxiliary Switches SPDT
- T Heater and Thermostat
- K Motor Brake²
- Z Declutchable Handwheel Override
- P Feedback Potentiometer (0-1000 Ohm)

• CSA certification with (C US) marking is standard on all standard (extended) duty models.

• CSA certification with (C US) marking is standard on continuous duty models ordered with enclosure option "E".

² Standard on continuous duty cycle units

HOW TO ORDER CS & CL EXTENDED DUTY CYCLE ACTUATOR

PART NUMBER MATRIX

SERIES	TORQUE	ENCLOSURE	GENERAL OPTIONS	DUTY CYCLE	VOLTAGE
CS	600	W	S2	E - STANDARD	115 VAC
CL	1500	X	S2	E - STANDARD	230 VAC

HOW TO ORDER CS CONTINUOUS DUTY CYCLE ACTUATOR

PART NUMBER MATRIX

3RA	CS	600	W	UL2	Z
PREFIX	SERIES	TORQUE	ENCLOSURE	OPTIONS ²	ADDITIONAL OPTIONS
3RA	CS	150 IN-LB, 12 FT-LB, 17 NM	W - NEMA 4/4X	U2 - ON/OFF/POSITION BOARD	-- NO ENTRY IF STANDARD
		300 IN-LB, 25 FT-LB, 34 NM	X - NEMA 4/4X/7&9	UL2 - ON/OFF/POSITION BOARD	Z - HANDWHEEL
		600 IN-LB, 50 FT-LB, 68 NM		W/ BATTERY BACKUP	

HOW TO ORDER CL CONTINUOUS DUTY CYCLE ACTUATOR

PART NUMBER MATRIX

3RA	CL	2500	X	UL3	-
PREFIX	SERIES	TORQUE	ENCLOSURE	OPTIONS ²	ADDITIONAL OPTIONS
3RA	CL	1000 IN-LB, 83 FT-LB, 113 NM	W - NEMA 4/4X	U2 - ON/OFF/POSITION BOARD	-- NO ENTRY IF STANDARD
		1500 IN-LB, 125 FT-LB, 169 NM	X - NEMA 4/4X/7&9	UL3 - ON/OFF/POSITION BOARD	Z - HANDWHEEL
		2000 IN-LB, 167 FT-LB, 226 NM		W/ BATTERY BACKUP	
		2500 IN-LB, 208 FT-LB, 282 NM			
		3000 IN-LB, 250 FT-LB, 339 NM			

1. All Continuous Duty Cycle CS/CL actuators accept any of the following input voltage (12VDC, 24VDC, 24VAC, 115VAC, & 230VAC), are rated for continuous duty cycle, include a holding brake, two auxiliary limit switches, 4-20mA or 0-10VDC position feedback, wrench-operated manual override, CSA "C US" certification, CE compliance, and a heater/thermostat that can be user-enabled on the option board.

2. Only one board option can (and must) be selected. All board options can be configured for On/Off or modulating operation.