

TECHNICAL SPECIFICATIONS

KDTS 3260

MODEL NUMBER 142012

DIMENSIONS: 59 7/8" x 32" x 79 1/4" Gelcoat

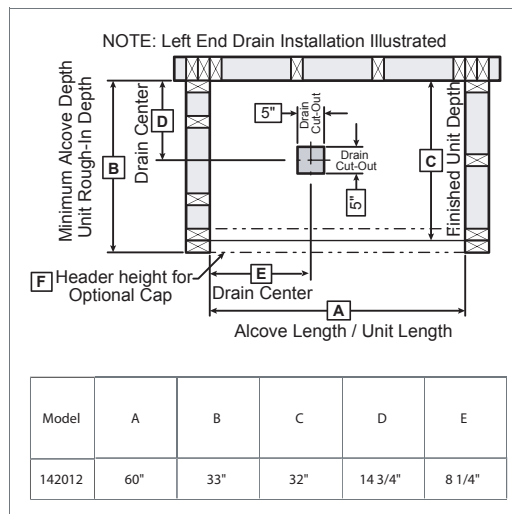

STANDARD FEATURES

- Four-piece gelcoated fiberglass tub-shower with PIN system for easy front installation
- Large top corner shelves, wide soap dish and standard acrylic handle (opt. metallic finishes)
- Bottom bathing well: 44 1/8 inch L x 21 5/8 inch W
- Optional unique features:
Reinforced walls and grab bars
- Product also available in Above-the-Floor Rough (AFR)
- Right or left-hand drain
- Textured floor
- 14 3/8 inch deep sump

UNIQUE FEATURES

- PIN system

OPTIONS

- Shower base only KDTS 3260 with pin system
- Side walls (right and left) for KDTS 3260
- Back wall for KDTS 3060, KDTS 3260, KDS 3060 and KDS 3460
- Wall reinforcement (one wall)
- In-line heater (factory-installed)
- Pump position opposite standard position

SYSTEMS

Homestead **DOOR**

SELECTION CERTIFICATIONS

Ordering with AKER's complete shower door offering visit www.akerbymax.com



Project : _____

Contractor : _____

AKER Representative : _____ Tel : _____

Date : _____

TECHNICAL SPECIFICATIONS

KDTS 3260

MODEL NUMBER 142012

TECHNICAL DRAWINGS

STANDARD

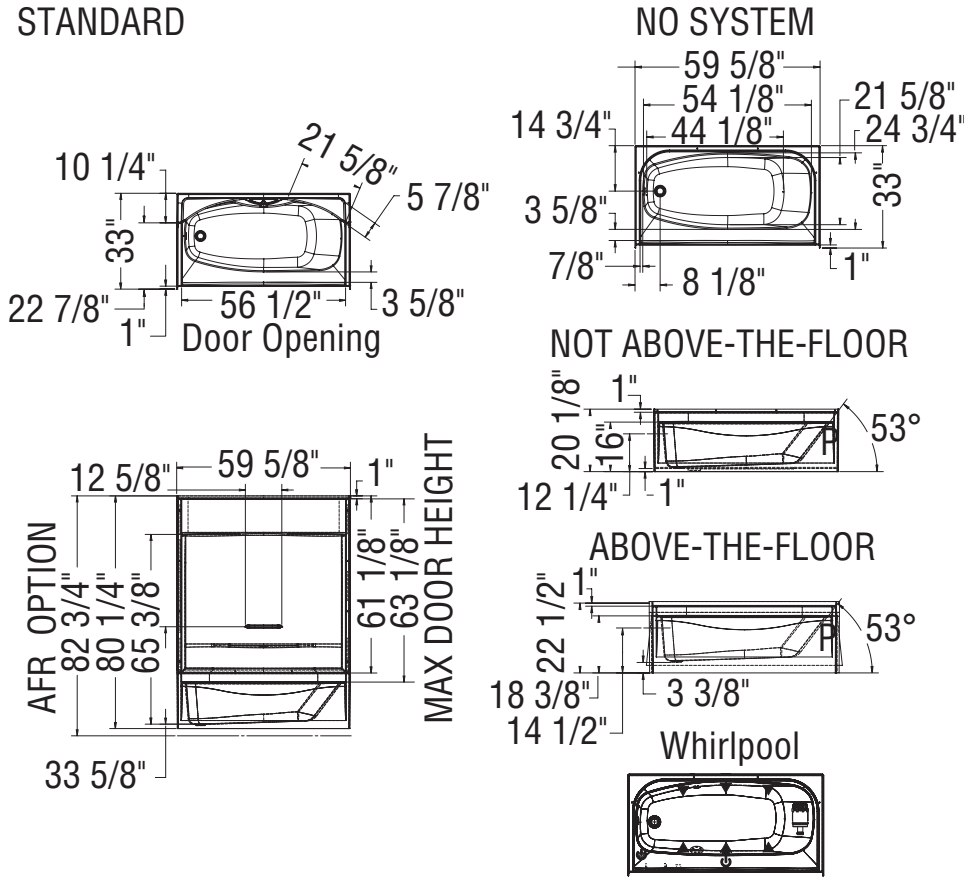

REINFORCEMENT BACKING

OPTION 20212-L Shown
OPTION 20212-R Symetrical

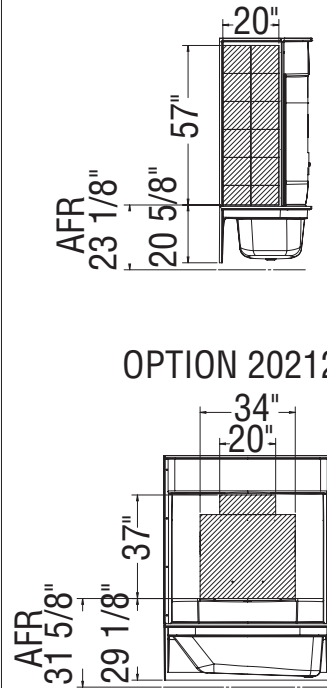

GRAB BARS

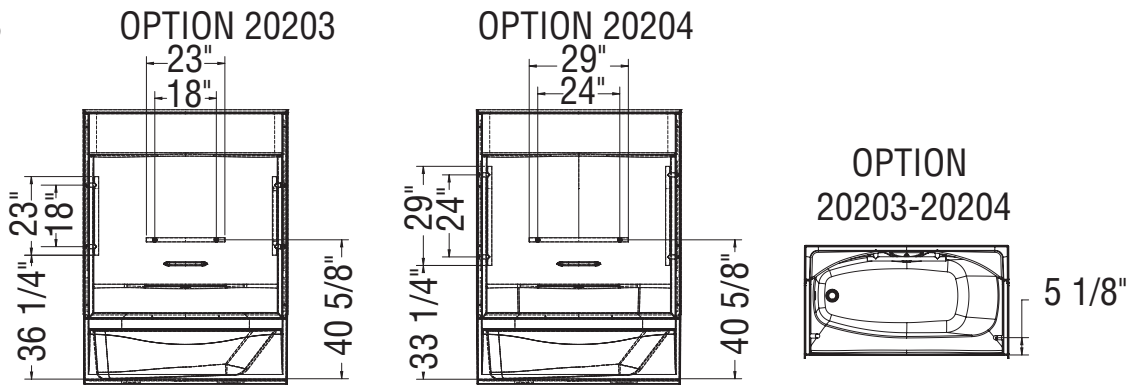

(▲): Indicates Whirlpool jets positioning

(△): Indicates suction positioning

All dimensions are approximate. Structure measurements must be verified against the unit to ensure proper fit.