

TECHNICAL SPECIFICATIONS

TOF-3060 AFR

MODEL NUMBER 142009

DIMENSIONS: 59 3/4" x 29 7/8" x 19 7/8" Gelcoat

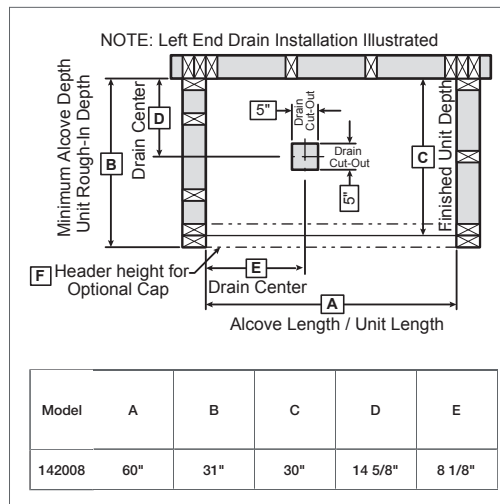

STANDARD FEATURES

- 1 1/2" wrap around backsplash
- Integrated apron and tiling flange
- 3 3/8 in. Above-the-Floor Rough
- 14 3/8" deep sump
- Bottom bathing well: 44 1/8" L x 20" W
- Textured floor
- Right or left drain
- Alcove installation

UNIQUE FEATURES

- Above-the-Floor Rough (AFR)
- Tiling Flange

OPTIONS

- In-line heater (factory-installed)
- Pump position opposite standard position
- Tile Adaptor (for door installation)

SYSTEMS

Homestead **DOOR**

SELECTION

Combine with AKER's complete shower door offering visit www.akerbymax.com

CERTIFICATIONS

AKER products adhere to one or more of the following certifications:



Project :

Contractor :

AKER Representative : Tel :

Date :

TECHNICAL SPECIFICATIONS

TOF-3060 AFR

MODEL NUMBER 142009

TECHNICAL DRAWINGS

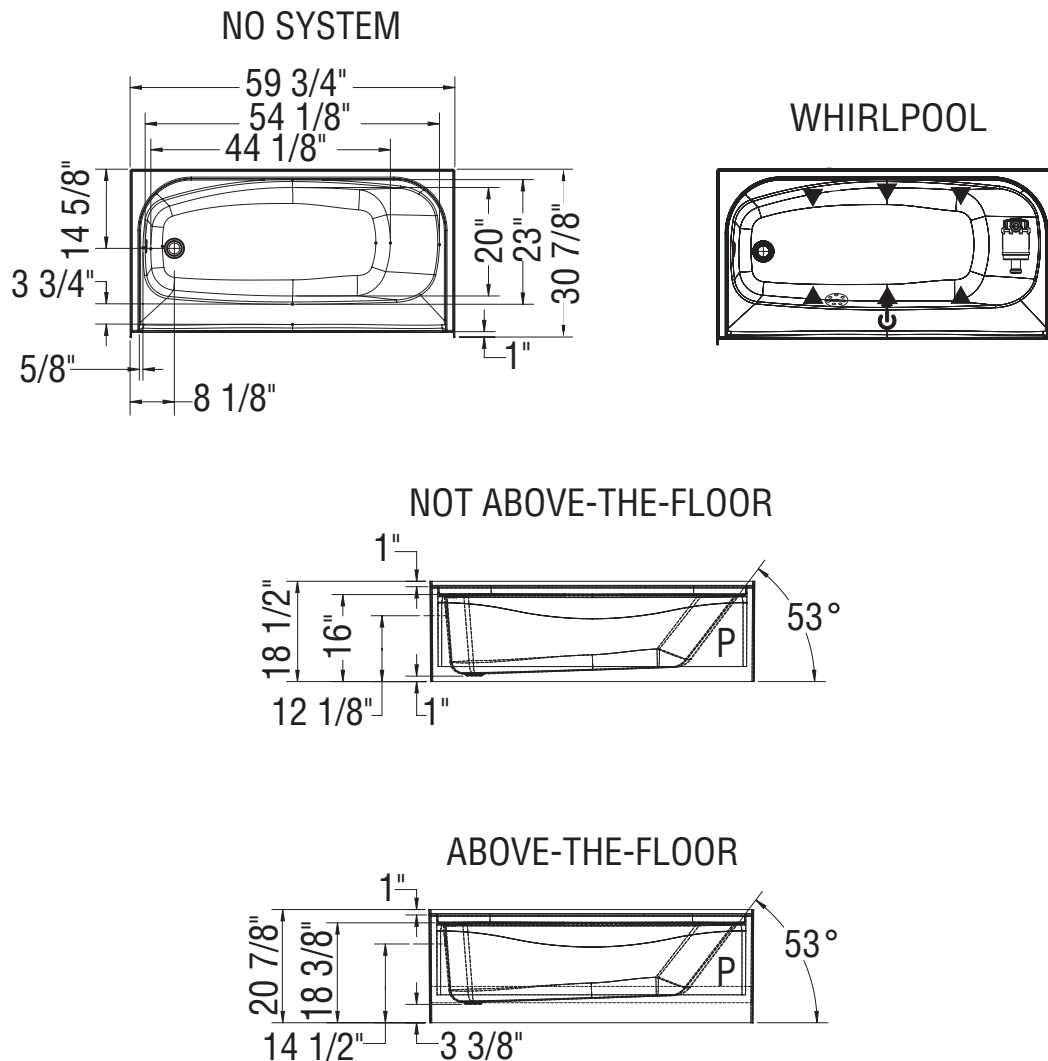

(▲): Indicates Whirlpool jets positioning
 (△): Indicates suction positioning

All dimensions are approximate. Structure measurements must be verified against the unit to ensure proper fit.