

# TECHNICAL SPECIFICATIONS

## TS-3060

**MODEL NUMBER 141132**

DIMENSIONS: 60" x 30" x 73 1/4" Gelcoat



### STANDARD FEATURES

- One-piece gelcoated fiberglass tub-shower
- Built-in back wall shelves with integrated soap dish
- Right or left-hand drain
- Textured floor
- 14 1/4 inch deep sump
- Bottom bathing well : 48 1/2 inch L x 19 3/4 inch W
- Optional unique features: Above-the-Floor Rough
- Reinforced walls

### UNIQUE FEATURES

- Above-the-Floor Rough (AFR)

### OPTIONS

- All walls reinforced
- Wall reinforcement (one wall)

### SYSTEMS

- None

### DOOR SELECTION

Combine with AKER's complete shower door offering visit [www.akerbymaax.com](http://www.akerbymaax.com)

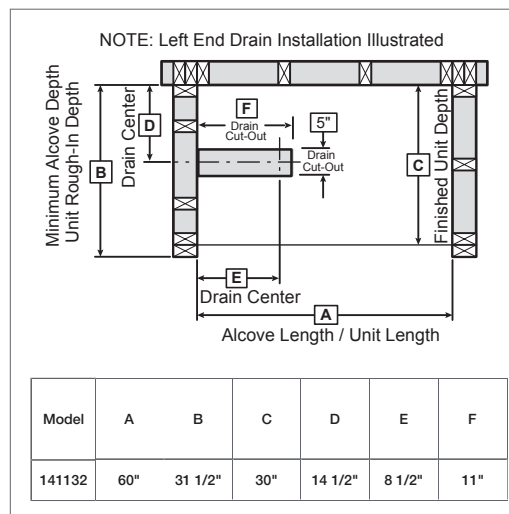

Project : .....

Contractor : .....

AKER Representative : ..... Tel : .....

Date : .....

### CERTIFICATIONS

AKER products adhere to one or more of the following certifications:



# TECHNICAL SPECIFICATIONS

## TS-3060

MODEL NUMBER 141132

### TECHNICAL DRAWINGS

With reinforcement

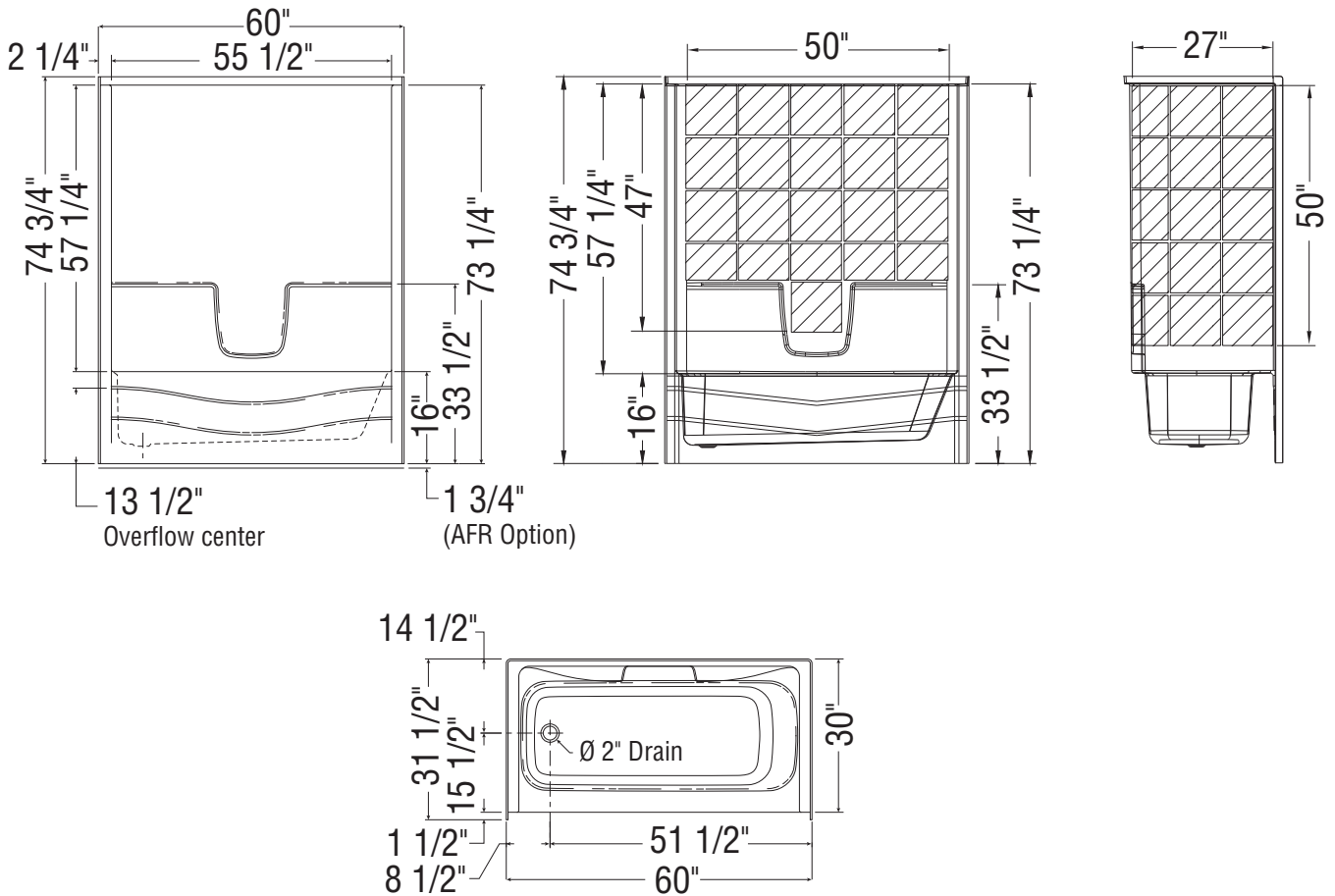

All dimensions are approximate. Structure measurements must be verified against the unit to ensure proper fit.