

TECHNICAL SPECIFICATIONS

TO-3660 AFR - Job pack of 8 AFR bathtubs

MODEL NUMBER 141360

DIMENSIONS: 60" x 36" x 17 3/4" Gelcoat



STANDARD FEATURES

- Meets FHA accessibility requirements
- Integrated tiling flange
- 2 3/4 in. Above-the-Floor Rough included
- 14 1/4" deep sump
- Bottom bathing well : 45 1/2" L x 23 1/2" W
- Textured floor
- Right or left drain
- Alcove installation
- Job pack of 8 AFR bathtubs

UNIQUE FEATURES

- Tiling Flange
- Above-the-Floor Rough (AFR)

OPTIONS

- None

SYSTEMS

- None

DOOR SELECTION

Combine with AKER's complete shower door offering visit www.akerbymax.com

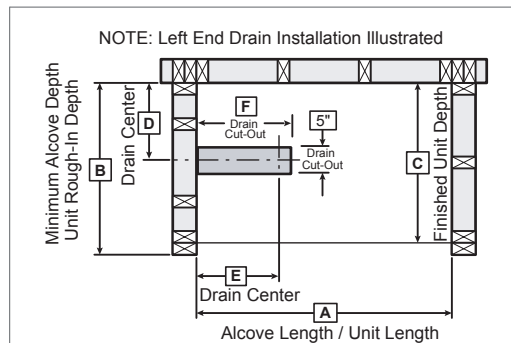

Model	A	B	C	D	E	F
141352	60	37	36	17 1/4	8	10 1/2

Project :

Contractor :

AKER Representative : Tel :

Date :

CERTIFICATIONS

AKER products adhere to one or more of the following certifications:



TECHNICAL SPECIFICATIONS

TO-3660 AFR - Job pack of 8 AFR bathtubs

MODEL NUMBER 141360

TECHNICAL DRAWINGS

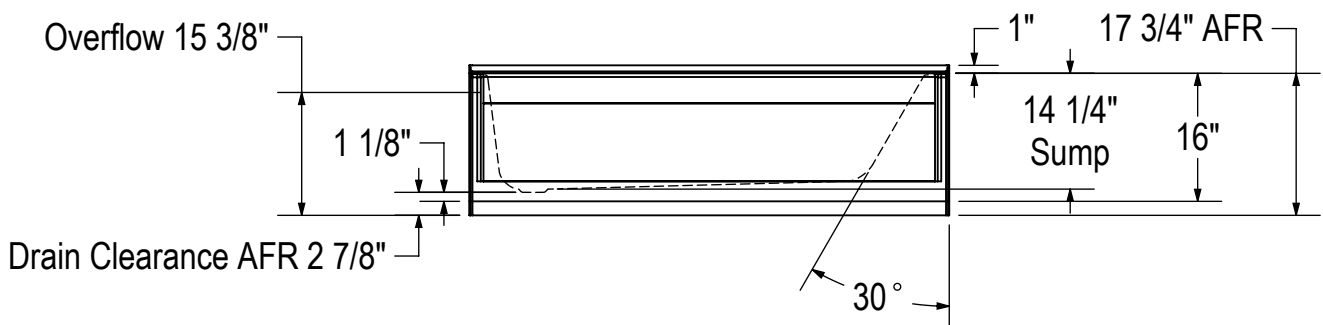
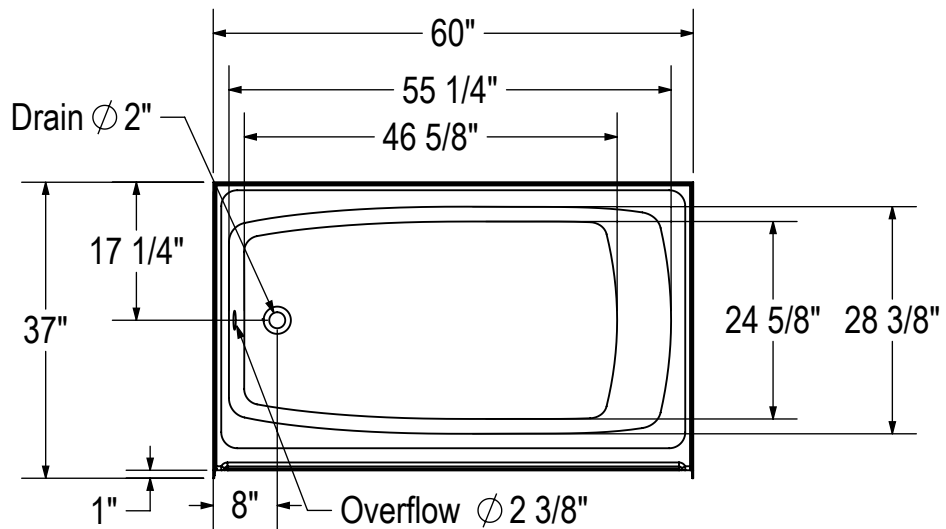

All dimensions are approximate. Structure measurements must be verified against the unit to ensure proper fit.