

TECHNICAL SPECIFICATIONS



GT-4860

MODEL NUMBER 141084

DIMENSIONS: 60" x 47 1/2" x 23 1/2" Gelcoat

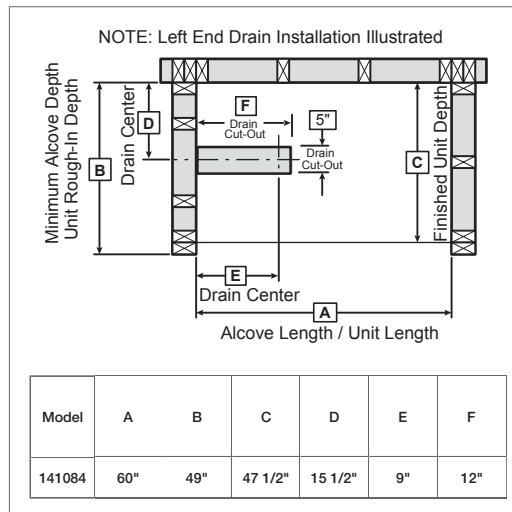

STANDARD FEATURES

- 4 inch wrap around backsplash
- Deck for faucet
- Low-profile front step with textured surface
- 17 1/2 inch deep sump
- Bottom bathing well : 44 1/2 inch L x 35 inch W
- Integrated apron & tiling flange
- Backrest with lumbar support
- Textured floor
- Right or left drain
- Alcove installation

UNIQUE FEATURES

- Tiling Flange

OPTIONS

- In-line heater (factory-installed)
- Ozonator for whirlpool system
- Pump position opposite standard position
- Trim Kit for Bodywrap Whirlpool System

SYSTEMS

Bodywrap **DOOR**

SELECTION

Combine with AKER's complete shower door offering visit www.akerbymaax.com

CERTIFICATIONS

AKER products adhere to one or more of the following certifications:



Project :

Contractor :

AKER Representative : Tel :

Date :

TECHNICAL SPECIFICATIONS

GT-4860

MODEL NUMBER 141084

TECHNICAL DRAWINGS

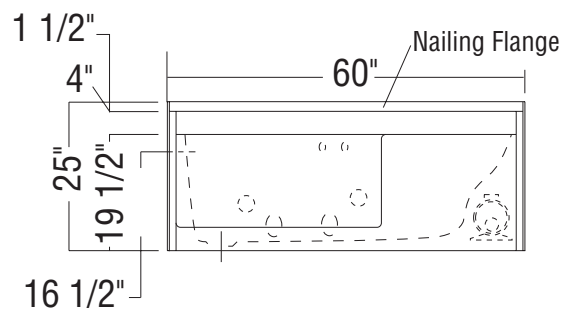
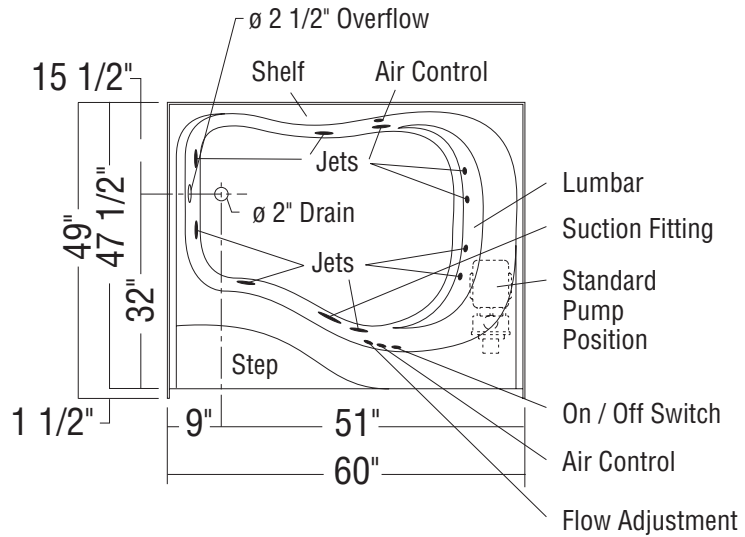
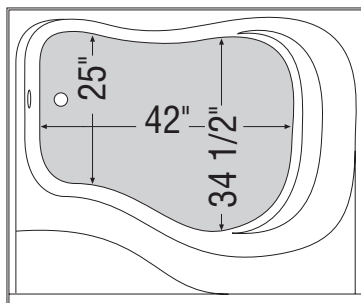

All dimensions are approximate. Structure measurements must be verified against the unit to ensure proper fit.