

TECHNICAL SPECIFICATIONS



GT-60

MODEL NUMBER 141083

DIMENSIONS: 60" x 47 1/2" x 23 1/4" Gelcoat



STANDARD FEATURES

- 5 1/2 inch wrap around backsplash
- Integrated apron & tiling flange
- Recessed front step with textured surface
- 15 3/4 inch deep sump
- Bottom bathing well: 41 inch L x 24 inch W
- Deck for faucet
- Textured floor
- Center drain

UNIQUE FEATURES

- Tiling Flange

OPTIONS

- In-line heater (factory-installed)
- Pump position opposite standard position

SYSTEMS

Homestead **DOOR**

SELECTION

Combine with AKER's complete shower door offering visit www.akerbymaax.com

CERTIFICATIONS

AKER products adhere to one or more of the following certifications:

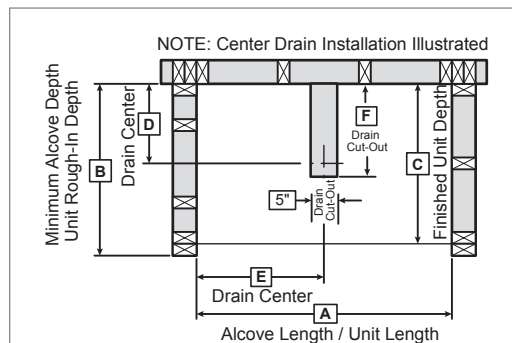

Model	A	B	C	D	E	F
141083	60"	49"	47 1/2"	11 1/4"	30"	14 1/4"

Project :

Contractor :

AKER Representative : Tel :

Date :

www.akerbymaax.com

2017-08-10

TECHNICAL SPECIFICATIONS

GT-60

MODEL NUMBER 141083

TECHNICAL DRAWINGS

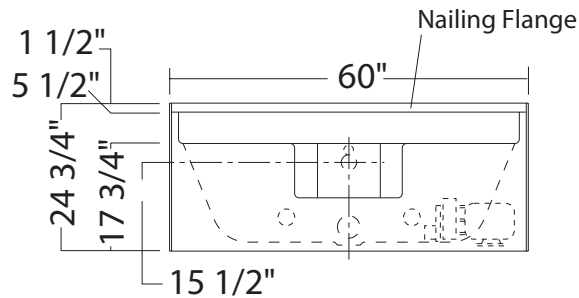
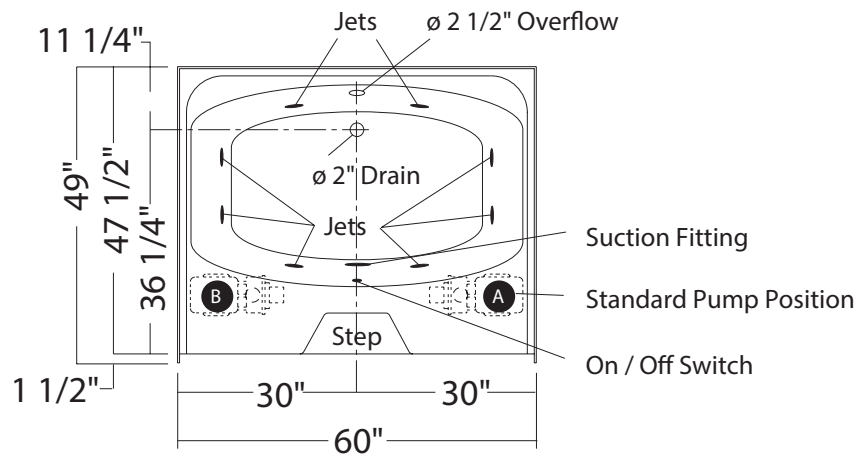

All dimensions are approximate. Structure measurements must be verified against the unit to ensure proper fit.