

# TECHNICAL SPECIFICATIONS

## KDTS 3260 AFR

**MODEL NUMBER 142013**

DIMENSIONS: 59 3/4" x 32" x 81 3/4" Gelcoat

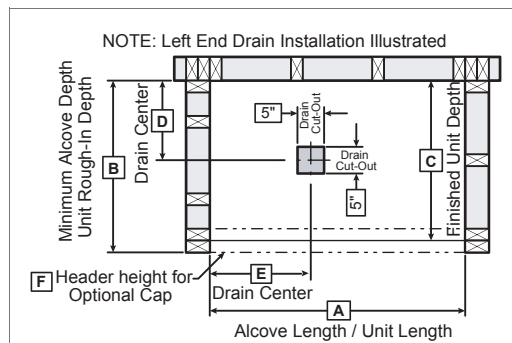

Model	A	B	C	D	E
142012	60"	33"	32"	14 3/4"	8 1/4"

### STANDARD FEATURES

- Four-piece gelcoated fiberglass tub-shower with PIN system for easy front installation
- Large top corner shelves, wide soap dish and standard acrylic handle (opt. metallic finishes)
- Right or left-hand drain • Textured floor • Bottom bathing well: 44 1/8" L x 21 5/8" W
- Optional unique features: Reinforced walls and grab bars • 14 3/8 deep sump
- Product also available in Above-the-Floor Rough (AFR)

### UNIQUE FEATURES

- Above-the-Floor Rough (AFR)
- PIN system

### OPTIONS

- Shower base only KDTS 3260 with pin system
- Side walls (right and left) for KDTS 3260
- Back wall for KDTS 3060, KDTS 3260, KDS 3060 and KDS 3460
- In-line heater (factory-installed)
- Pump position opposite standard position
- Pre-assembled unit

### SYSTEMS

Homestead **DOOR**

### SELECTION CERTIFICATIONS

Combine with AKER's complete shower door offering visit [www.akerbymaax.com](http://www.akerbymaax.com)



Project : .....

Contractor : .....

AKER Representative : ..... Tel : .....

Date : .....

# TECHNICAL SPECIFICATIONS

## KDTS 3260 AFR

MODEL NUMBER 142013

### TECHNICAL DRAWINGS

#### STANDARD

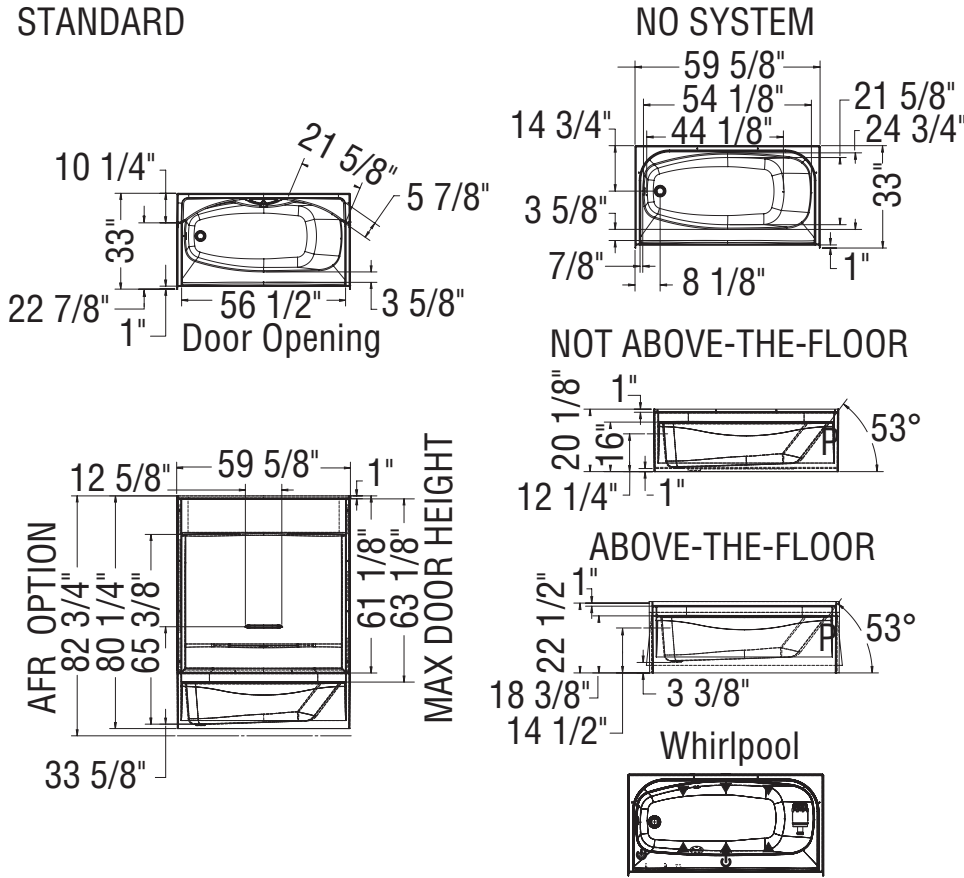

#### REINFORCEMENT BACKING

OPTION 20212-L Shown  
OPTION 20212-R Symetrical

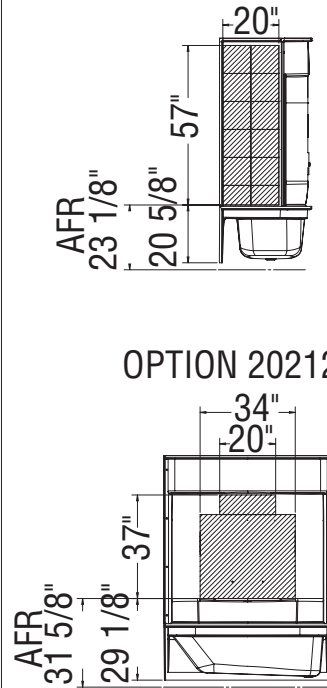

#### GRAB BARS

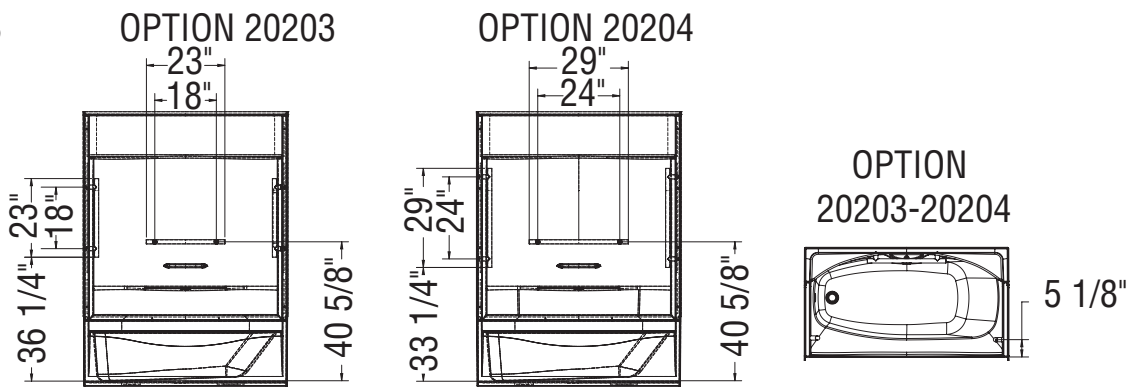

( ▲ ): Indicates Whirlpool jets positioning  
( △ ): Indicates suction positioning

All dimensions are approximate. Structure measurements must be verified against the unit to ensure proper fit.