

TECHNICAL SPECIFICATIONS

KD-NAS

MODEL NUMBER 141047

DIMENSIONS: 38" x 38" x 76 1/2" Gelcoat



STANDARD FEATURES

- Two-piece neo-angle corner shower
- Built-in corner shelf
- Center drain
- Textured floor

UNIQUE FEATURES

- None

OPTIONS

- None

SYSTEMS

- None

DOOR SELECTION

Combine with AKER's complete shower door offering visit www.akerbymax.com

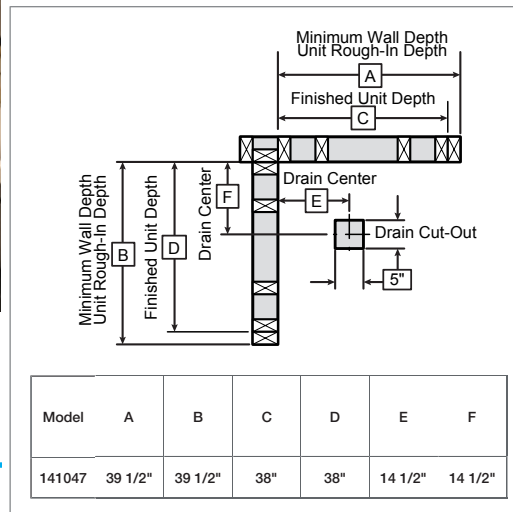

Project :

Contractor :

AKER Representative : Tel :

Date :

CERTIFICATIONS

AKER products adhere to one or more of the following certifications:



TECHNICAL SPECIFICATIONS

KD-NAS

MODEL NUMBER 141047

TECHNICAL DRAWINGS

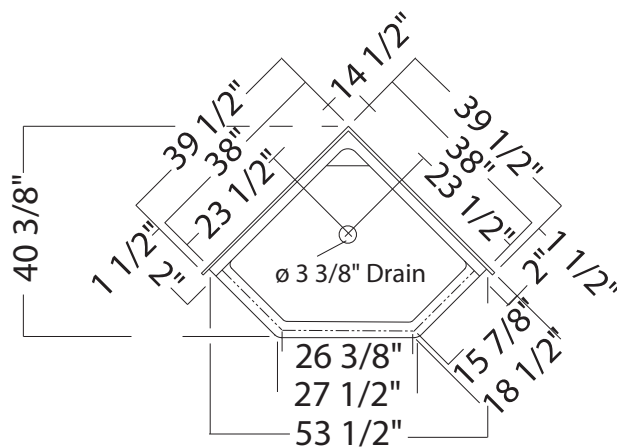
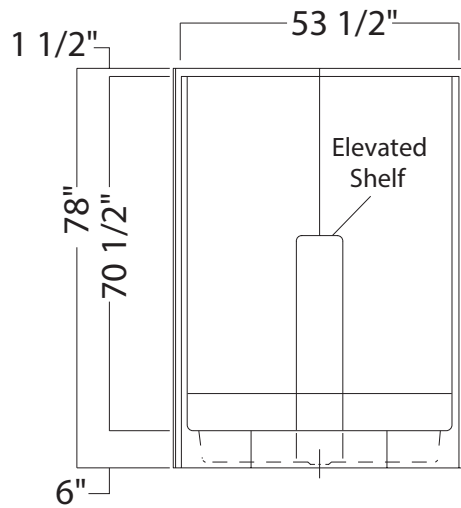

All dimensions are approximate. Structure measurements must be verified against the unit to ensure proper fit.