

TECHNICAL SPECIFICATIONS

TO-2954 - Job pack of 12 bathtubs

MODEL NUMBER 141363

DIMENSIONS: 54" x 29" x 16-17" Gelcoat



STANDARD FEATURES

- Integrated tiling flange
- 2 in. Above-the-Floor Rough available
- Textured floor
- 14 ¼" deep sump
- Bottom bathing well : 40" L x 20 ½" W
- Right or left drain
- Alcove installation
- Job pack of 12 bathtubs
- Job pack of 12 AFR bathtubs available

UNIQUE FEATURES

- Above-the-Floor Rough (AFR)
- Tiling Flange

OPTIONS

- None

SYSTEMS

- None

DOOR SELECTION

Combine with AKER's complete shower door offering visit www.akerbymax.com

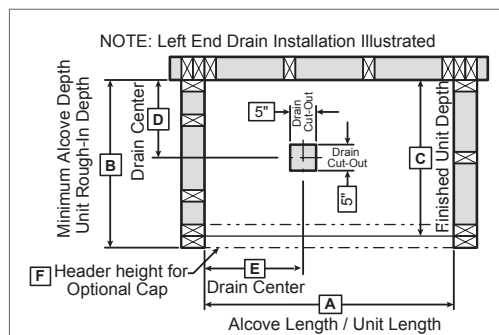

Model	A	B	C	D	E
141077	54"	30 1/2"	29"	13 1/4"	8 1/2"

Project :

Contractor :

AKER Representative : Tel :

Date :

CERTIFICATIONS

AKER products adhere to one or more of the following certifications:



TECHNICAL SPECIFICATIONS

TO-2954 - Job pack of 12 bathtubs

MODEL NUMBER 141363

TECHNICAL DRAWINGS

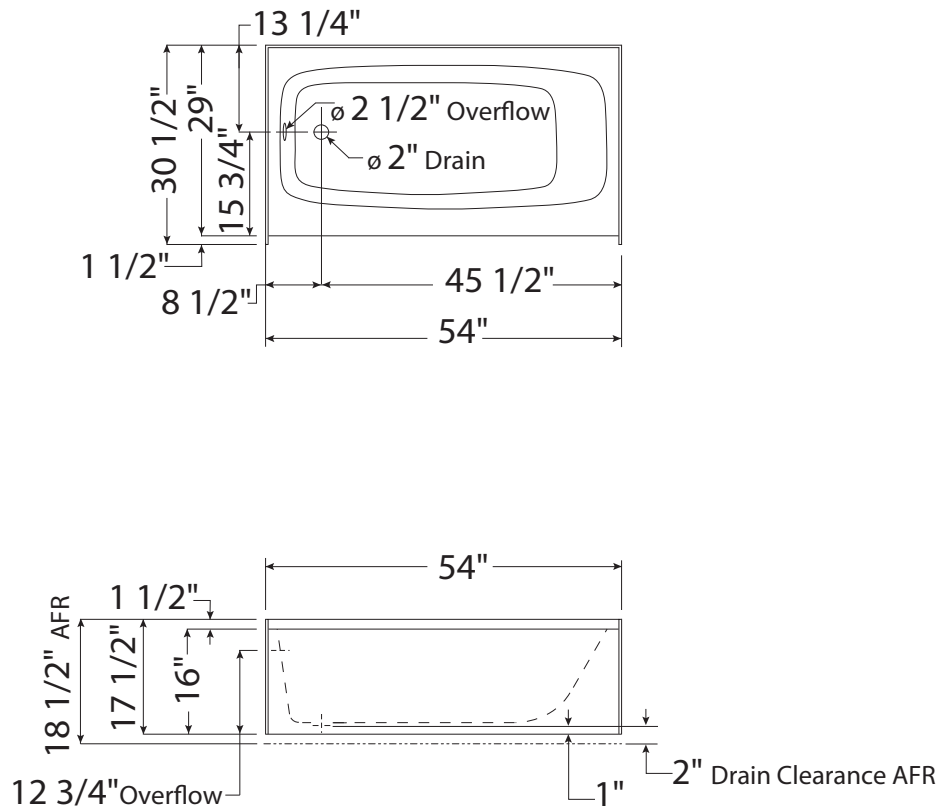

All dimensions are approximate. Structure measurements must be verified against the unit to ensure proper fit.