

TECHNICAL SPECIFICATIONS

S-36T

MODEL NUMBER 141186

DIMENSIONS: 36" x 36" x 72" Gelcoat



STANDARD FEATURES

- One-piece gelcoated fiberglass shower
- 4 inch simulated tile pattern
- Built-in wide corner shelves
- Center drain
- Textured floor

UNIQUE FEATURES

- None

OPTIONS

- Lifter for Pivolok Doors

SYSTEMS

- None

DOOR SELECTION

Combine with AKER's complete shower door offering visit www.akerbymax.com

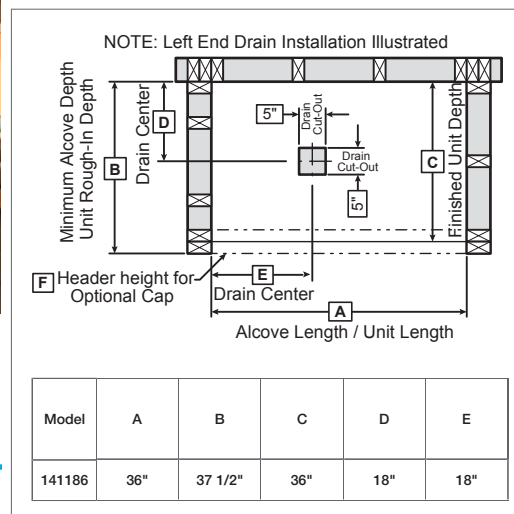
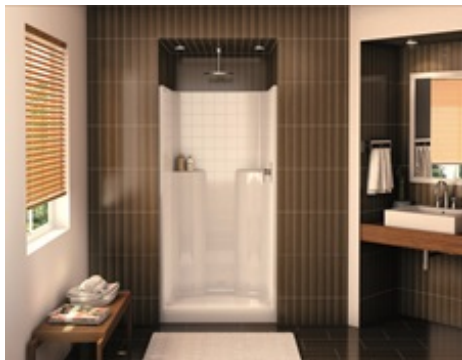

Project :

Contractor :

AKER Representative : Tel :

Date :

CERTIFICATIONS

AKER products adhere to one or more of the following certifications:



TECHNICAL SPECIFICATIONS

S-36T

MODEL NUMBER 141186

TECHNICAL DRAWINGS

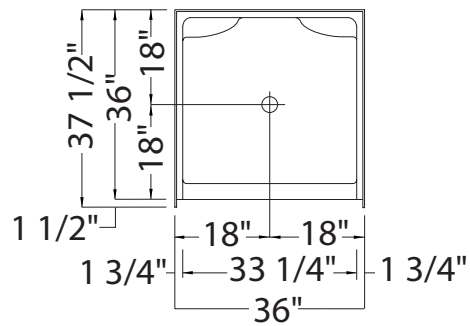
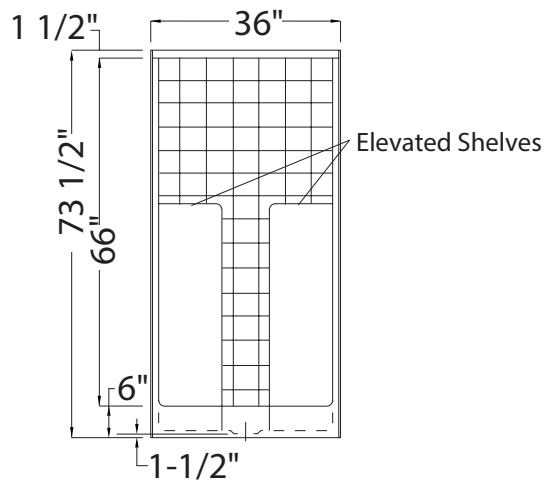

All dimensions are approximate. Structure measurements must be verified against the unit to ensure proper fit.