

TECHNICAL SPECIFICATIONS

GT-6060AP

MODEL NUMBER 141121

DIMENSIONS: 59" x 59" x 24" Gelcoat

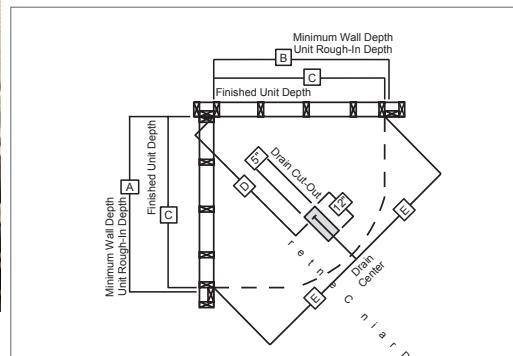

Model	A	B	C	D	E
141121	59"	59"	58"	43 1/4"	41 3/4"

STANDARD FEATURES

- Spacious bathing well
- Integrated tiling flange
- Armrests
- Deck for faucet
- 18 1/2 inch deep sump
- Bottom bathing well: 48 inch L x 35 inch W
- Center drain
- Integrated apron with large access panel
- Textured floor

UNIQUE FEATURES

- Tiling Flange

OPTIONS

- In-line heater (factory-installed)
- Pump position opposite standard position

SYSTEMS

☰ Homestead **DOOR**

SELECTION

Combine with AKER's complete shower door offering visit www.akerbymax.com

CERTIFICATIONS

AKER products adhere to one or more of the following certifications:



Project :

Contractor :

AKER Representative : Tel :

Date :

TECHNICAL SPECIFICATIONS

GT-6060AP

MODEL NUMBER 141121

TECHNICAL DRAWINGS

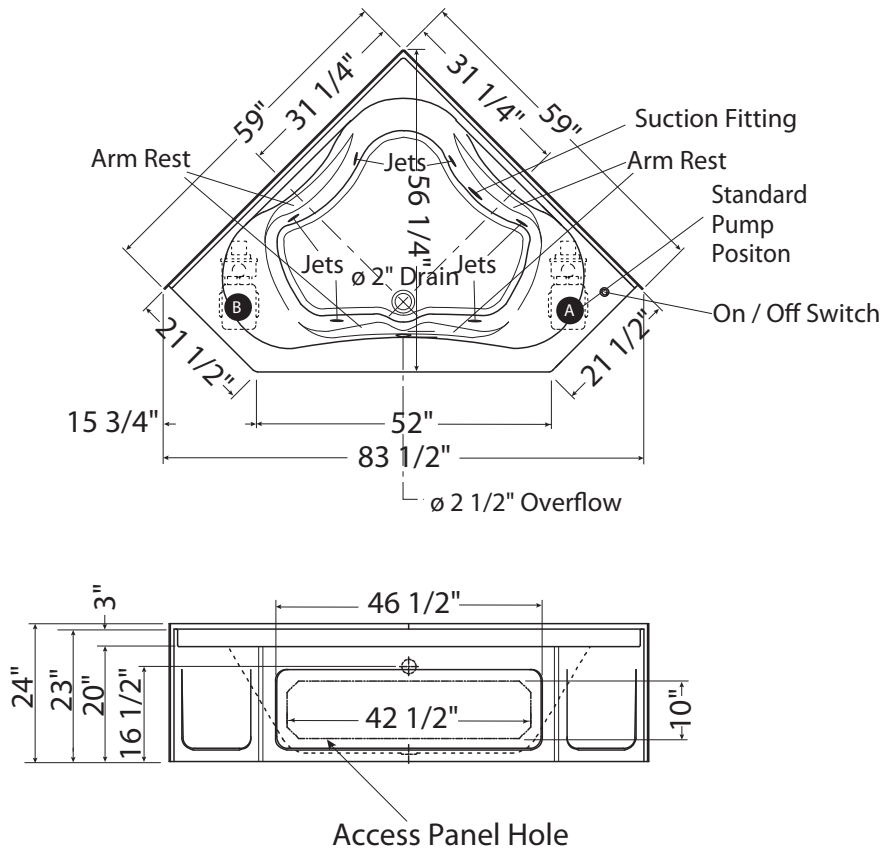

6-jet Homestead System GT-6060AP / HMS (illustrated)