

TECHNICAL SPECIFICATIONS

TO-3060 - Job pack of 12 bathtubs

MODEL NUMBER 141356

DIMENSIONS: 60" x 30 1/2" x 16 3/4" - 17 3/4" Gelcoat



STANDARD FEATURES

- Meets FHA accessibility requirements
- Integrated tiling flange
- 2 3/4 in. Above-the-Floor Rough available
- 14 1/4" deep sump
- Bottom bathing well : 45" L x 19 1/4" W
- Textured floor
- Right or left drain
- Alcove installation
- Job pack of 12 bathtubs
- Job pack of 12 AFR bathtubs available

UNIQUE FEATURES

- Above-the-Floor Rough (AFR)
- Tiling Flange

OPTIONS

- None

SYSTEMS

- None

DOOR SELECTION

Combine with AKER's complete shower door offering visit www.akerbymax.com

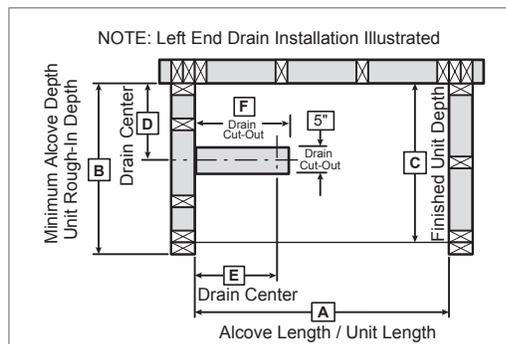

Model	A	B	C	D	E	F
141078	60"	32"	30 1/2"	13 1/2"	8"	11"

Project :

Contractor :

AKER Representative : Tel :

Date :

CERTIFICATIONS

AKER products adhere to one or more of the following certifications:



TECHNICAL SPECIFICATIONS

TO-3060 - Job pack of 12 bathtubs

MODEL NUMBER 141356

TECHNICAL DRAWINGS

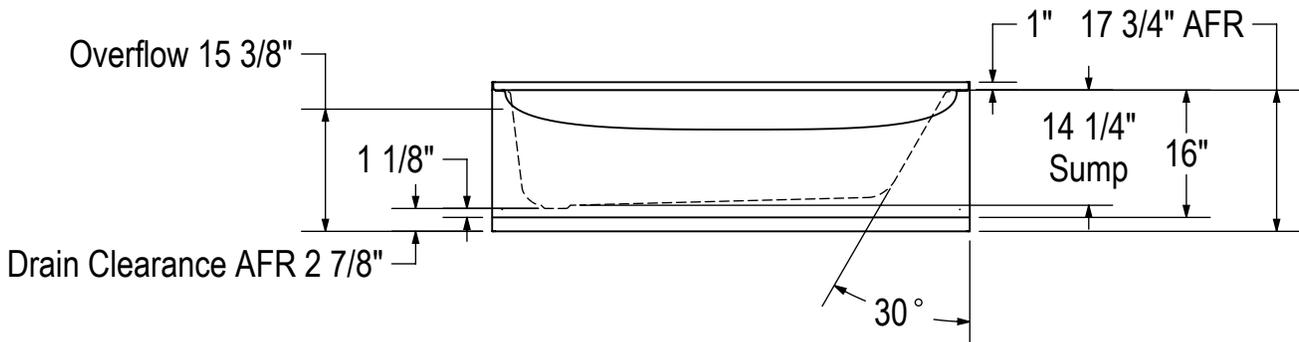
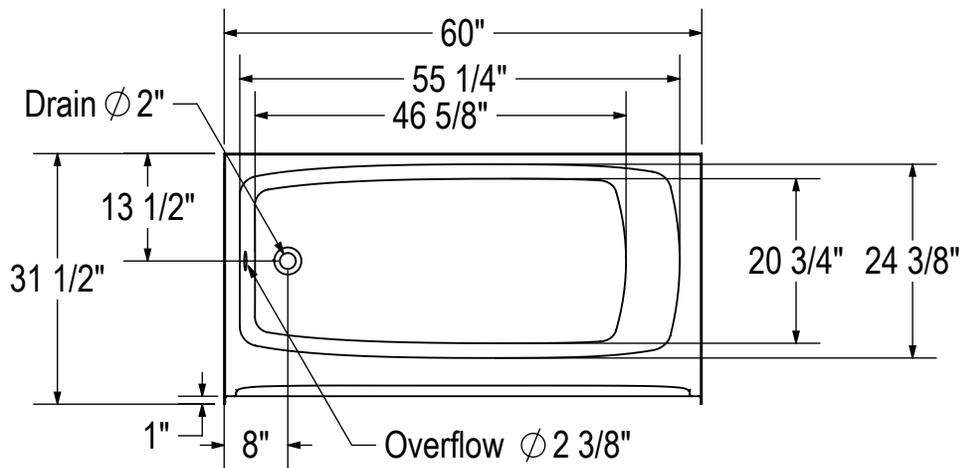

All dimensions are approximate. Structure measurements must be verified against the unit to ensure proper fit.