

FHA 5038 SH	141478
FHA 6038 SH	141523

Read carefully before proceeding. TO BE KEPT BY THE END USER.
Keep the serial number for the unit

PLEASE READ INSTRUCTIONS CAREFULLY BEFORE PROCEEDING

Before starting

Upon reception, check if your shower is in good condition and make sure that all parts are included. If you have a problem, please contact immediately your distributor.

Required equipment

- Level
- Electric drill
- Silicone
- Wood shims
- Cement or similar composite material
- Measuring tape
- #8 x 1" wood screws
- Safety goggles
- Phillips screwdriver
- Pencil
- Square



A two person installation is recommended.

WARNING:



For optimum operation, it is important that the unit be installed perfectly on a leveled floor. Handle metal parts with care. During installation, protect shower floor with the cardboard packaging. This will prevent damaging the finish.

DO NOT BUILD THE SURROUNDING STRUCTURE BEFORE RECEIVING YOUR UNIT. Structure measurements should be verified against the unit to ensure a proper fit.

Grab bars and seats must be installed before unit installation.

Consult local building codes to make sure the installation complies with standards.

MAAX is not responsible for problems caused by installations that were not conducted in compliance with the directives in this guide.

Because of the possible water leaks between the lip of the shower and the curtain, MAAX RECOMMENDS THE INSTALLATION OF A FLOOR DRAIN OUTSIDE THE UNIT, in rooms where the aforementioned units will be installed.

STEP 1 FRAMING

INSTALLATION

A sturdy frame is required to ensure stability of the unit, once installed.

For units equipped with a stainless steel soap dish, make sure that there is no stud behind the soap dish hole.

Construct the alcove in accordance with Fig. A and table dimensions.

NOTE: STRUCTURE MEASUREMENTS MUST BE VERIFIED AGAINST THE UNIT TO ENSURE A PROPER FIT.
All dimensions are expressed in inches and millimeters.



Note: The following measurements are not those of the unit but those required for the installation ($\pm 1/4"$); **for easier installation add 1/4" (6 mm) to dimensions A and B only.**
Note: Some units are available with left-hand or right-hand drain; check the drain position before drilling the floor.

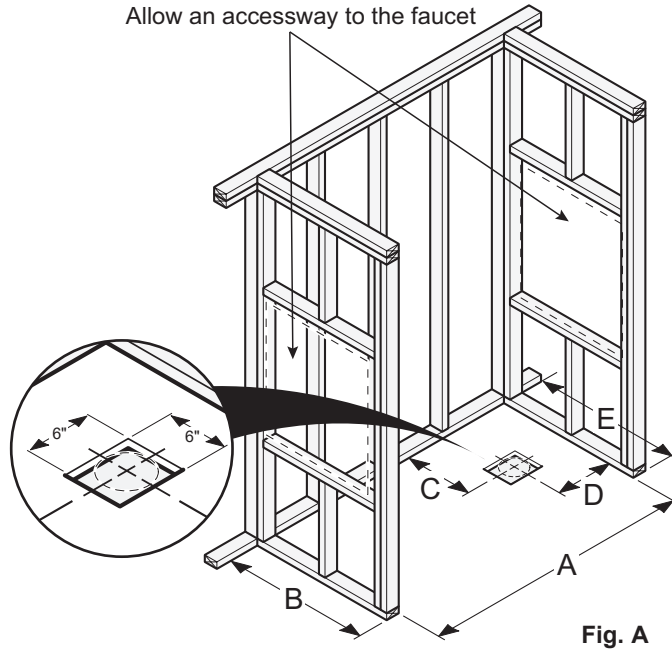

	(50"x38")	(60"x38")
A	50 5/8 1286	60 1524
B	38 5/8 981	38 5/8 981
C	19 1/4 489	19 1/4 489
D	25 1/4 641	30 762
E	38 5/8 981	38 5/8 981

INSTALLATION

STEP 2 UNIT INSTALLATION

- A) Before placing the unit in the alcove, measure the depth. Fig.A.
- B) Using the depth project and trace a line as shown in fig.B.
- C) Place the unit in the alcove, use the traced line as a reference to help in positioning the unit. Verify that everything fits (drain pipe, valve and soap dish). Remove the unit from the alcove. Fig.C.

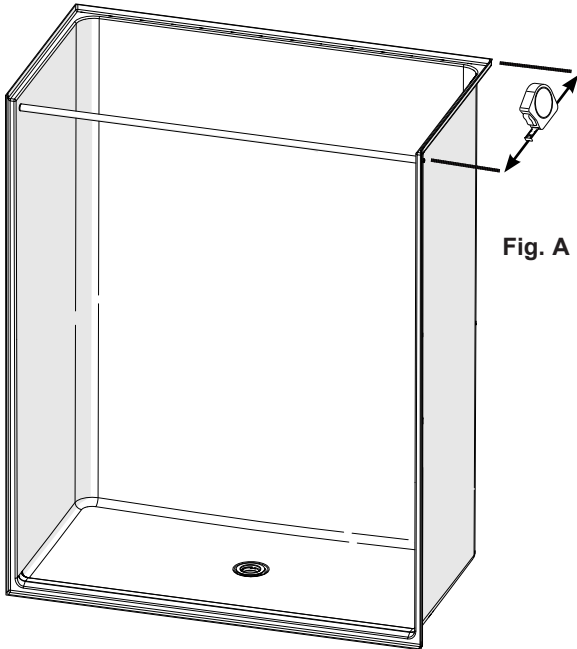

Fig. A

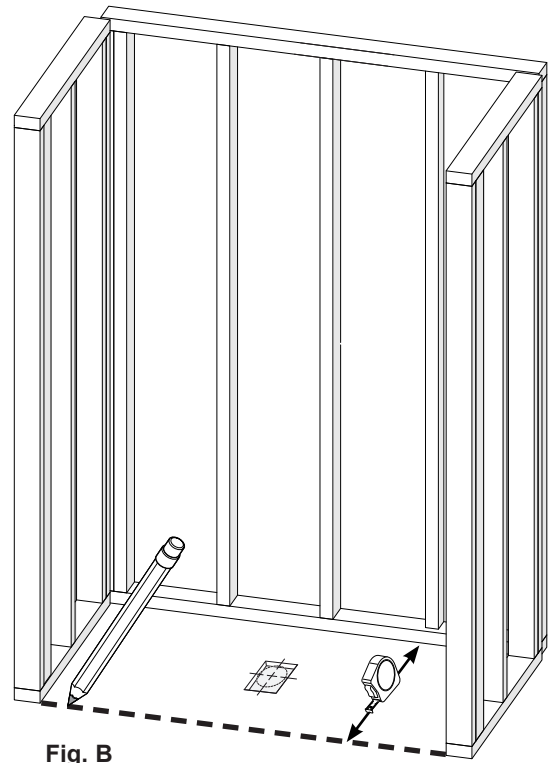

Fig. B

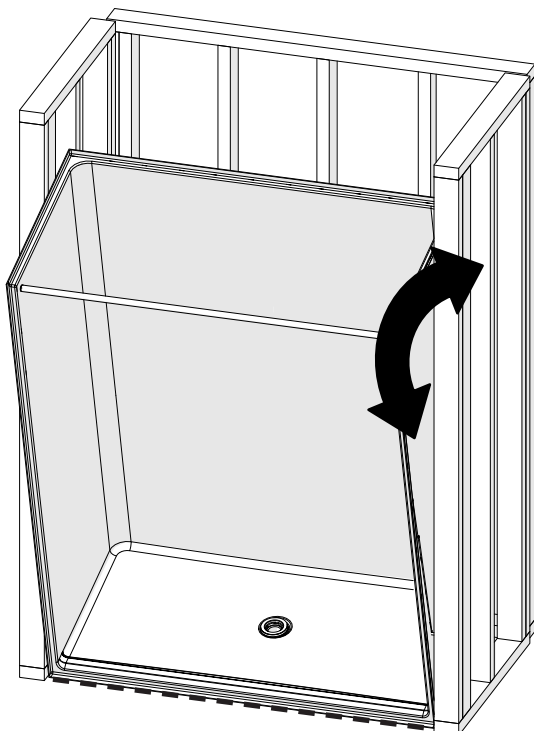

Fig. C

STEP 3

INSTALLATION

UNIT INSTALLATION

- A) Apply a thin layer of mortar. Leave a gap of at least 5 inches around the drain hole as shown. Fig.A.
B) Tip to the front the unit and place it on the previously marked line as shown. Fig.B. Make sure that everything (drain, pipe and valve) is on the right place. Lower the unit slowly into place. Fig.B.
C) Connect plumbing and drainage according to standards. Make sure that joints are waterproof. Fig.C.

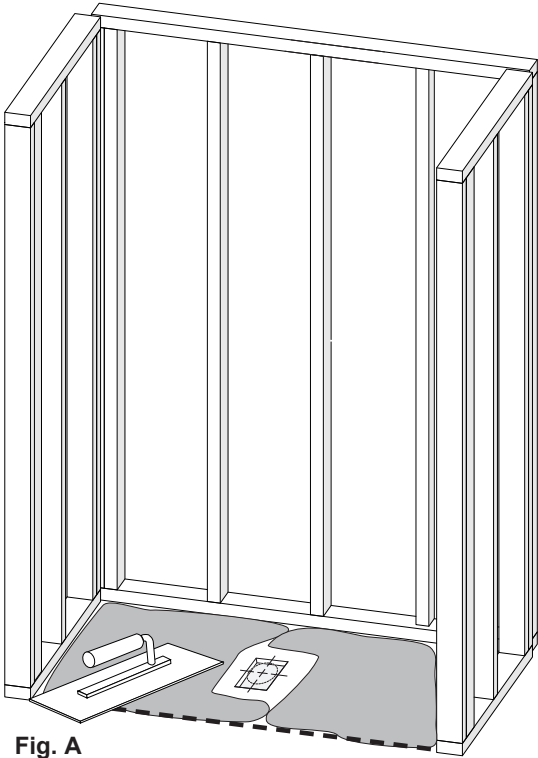

Fig. A

Fig. B

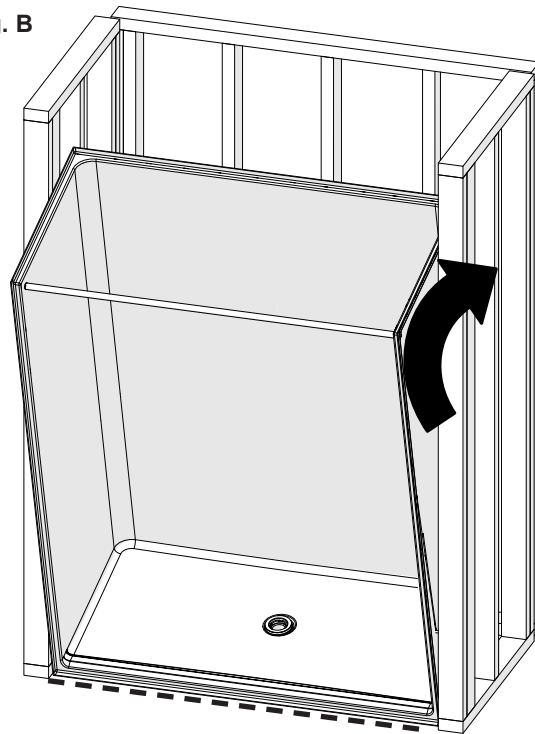
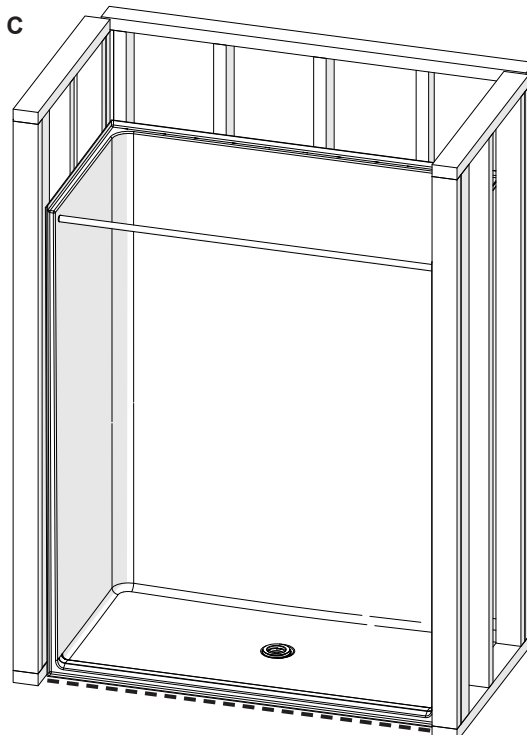

Fig. C



Put cardboard on shower floor to protect the surface during installation.

INSTALLATION

STEP 4

FASTENING OF THE UNIT TO THE FRAME

Level and square the unit.

Fasten unit using #8 screws. Start by fastening a screw in each bottom corner of the unit. Drive in the other screws after checking that the unit is correctly positioned, leveled and squared. Fasten screws into the fastening flange, 8" (20cm) apart along the vertical sides and the floor. For the horizontal sides, fasten a screw in front of each stud.

Use shims as needed to level the unit.

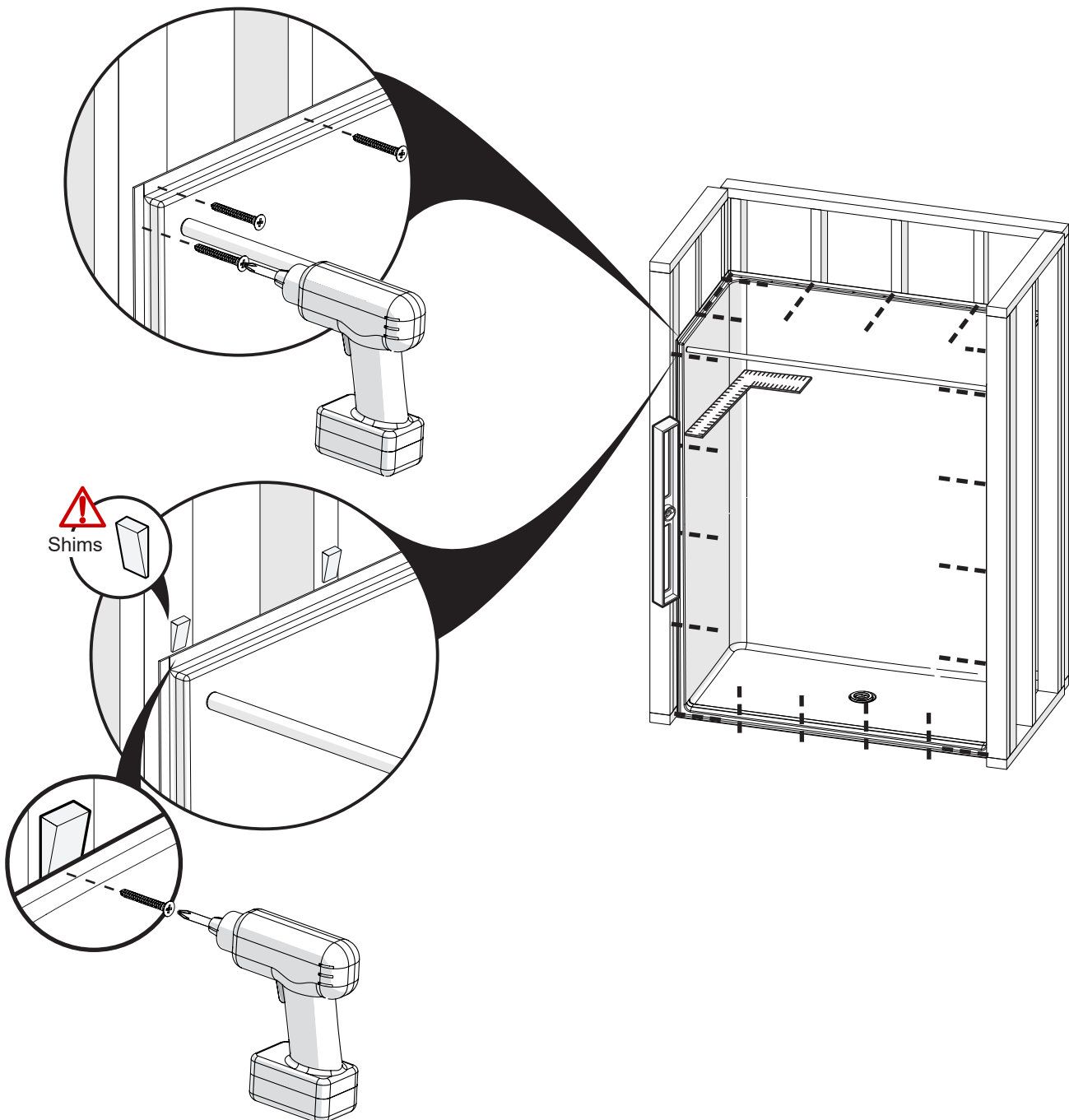

INSTALLATION

STEP 5

FINISH

Finishing panels (plasterboard, ceramic tile, etc.) should completely cover the fastening flange (Fig. A). The joint between the wall panels and the finishing panels can be covered with a joint compound, a plastic stripe, or a tile strip. To prevent water infiltration, apply a bead of silicone between the floor and the threshold of the unit.

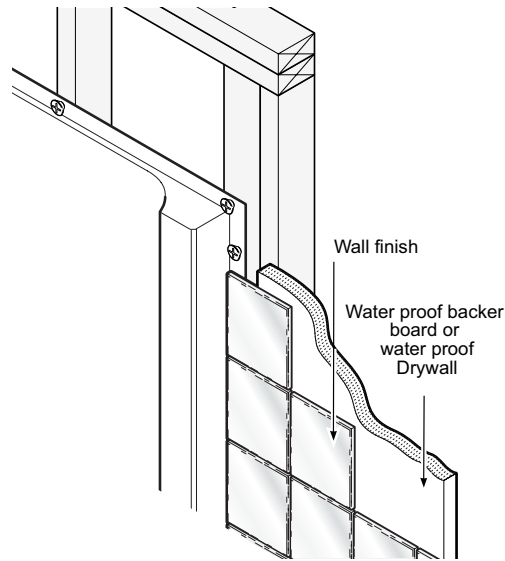

Fig. A

INSTALLATION

LIMITED WARRANTIES

MAAX Bath Inc. (hereafter «MAAX») offers the following express limited warranties on its products. These warranties extend only to the original owner/end-user for personal household use and start from the manufacturing date of the unit. For commercial uses, additional limitations apply.

Maax warrants **AcryIX units** to be free from defects in workmanship and materials under normal use and service for Lifetime Limited in Residential use and for a period of thirty (30) years in Commercial use, from the initial date of purchase by the owner/end-user, contractor or builder from an authorized dealer.

MAAX warrants **fiberglass units** to be free from defects in workmanship and materials under normal use and service for a period of five (5) years from the initial date of purchase by the owner/end-user, contractor or builder from an authorized dealer.

Any product reported to the authorized dealer or to MAAX as being defective within the warranty period will be repaired or replaced (with a product of equal value) at the option of MAAX. Costs for freight associated with shipping of replacement product/parts might be charged to customer. In no event will MAAX be liable for the cost of repair or replacement of any installation materials, including but not limited to, tiles, marble, etc. This warranty extends to the original owner/end-user and is not transferable to a subsequent owner.

Neither the distributor, authorized MAAX dealer nor any other person has been authorized to make any affirmation, representation or warranty other than those contained in this warranty; any affirmation, representation or warranty other than those contained in this warranty shall not be enforceable against MAAX or any other person. MAAX reserves the right to modify this warranty at any time, it being understood that such modification will not alter the warranty conditions applicable at the time of the sale of the products in question.

Limitations

This warranty shall not apply following incorrect operating procedures, breakage or damages caused by normal wear and tear, fault, carelessness, abuse, misuse, misapplication, improper maintenance, alteration or modification of the unit, as well as chemical or natural corrosion, accident, fire, flood, act of God or any other casualty. This warranty shall not apply to stain or malfunction caused by ferrous water, hard water or salty water.

The owner/end-user of the product covered by this warranty is entirely responsible for its proper installation and electrical wiring. This warranty is void if unit is not tested prior to final enclosure as per the installation instructions. MAAX neither installs nor supervises the installation, nor hires a contractor for this purpose, and consequently cannot be held responsible for any defect, breakage or damage caused thereby or resulting thereof, either directly or indirectly. The owner/end-user must provide access to the components of the product as described in the installation guide, so that MAAX can execute the warranty specified herein. If such access is not available, all expenses to provide said access will be the responsibility of the owner/end-user.

This warranty does not apply to products or equipment not installed or operated in accordance with instructions supplied by MAAX and all applicable rules, regulations and legislation pertaining to such installations.

MAAX strongly recommends that its products-for example, but without limitation, shower doors and other items-be installed by professionals with experience in bathroom products. Installation of shower doors by an inexperienced person may result in glass breakage and, consequently, cause personal injury or death. MAAX is not liable for any costs, damages or claims resulting from the purchase of products that do not fit through openings or existing structures. MAAX is not liable for any costs, damages or claims resulting from defects that could have been discovered, repaired or avoided by inspection and testing prior to installation.

MAAX is not liable for personal injuries or death to any person or for any direct, special, incidental or consequential damage, loss of use, loss of time, loss of profits, inconvenience, incidental expenses, labor or material charges, or any other costs resulting from the use of its products or pertaining to the application of the present warranty, or resulting from the removal or replacement of any product or element or part covered by this warranty.

EXCEPT AS OTHERWISE PROVIDED ABOVE, MAAX MAKES NO WARRANTIES, EXPRESS OR IMPLIED, INCLUDING WARRANTIES OF MERCHANTABILITY AND FITNESS FOR A PARTICULAR PURPOSE OR COMPLIANCE WITH ANY CODE.

In any case, MAAX cannot be liable for any amount over and above the purchase price paid for the product by the owner/end-user, contractor or builder. This warranty gives the owner/end-user specific legal rights. The owner/end-user may also have other rights which vary from one state and/or province to another.

Commercial Limitations

In addition to the above conditions and limitations, the warranty period for products installed for commercial applications or used in commercial ventures is of one (1) year from the initial date of purchase by the owner/end-user, contractor or builder from an authorized dealer. If the product is sold by MAAX as a display, MAAX standard warranty applies.

Warranty service

In order to obtain service provided under this warranty during regular business hours, contact the dealer or distributor who sold the unit, or MAAX directly.

MAAX will provide the warranty service described above when the following conditions have been met: (1) the failure is of the nature or type covered by the warranty; (2) the user has informed an authorized MAAX Agent or Warranty Service Department representative, of the nature of the problem during the warranty period; (3) conclusive evidence (e.g., serial number or proof of purchase) is provided to the foregoing by the user proving that the failure occurred or was discovered within the warranty period; and (4) an authorized independent service person or company representative has been permitted to inspect the product during regular business hours within a reasonable time after the problem was reported by the user.

MAAX's warranty obligation shall be discharged upon tender of replacement or repair. The purchaser refusal to accept the tender terminates MAAX's warranty obligation.

MAAX products are certified by one or more of the following certification agencies: CSA, UL, IAPMO, ULI, INTERTEK (ETL), WARNOCK HERSEY and SGS US TESTING. Certain models are pending certification approval. Certification may be ended by MAAX or certification agencies without notice.

AKER, MAAX are registered trademarks of MAAX Bath Inc.

After Sales Service

718 Mid-Atlantic Parkway
Martinsburg, WV 25401

Phone: 800-962-2537 • 304-263-2525

Fax: 304-263-2379

www.akerbymaax.com