

GUIDELINES
FOR UNIT
INSTALLATION

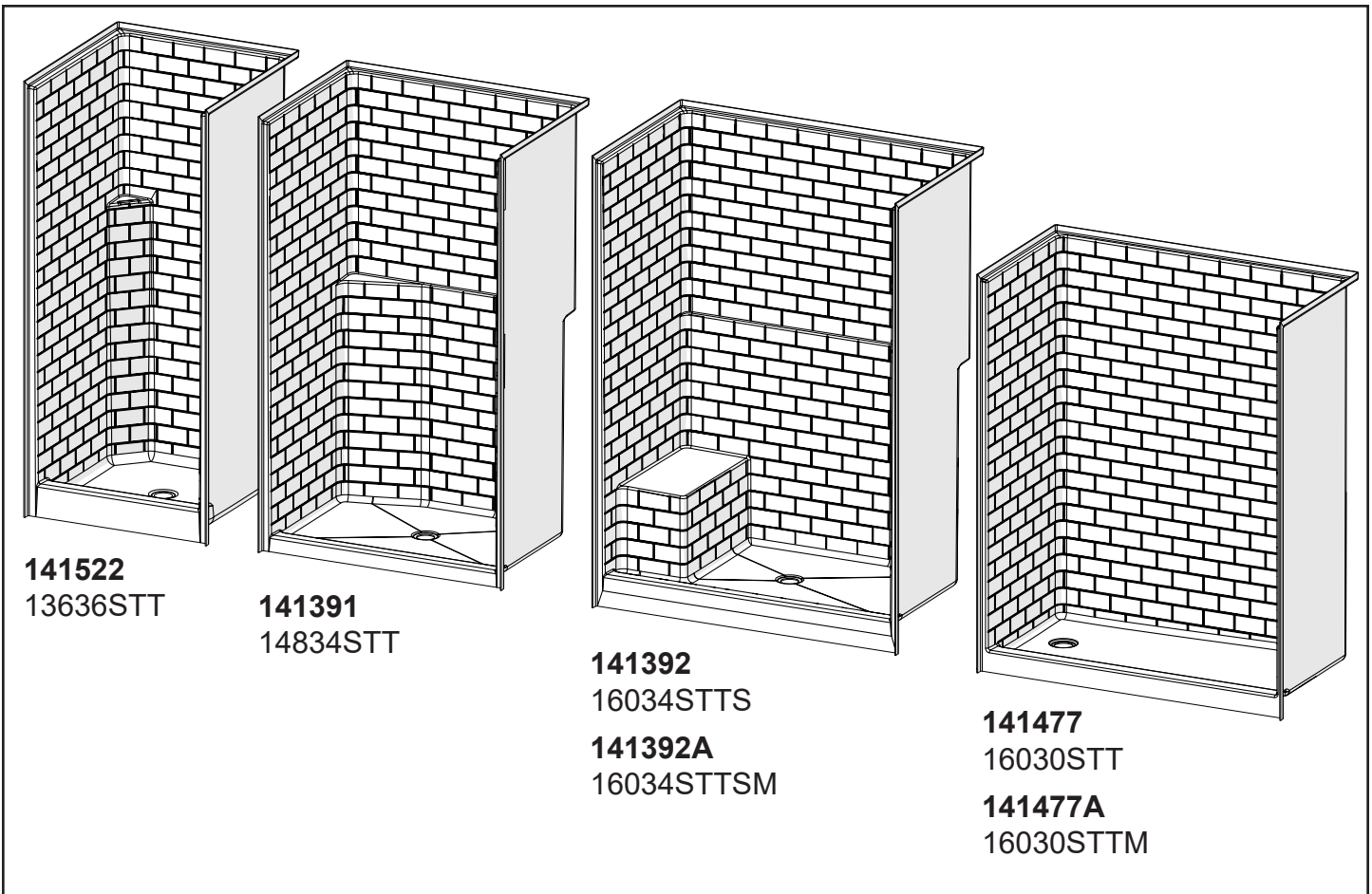

These guidelines are recommended by Maax Bath Inc. (hereafter "MAAX") for the proper installation of their product. A careful review of these procedures (and any referenced publications) before starting is important in avoiding unnecessary problems resulting in an improper assembly or installation.

NOTE: All drawings in this publication are typical, and may appear different than the actual items being installed. In addition, optional items may be shown on the units which may not have been ordered on the unit being installed.

The Aker by Maax bathware line of products does not require additional support under the unit(s) during the installation process. Additional support can be installed at the discretion of the individual installing the unit. Exceptions to this statement occur when the individual using the unit exceeds 300 pounds.

In that situation(s), Aker by MAAX recommends that additional support be provided under the unit.

Special Notes to Installer

- *It is the sole responsibility of the installer to determine, prior to the installation, the requirements necessary for compliance with all codes involving the unit or the installation!
- *All paperwork packaged with the unit and any associated options or accessories should be saved and presented to the homeowner upon completion of the installation!
- *All published unit dimensions are for reference only. **Any critical dimensions required for installation should be taken directly from the unit being installed!**
- *Any independent changes made to the unit (or to any options and accessories supplied with the unit) beyond those required for normal installation can void all warranties! (Refer to *warranties* for further information.)

Inspection Guidelines

A careful check of the unit should be conducted upon receipt. Notify your supplier immediately if any questions or problems are encountered during this process.

DO NOT INSTALL ANY UNIT WITHOUT FIRST ADDRESSING QUESTIONS WHICH ARISE DURING THE INSPECTION!

Basic Module Check

- ✓ Check that the unit drain corresponds to the bathroom drain location.
- ✓ Check for unit surface damage.
- ✓ Check unit color for coordination to other bathroom fixtures.
- ✓ Check for proper options and accessories.

Options/Accessories Check

An individual check list is included with the assembly and installation guidelines of factory authorized options. Refer to listed publications for further information before continuing.

Figure 1a - Unit Data and Dimensional Guidelines (Tolerance: +0/ -3 /8 inch)

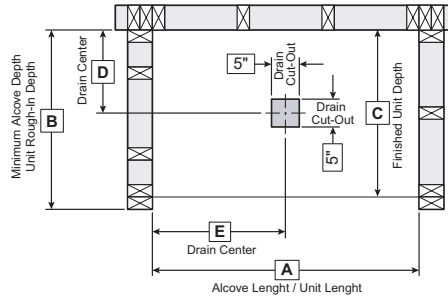
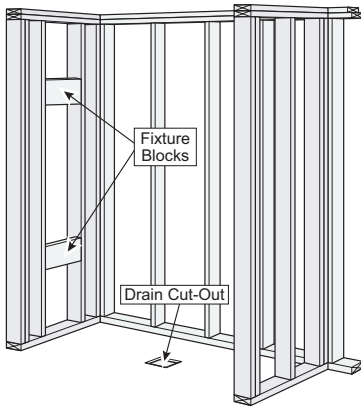

MODEL	A	B	C	D	E
141391 / 14834STT	48 1/8"	35 1/4"	34"	17"	24"
141392 / 16034STTS	60 1/8"	35 1/4"	34"	17"	30"
141392A / 16034STTSM	60 1/8"	35 1/4"	34"	17"	30"
141477 / 16030STT	60 1/8"	31 1/4"	30"	13 7/8"	8 1/2"
141477A / 16030STTM	60 1/8"	31 1/4"	30"	13 7/8"	8 1/2"
141522 / 13636STT	36 1/8"	37 1/4"	36"	18"	18"

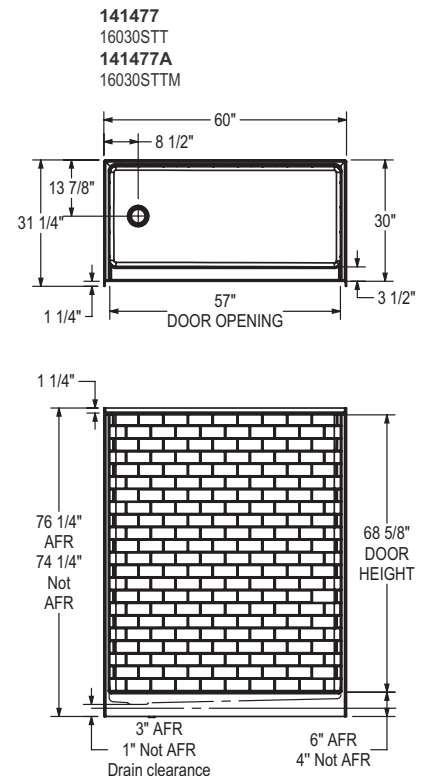
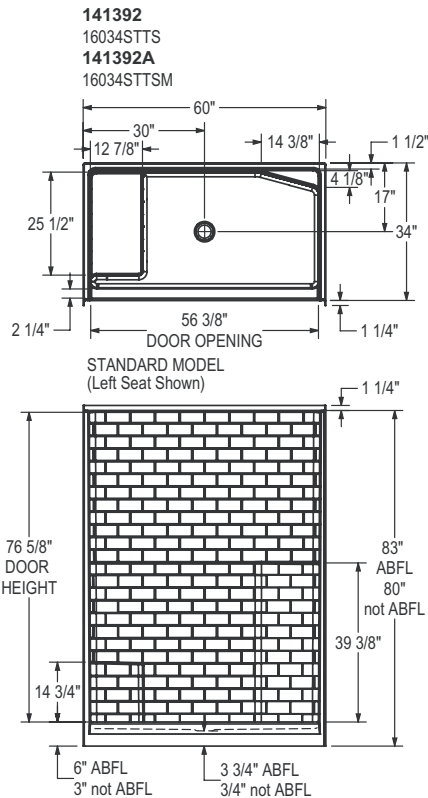
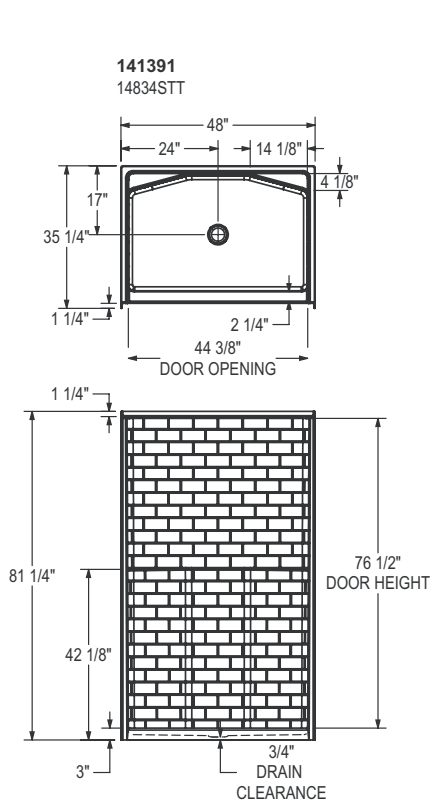
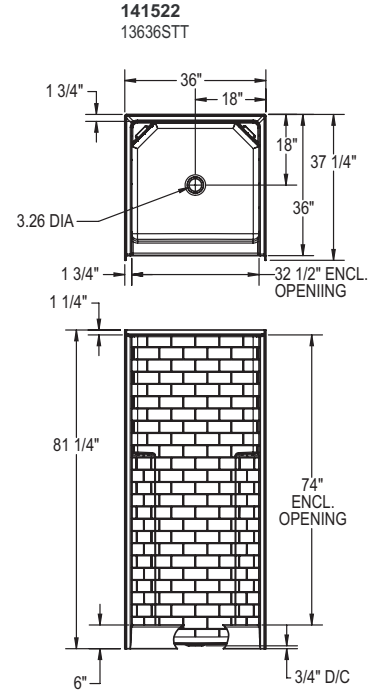

Framing Requirements

Due to individual site variations, exact guidelines for every situation cannot be supplied. The recommended framing and dimensional requirements shown are for a typical application and may vary, depending on site requirements.

The unit framing dimensions shown in Figure 1a are from the surfaces where the unit will be attached. This surface can be bare studding, dry wall or other suitable underlayment material. **It is important that the floor and all framing be square and level.** Framing should be done using accepted materials and construction techniques, in accordance with all applicable codes.

An optional unit cap is available for selected shower models, which will require the construction of a header for proper unit installation. The header is only required for units using a cap.

WARNING!
IF AN OPTIONAL UNIT CAP IS USED,
THE CAP MUST BE INSTALLED ON THE
UNIT BEFORE IT IS PLACED IN THE
ALCOVE!

Installation Procedure

With the unit positioned in the framed area, several details must be checked prior to securing the unit in place. (Figures 2a, 2b)

- ✓ Confirm dam is flush on the floor.
- ✓ Confirm drain alignment.
- ✓ Confirm the unit is level along the top of each side wall and across dam area.
- ✓ Confirm each front inside wall surface is plumb (This is critical for the proper installation of an enclosure).
- ✓ Confirm the unit is square in the framed area.

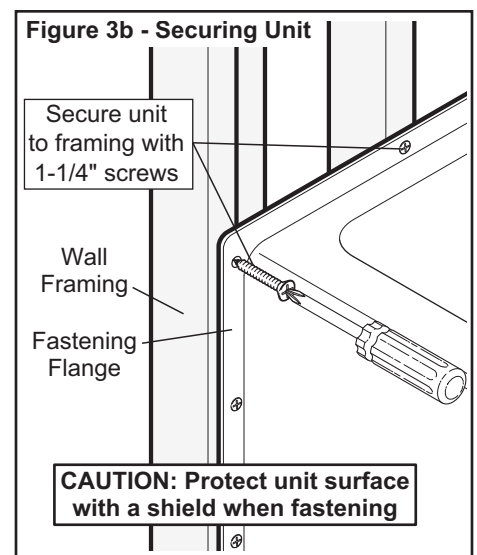
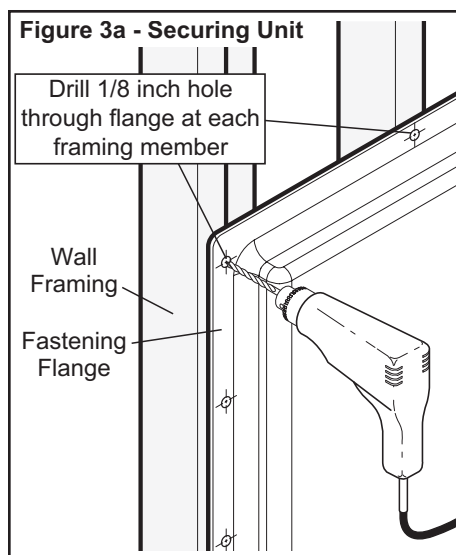
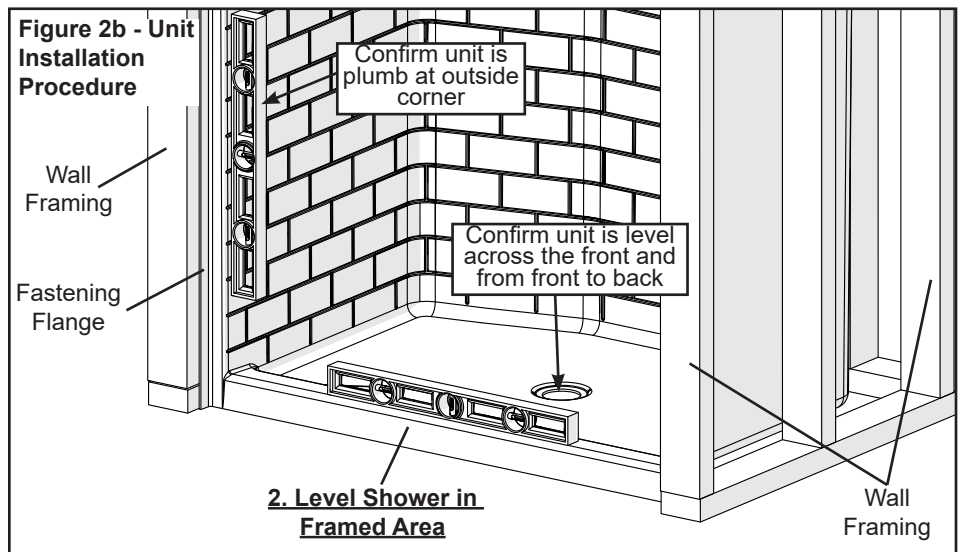
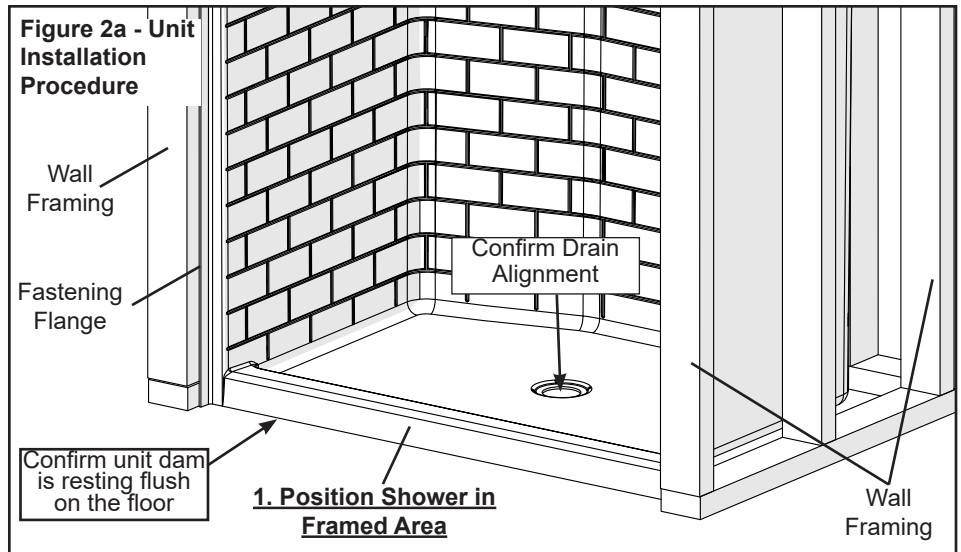

The unit must also be positioned square in the alcove framework. The use of shim or filler material behind the fastening flange at each framing member may be required to maintain the unit in the proper position.

After the unit is confirmed level and square in the alcove, drill a 1/8 inch hole through the fastening flange at each framing member and every 8 inches along the front fastening flanges. Secure the unit in place across the back wall first, followed by the flanges at each end and along the front flanges, using 1-1/4 inch screws or other appropriate fasteners. Continuously check to confirm the unit remains square within the alcove as it is being secured. (Figures 3a & 3b)

WARNING!
THE UNIT BOTTOM SHOULD BE CLEAR OF ALL POTENTIALLY DAMAGING DEBRIS AND THE SURFACE PROTECTED BEFORE STEPPING INSIDE.

CAUTION: It is advisable to protect the unit surface with a thin plywood or cardboard shield while fastening the flange to the framing.

Water Supply and Drain Connections
Refer to, and follow, the assembly and installation instructions provided with the supply valves and drain system. **Carefully check all fittings and connections for leaks.**

Finishing Guidelines
Furring strips or filler material may be required over the framing to ensure the underlayment will lie flush over the fastening flanges. A water resistant underlayment is recommended on areas surrounding the unit. Stop the underlayment 1/16 to 1/8 inch from the unit surface, and fill the space with a continuous bead of waterproof sealant.

Carefully fasten the underlayment near the unit to avoid damaging the unit surface. Seal the seams and edges of the underlayment, as required, and install the finish material to specifications. (Figure 4)

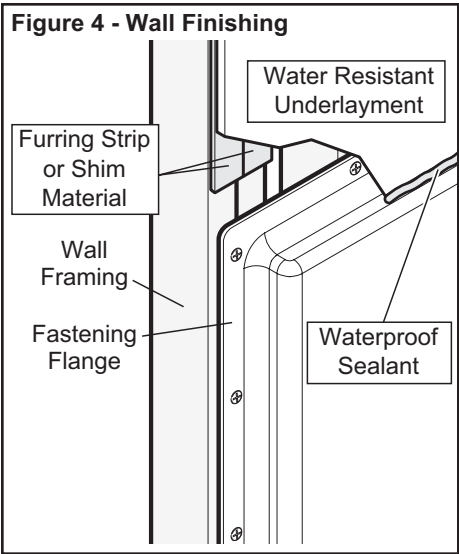

Unit Surface Care
WARNING!
NEVER USE ABRASIVE MATERIALS NOR ABRASIVE CLEANERS ON THE UNIT SURFACE!

EXTREME CAUTION is urged regarding the use of any cleaner, acid or solvent on the unit surface.

READ, AND FOLLOW ALL PACKAGE LABELS AND INSTRUCTIONS!

Through routine use, the unit surface can collect residues from soap, bath additives and natural body oils. Additional deposits can also collect from minerals or particles found in the water.

After each use, wipe the excess water from the unit. This practice will reduce the build-up of deposits and help maintain the natural unit lustre.

Following a thorough surface cleaning, an application of quality automotive wax will help reduce major accumulations. The actual schedule for cleaning, and waxing, will depend on unit usage and water quality.

WARNING!
AVOID APPLYING WAX TO THE UNIT BOTTOM!

- Routine Cleaning: Mild, non-abrasive cleaner specifically formulated for gelcoat and acrylic surfaces recommended. (Rinse surface thoroughly.)
- Heavy Soap Deposits: Liquid ammonia household cleaner, applied full strength. (Rinse surface thoroughly.)
- Stubborn Stains: Liquid household cleaner or hydrogen peroxide, applied full strength. Place a saturated clean rag directly on stain and let stand several hours. (Rinse surface thoroughly.)

For extreme cases, buff area with white automotive polishing compound until stain disappears, and apply a quality automotive wax to surface.

- Hard Water Scales: Liquid scale remover or white vinegar, applied full strength. (Rinse surface thoroughly.)
- Mold/Mildew: Liquid mildew remover or baking soda and water paste. Apply paste and allow to fizz several minutes. (Rinse surface thoroughly.)
- Construction Adhesive: Soften adhesive with hand held dryer and peel off adhesive. (Caution is advised when using any electrical device near water.)

For stubborn cases, apply rubbing alcohol or nail polish remover, full strength, to adhesive. (Rinse surface thoroughly.)

WARNING!
BATH MATS OR OTHER ITEMS WHICH ARE HELD IN PLACE USING SUCTION AGAINST THE UNIT SURFACE MUST BE REMOVED FROM THE FLOOR OF THE UNIT AFTER EACH USE.

OVER A PROLONGED PERIOD, FAILURE TO REMOVE THESE TYPES OF ITEMS FROM THE BOTTOM OF THE UNIT CAN RESULT IN SURFACE DAMAGE.





LIMITED WARRANTY

Maax Bath Inc. (hereafter «Maax») offers the following express limited warranty on each of its products. This warranty extends only to the original owner/end-user for personal household use. For commercial uses, additional limitations apply.

Maax warrants **AcrylX units** to be free from defects in workmanship and materials under normal use and service for Lifetime Limited in Residential use and for a period of thirty (30) years in Commercial use, from the initial date of purchase by the owner/end-user, contractor or builder from an authorized dealer.

Maax warrants **fiberglass units** to be free from defects in workmanship and materials under normal use and service for a period of five (5) years from the initial date of purchase by the owner/end-user, contractor or builder from an authorized dealer.

Any product reported to the authorized dealer or to Maax as being defective within the warranty period will be repaired or replaced (with a product of equal value) at the option of Maax. In no event will Maax be liable for the cost of repair or replacement of any installation materials, including but not limited to, tiles, marble, etc. This warranty extends to the original owner/end-user and is not transferable to a subsequent owner.

Neither the distributor, authorized Maax dealer nor any other person has been authorized to make any affirmation, representation or warranty other than those contained in this warranty; any affirmation, representation or warranty other than those contained in this warranty shall not be enforceable against Maax or any other person.

Maax reserves the right to modify this warranty at any time, it being understood that such modification will not alter the warranty conditions applicable at the time of the sale of the products in question.

Limitations

This warranty shall not apply following incorrect operating procedures, breakage or damages caused by fault, carelessness, abuse, misuse, misapplication, improper maintenance, alteration or modification of the unit, as well as chemical or natural corrosion, accident, fire, flood, act of God or any other casualty. This warranty shall not apply to stain or malfunction caused by ferrous water, hard water or salty water.

The owner/end-user of the product covered by this warranty is entirely responsible for its proper installation and electrical wiring. Maax neither installs nor supervises the installation, nor hires a contractor for this purpose, and consequently cannot be held responsible for any defect, breakage or damage caused thereby or resulting thereof, either directly or indirectly. The owner/end-user must provide access to the components of the product as described in the installation guide, so that Maax can execute the warranty specified herein.

If such access is not available, all expenses to provide said access will be the responsibility of the owner/end-user.

This warranty does not apply to products or equipment not installed or operated in accordance with instructions supplied by Maax and all applicable rules, regulations and legislation pertaining to such installations.

Maax strongly recommends that its products-for example, but without limitation, shower doors and other items-be installed by professionals with experience in bathroom products. Installation of shower doors by an inexperienced person may result in glass breakage and, consequently, cause personal injury or death.

Maax is not liable for any costs, damages or claims resulting from the purchase of products that do not fit through openings or existing structures. Maax is not liable for any costs, damages or claims resulting from defects that could have been discovered, repaired or avoided by inspection and testing prior to installation.

Maax is not liable for personal injuries or death to any person or for any direct, special, incidental or consequential damage, loss of time, loss of profits, inconvenience, incidental expenses, labor or material charges, or any other costs resulting from the use of the product or equipment or pertaining to the application of the present warranty, or resulting from the removal or replacement of any product or element or part covered by this warranty.

EXCEPT AS OTHERWISE PROVIDED ABOVE, MAAX MAKES NO WARRANTIES, EXPRESS OR IMPLIED, INCLUDING WARRANTIES OF MERCHANTABILITY AND FITNESS FOR A PARTICULAR PURPOSE OR COMPLIANCE WITH ANY CODE.

In any case, Maax cannot be liable for any amount over and above the purchase price paid for the product by the owner/end-user, contractor or builder.

Commercial Limitations

In addition to the above conditions and limitations, the warranty period for products installed for commercial applications or used in commercial ventures is of one (1) year from the initial date of purchase by the owner/end-user, contractor or builder from an authorized dealer for Fiberglass units and thirty (30) for AcrylX units. Maax is not responsible for loss of use or profit under any circumstances.

If the product is used as a display, Maax standard warranty applies and the warranty period begins when the product is placed on display. This warranty gives the owner/end-user specific legal rights. The owner/end-user may also have other rights which vary from one state and/or province to another.

Warranty service

In order to obtain service provided under this warranty during regular business hours, contact the dealer or distributor who sold the unit, or Maax directly. Maax will provide the warranty service described above when the following conditions have been met: (1) the failure is of the nature or type covered by the warranty; (2) the user has informed an authorized Maax Agent or Warranty Service Department representative of the nature of the problem during the warranty period; (3) conclusive evidence (e.g., proof of purchase or installation) is provided to the foregoing by the user proving that the failure occurred or was discovered within the warranty period; and (4) an authorized independent service person or company representative has been permitted to inspect the product during regular business hours within a reasonable time after the problem was reported by the user.

Maax's warranty obligation shall be discharged upon tender of replacement or repair. The purchaser refusal to accept the tender terminates Maax's warranty obligation.

MAAX products are certified by one or more of the following certification agencies: UL, IAPMO, CSA, ULI, INTERTEK / WARNOCK HERSEY. Certain models are pending certification approval. Certification may be ended by MAAX or certification agencies without notice.

AKER and MAAX are registered trademarks of MAAX Bath Inc.

After Sales Service

718 Mid-Atlantic Parkway
Martinsburg, WV 25401

Phone: 1-877-GET-MAAX (1-877-438-6229)

Fax: 304-263-2379

www.akerbymaax.com