

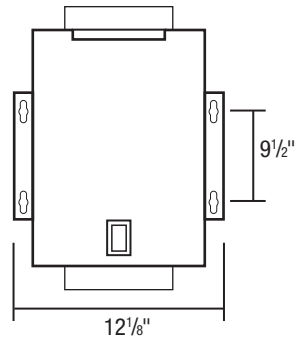

SPECIFICATIONS
MFAS
FRESH AIR SUPPLY FAN

 **80 CFM @ 0.20" SP.**
50 CFM @ 0.20" SP.

- **Blower Wheel**
Balanced polymeric dual inlet blower wheel secured in place using a hex nut.
- **Motor**
Dual Speed, Heavy duty, permanently split capacitor, plug-in, life time lubrication, thermally protected, suitable for continuous operation. Rated 120 volts, 60 hz.
- **Fan Housing**
Insulated 26 gauge galvanized steel housing. Overall dimensions: 17³/₈"H x 8¹/₄"D x 9"W.
- **Duct Collars**
6" round, zinc plated metal collar adapters.
- **Electrical Connections**
1/2" electrical access. Easy wiring access via external wiring compartment cover or internal access plate.
- **Unit Mounting**
Designed to surface mount to a wall or ceiling with the included mounting brackets. Can be mounted onto joists, studs or the housing mounting brackets can be adapted for overhead mounting (hardware not provided).
- **Optional Air Filter**
An optional nominal 8" x 9" x 2" Merv 8 or Merv 13 air filter can be added to the unit (not included).
- **Test Port**
Allows easy air flow measurement with Pitot tube or similar device.

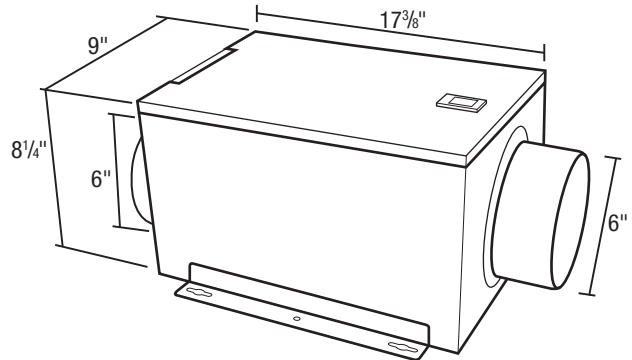

EXPANDED PERFORMANCE										
	<i>Static Pressure (inches of w.g.)</i>							<i>Fan Speed RPM</i>	<i>Maximum Fan Watts</i>	<i>Amps</i>
	0	0.1	0.2	0.3	0.4	0.5	0.6			
Air Flow - CFM (High Speed)	90	85	80	75	69	62	54	1968	82.9	0.8
Air Flow - CFM (Low Speed)	55	53	50	47	43	38	31	1560	42.9	

PROJECT					ARCHITECT				
LOCATION					ENGINEER				
CONTRACTOR					SUBMITTED BY			DATE	
FAN NUMBER	MODEL NUMBER	CFM	IN W.G.	RPM	WATTS	AMPS	SONES	QTY	OPTIONAL EQUIPMENT & REMARKS



U.S.: 820 Lincoln Avenue
West Chester, Pennsylvania 19380-4466
Tel: (610) 692-7400 • 877-304-3785
Fax: (610) 696-8048

Canada:
Brampton, Ontario
Tel: 905-456-2033
Fax: (905) 456-1015