

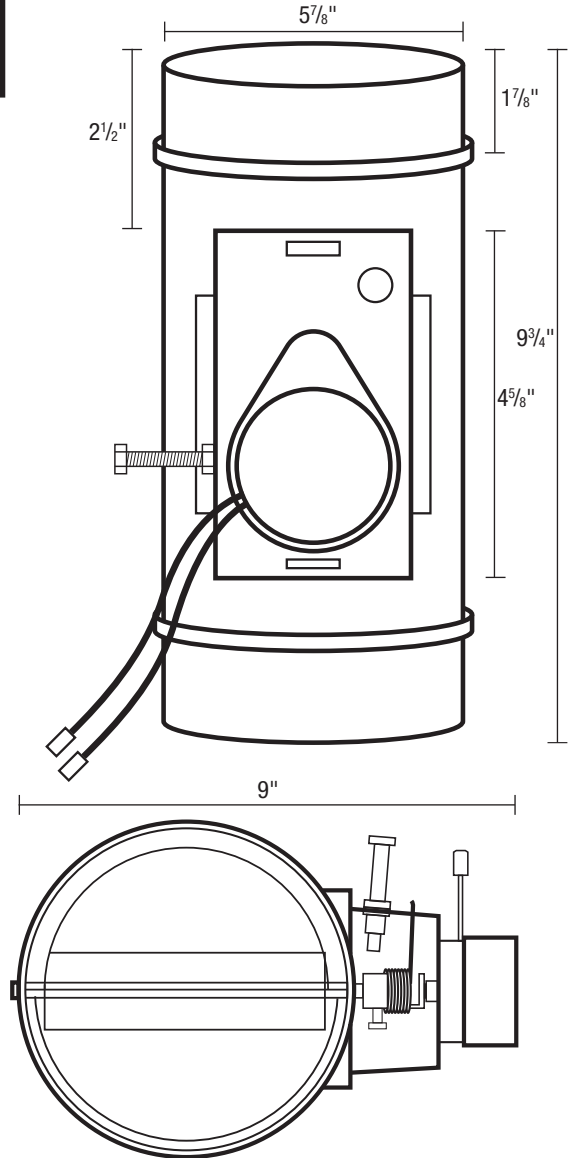

SPECIFICATIONS
MD624
MOTORIZED DAMPER

Motorized Damper

- **Description**
 Motorized fresh air intake damper for usage with Air King QFAM and FAS models.
- **Power**
 Rated voltage: 24VAC, 60HZ
 Rated power: 6 watts
- **Mounting**
 Mounts inline with FAS or QFAM series fresh air machines.
- **Connections**
 Included 24 volt transformer connects to internal receptical in FAS or QFAM unit.
 Lead wires: 22 AWG, 12 inches
- **Construction**
 Galvanized steel
- **Damper**
 Single blade damper. Internal gasket to tightly close off ducting, minimizing air leakage.



PROJECT							ARCHITECT			
LOCATION							ENGINEER			
CONTRACTOR							SUBMITTED BY			DATE
FAN NUMBER	MODEL NUMBER	CFM	IN W.C.	RPM	WATTS	AMPS	SONES	QTY	OPTIONAL EQUIPMENT & REMARKS	



U.S.: 820 Lincoln Avenue
 West Chester, Pennsylvania 19380-4466
 Tel: (610) 692-7400 • 877-304-3785
 Fax: (610) 696-8048

Canada:
 Brampton, Ontario
 Tel: 905-456-2033
 Fax: (905) 456-1015