



**SPECIFICATIONS**  
**LE600**  
**POWER PACK**

**HVI**  
2100  
CERTIFIED

**High Speed 600 CFM/4.0 Sones @ 0.10" SP.**  
**Medium Speed 400 CFM/2.5 Sones @ 0.10" SP.**  
**Low Speed 200 CFM/0.3 Sones @ 0.03" SP.**

**• Dimensions**

Overall bottom projection - 11"  
Height - 11"  
Width - 28" (for 30" canopy)

**• Body**

Galvanized steel body with stainless steel fascia. Install at least 24" above the cooking surface.

**• Blower**

3 speed, thermally protected, permanently lubricated, split capacitor, 120V 60 Hz. with two electronically balanced blower wheels.

**• Lighting**

2 - ENERGY STAR® certified MR16, GU10 base 6.5 watt LED lamps, 500 lumens, JA8 compliant.

**• Ducting**

Vertical ducting: 10" round ducting with all metal model OA10VD outlet adapter and back draft damper.

**• Filters**

Aluminum grease filters (included).

**• Cut Out Opening Size**

Width 26 7/8"  
Depth - 10"

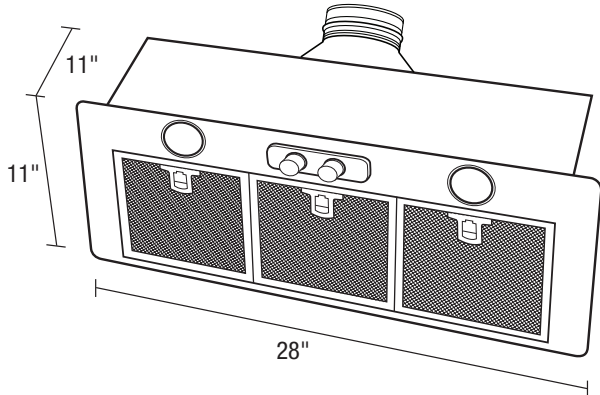

28"



<b>EXPANDED PERFORMANCE</b>										
<i>Air Flow - CFM</i>	<i>Static Pressure (inches of w.g.)</i>						<i>Sones @ .1 SP</i>	<i>Fan Speed RPM</i>	<i>Power Watts</i>	<i>Amps</i>
	<i>0</i>	<i>0.1</i>	<i>0.15</i>	<i>0.25</i>	<i>0.3</i>	<i>0.375</i>				
<b>High Speed</b>	629	600	583	540	516	475	4.0	1491	181	2.0
<b>Medium Speed</b>	415	400	391	371	356	325	2.5	1334	132	2.0
<b>Low Speed</b>	210	167	146	112	93	-	0.3	666	59.5	2.0

<b>PROJECT</b>							<b>ARCHITECT</b>			
<b>LOCATION</b>							<b>ENGINEER</b>			
<b>CONTRACTOR</b>							<b>SUBMITTED BY</b>			<b>DATE</b>
FAN NUMBER	MODEL NUMBER	CFM	IN W.C.	RPM	WATTS	AMPS	SONES	QTY	OPTIONAL EQUIPMENT & REMARKS	



**Air King:** 820 Lincoln Avenue  
West Chester, Pennsylvania 19380-4466  
Tel: (610) 692-7400 • 877-304-3785  
Fax: (610) 696-8048

**Canada:**  
Brampton, Ontario  
Tel: 905-456-2033  
Fax: (905) 456-1015