



SPECIFICATIONS
EVLDH
 VARIABLE AIRFLOW DUAL SPEED
 EXHAUST FAN



HIGHEST AVAILABLE SPEED: 150 CFM/0.6 Sones @ 0.10 SP.
LOWEST AVAILABLE SPEED: 30 CFM/<0.3 Sones @ 0.10" SP.

- Grill**
 White, polymeric grill secured in place with torsion springs; easily removed if necessary, dimensions - 17" x 15 7/8".
- Blower Wheel**
 Balanced polymeric dual inlet blower wheel secured in place using a hex nut.
- Adjustable Capacity Motor**
 8 capacity settings on low speed allow the fan to be set to the required exhaust rate for continuous ventilation. Low speed set points include: 30 40 50 60 70 90 100 & 120 CFM
 High speed rapidly clears the air of moisture, odors or other contaminants. High speed set points include: 80 110 130 Boost
 Quiet 4 Pole motor, suitable for continuous operation, permanently lubricated, 115/120V 60 Hz., 0.30 amps. Ideal for compliance with ASHRAE 62.2, LEED, ENERGY STAR® for Homes, California Title 24 and other programs.
- Humidity Sensor**
 Integrated humidity sensor, adjustable up to 80% RH automatically turns fan to high speed until humidity drops to the desired set point.
- Fan Housing**
 23 gauge galvanized steel housing. Overall dimensions: 12 7/8" x 12 3/4" x 9 7/8".
- Duct Collar**
 6" round, zinc plated metal collar adapter. Gasketed, spring loaded aluminum backdraft damper.
- Electrical Connections**
 0.5" electrical knockouts provided. Easy wiring access via either internal or external wiring compartment cover.
- Lighting**
 Dimmable LED Lamp rated 8.5 Watts 800 Lumens 94 Lumens/Watt, 3000K.
California Title 24 and JA8 compliant.
- Single Pack Shipping Info**
 Box Dim: 20" x 15 7/8" x 11 1/8"
 Shipping Weight: 17 lbs.

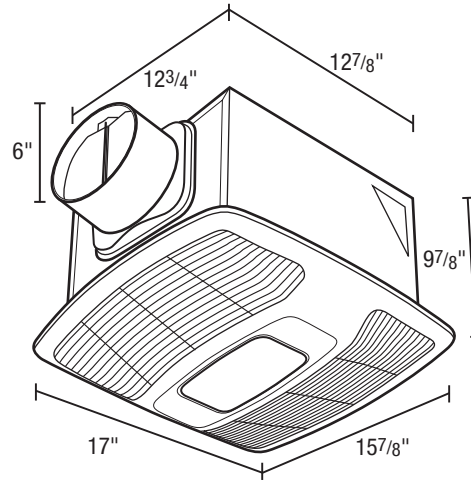

Acceptable for use over tub or shower when installed in a GFCI protected branch circuit.



- Unit Mounting**
 The housing will mount through drywall thickness up to 3/4", with a rough-in opening of 13 1/8" x 13". The housing will mount either between 16" or 24" on center joists, using the 2 supplied housing mounting brackets. The housing mounting brackets can be adapted for overhead mounting (hardware not provided). The unit is provided with an optionally installed ceiling flange to ensure proper building infiltration rates are maintained and that no air leaks occur between the fan housing and ceiling cutout.

SEE REVERSE SIDE FOR STATIC PRESSURE RANGES

PROJECT							ARCHITECT			
LOCATION							ENGINEER			
CONTRACTOR							SUBMITTED BY		DATE	
FAN NUMBER	MODEL NUMBER	CFM	IN W.G.	RPM	WATTS	AMPS	SONES	QTY	OPTIONAL EQUIPMENT & REMARKS	



U.S.: 820 Lincoln Avenue
 West Chester, Pennsylvania 19380-4466
 Tel: (610) 692-7400 • 877-304-3785
 Fax: (610) 696-8048

Canada:
 Brampton, Ontario
 Tel: 905-456-2033
 Fax: (905) 456-1015



SPECIFICATIONS
EVLDH
 VARIABLE AIRFLOW DUAL SPEED
 EXHAUST FAN

ACHIEVABLE STATIC PRESSURES

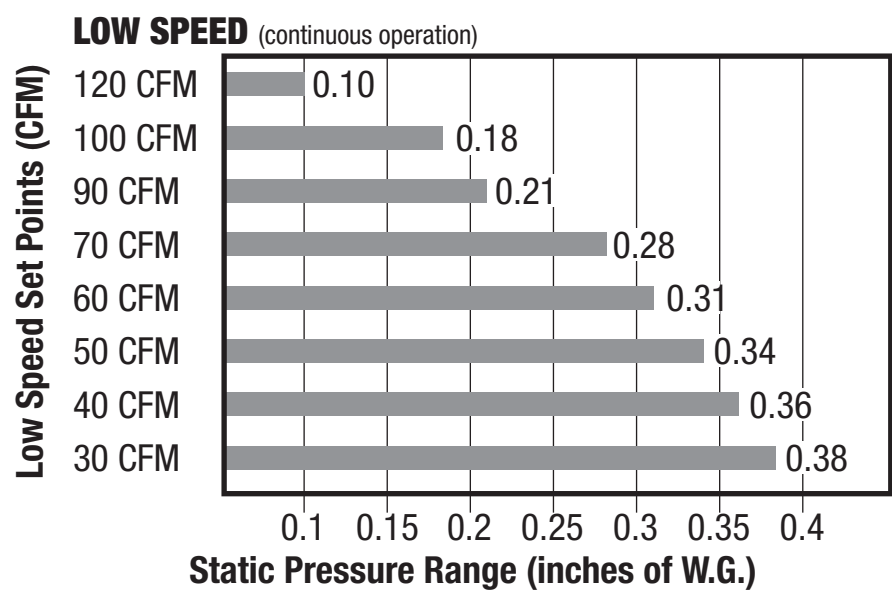
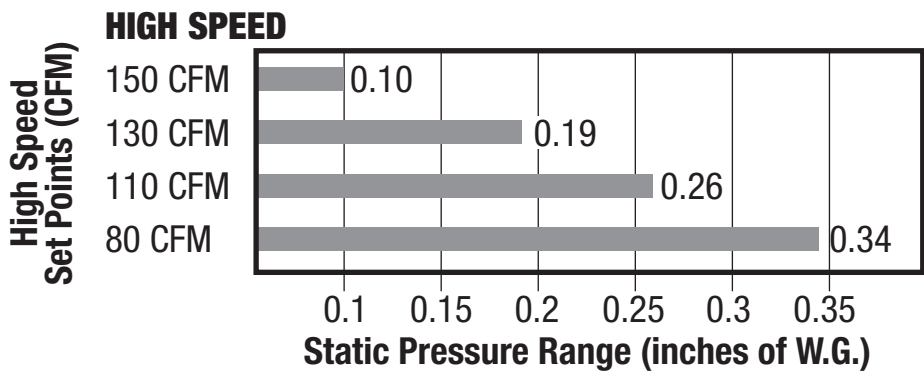

U.S.: 820 Lincoln Avenue
 West Chester, Pennsylvania 19380-4466
 Tel: (610) 692-7400 • 877-304-3785
 Fax: (610) 696-8048

Canada:
 Brampton, Ontario
 Tel: 905-456-2033
 Fax: (905) 456-1015