

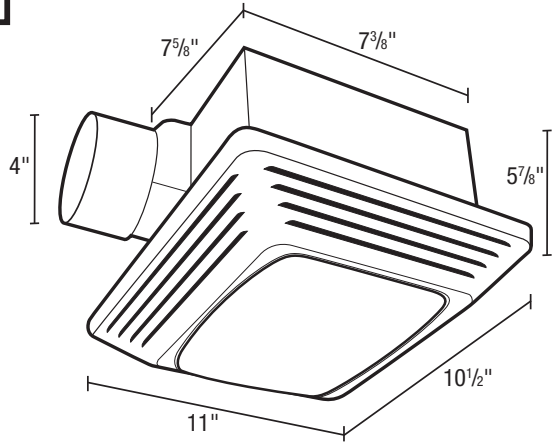

**SPECIFICATIONS**  
**ASLC50**  
EXHAUST FAN WITH LIGHT

**HVI** 2100  
CERTIFIED **50 CFM/4.0 Sones @ 0.10" SP.**

- **Grill**  
White, polymeric grill secured in place via screw mounting through the light housing, dimensions - 11" x 10 1/2".
- **Light Lens**  
High impact polycarbonate lens, secured in position using integral tabs: easily removed if necessary.
- **Light Housing**  
Heavy gauge cold rolled steel c/w baked enamel finish; locks in place on the grill via two integral tabs.
- **Blower Wheel**  
One piece polymeric wheel, 4 1/2" diameter, 1" wide, with 10 fins.
- **Motor**  
PSC, plug-in, 4 pole motor, life time lubrication, thermally protected. Rated 120 volts, 60 hz..
- **Fan Housing**  
23 ga. Galvanized metal housing, dimensions 7 3/8" x 7 5/8" x 5 7/8", double metal thickness mounting tabs.
- **Duct Collar**  
Plastic collar for 4" duct connection, comes complete with built in non-metallic back draft damper for quiet operation.
- **Ventilating Area**  
For bathrooms up to 45 sq. ft. for other rooms up to 60 sq. ft.
- **Lighting**  
Utilizes a medium base screw in type lamp (lamp not included). Accepts up to a 15W LED, 26W CFL or 100W Incandescent type A19 lamp.



Acceptable for use over tub or shower when installed in a GFCI protected branch circuit.

- **Unit Mounting**  
Rated Type IC for ceilings insulated to R-40. Designed to mount in ceilings with at least 6" of clearance. The unit will mount using the supplied mounting bars with a rough in opening of 7 3/8" x 7 5/8". The housing will mount through drywall thickness up to 3/4".
- **Single Pack Shipping Info**  
Box Dim: 11 1/2" x 13 1/4" x 9 1/2"  
Shipping Weight: 6 lbs.

<b>EXPANDED PERFORMANCE</b>											
	<i>Static Pressure (inches of w.g.)</i>							<i>Sones @ .1 SP</i>	<i>Fan Speed RPM</i>	<i>Maximum Fan Watts</i>	<i>Amps</i>
	0	0.05	0.1	0.125	0.15	0.2	0.25				
<b>Air Flow - CFM</b>	55	53	50	49	47	44	39	4.0	2125	48	1.4

<b>PROJECT</b>					<b>ARCHITECT</b>				
<b>LOCATION</b>					<b>ENGINEER</b>				
<b>CONTRACTOR</b>					<b>SUBMITTED BY</b>				<b>DATE</b>
FAN NUMBER	MODEL NUMBER	CFM	IN W.G.	RPM	WATTS	AMPS	SONES	QTY	OPTIONAL EQUIPMENT & REMARKS



**U.S.:** 820 Lincoln Avenue  
West Chester, Pennsylvania 19380-4466  
Tel: (610) 692-7400 • 877-304-3785  
Fax: (610) 696-8048

**Canada:**  
Brampton, Ontario  
Tel: 905-456-2033  
Fax: (905) 456-1015