

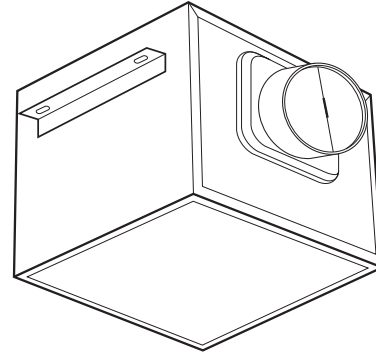

SPECIFICATIONS
AKZA200D
 INLINE FAN

HVI 2100 CERTIFIED
200 CFM @ 0.20" SP.
80 CFM @ 0.20" SP.



- Blower Wheel**
 Balanced polymeric dual inlet blower wheel secured in place using a hex nut.
- Motor**
 Enclosed 4 pole high efficiency, permanently split capacitor motor (PSC); life time lubrication, suitable for continuous operation. Motor bearings - sleeve. Rated 115/120 volts, 60 Hz.
- Fan Housing**
 23 gauge galvanized steel housing with 1" thermal & acoustical insulation and a removable bottom access panel for servicing. Overall dimensions: 12¹¹/₁₆" W x 13¹/₁₆" D x 12⁹/₁₆" H.
- Duct Collar**
 6" round, zinc plated metal collar adapter. Gasketed, spring loaded aluminum backdraft damper.

Model IA613R optional 6" round, zinc plated metal inlet collar adapter available separately.
- Electrical Connections**
 0.5" electrical knockouts provided. Easy wiring access via either internal or external wiring compartment cover.
- Single Pack Shipping Info**
 Shipping Weight: 17 lbs.

- Unit Mounting**
 2 supplied housing mounting angles. The housing mounting angles can be adapted for inline or top discharge mounting (hardware not provided).

Mounting Options

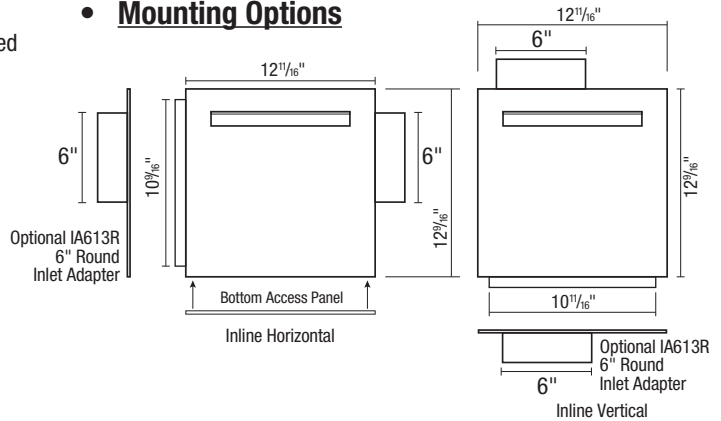

EXPANDED PERFORMANCE

	Static Pressure (inches of w.g.)							Fan Speed RPM	Maximum Fan Watts	Amps
	0	0.1	0.2	0.3	0.4	0.5	0.6			
Air Flow - CFM (High Speed)	216	209	200	187	167	135	93	1260	60.0	0.5
Air Flow - CFM (Low Speed)	100	90	80	69	55	36	-	1019	26.0	0.5

PROJECT					ARCHITECT				
LOCATION					ENGINEER				
CONTRACTOR					SUBMITTED BY			DATE	
FAN NUMBER	MODEL NUMBER	CFM	IN W.G.	RPM	WATTS	AMPS	SONES	QTY	OPTIONAL EQUIPMENT & REMARKS



Air King: 820 Lincoln Avenue
 West Chester, Pennsylvania 19380-4466
 Tel: (610) 692-7400 • 877-304-3785
 Fax: (610) 696-8048

Canada:
 Brampton, Ontario
 Tel: 905-456-2033
 Fax: (905) 456-1015