

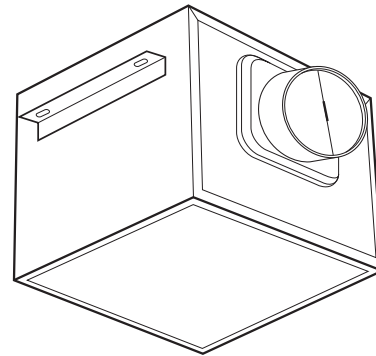

SPECIFICATIONS  
**AKZA150**  
 INLINE FAN

**HVI** 2100  
 CERTIFIED **120 CFM @ 0.20" SP.**

- **Blower Wheel**  
Balanced polymeric dual inlet blower wheel secured in place using a hex nut.
- **Motor**  
Enclosed 4 pole high efficiency, permanently split capacitor motor (PSC); life time lubrication, suitable for continuous operation. Motor bearings - sleeve. Rated 115/120 volts, 60 Hz.
- **Fan Housing**  
23 gauge galvanized steel housing with 1" thermal & acoustical insulation and a removable bottom access panel for servicing. Overall dimensions: 12<sup>11</sup>/<sub>16</sub>" W x 13<sup>1</sup>/<sub>16</sub>" D x 12<sup>9</sup>/<sub>16</sub>" H.
- **Duct Collar**  
6" round, zinc plated metal collar adapter. Gasketed, spring loaded aluminum backdraft damper.
- **Electrical Connections**  
0.5" electrical knockouts provided. Easy wiring access via either internal or external wiring compartment cover.
- **Single Pack Shipping Info**  
Shipping Weight: 17 lbs.



- **Unit Mounting**  
2 supplied housing mounting angles. The housing mounting angles can be adapted for inline or top discharge mounting (hardware not provided).

• **Mounting Options**

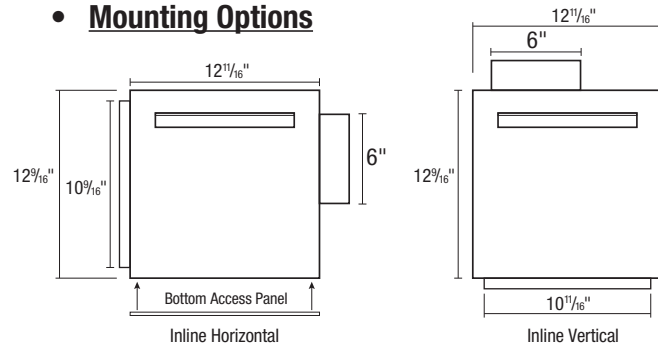

<b>EXPANDED PERFORMANCE</b>										
	<i>Static Pressure (inches of w.g.)</i>							<i>Fan Speed RPM</i>	<i>Maximum Fan Watts</i>	<i>Amps</i>
	0	0.1	0.125	0.2	0.25	0.375	0.5			
<b>Air Flow - CFM</b>	167	150	145	120	117	82	-	839	34.4	0.3

<b>PROJECT</b>					<b>ARCHITECT</b>				
<b>LOCATION</b>					<b>ENGINEER</b>				
<b>CONTRACTOR</b>					<b>SUBMITTED BY</b>			<b>DATE</b>	
FAN NUMBER	MODEL NUMBER	CFM	IN W.G.	RPM	WATTS	AMPS	SONES	QTY	OPTIONAL EQUIPMENT & REMARKS



**Air King:** 820 Lincoln Avenue  
 West Chester, Pennsylvania 19380-4466  
 Tel: (610) 692-7400 • 877-304-3785  
 Fax: (610) 696-8048

**Canada:**  
 Brampton, Ontario  
 Tel: 905-456-2033  
 Fax: (905) 456-1015