

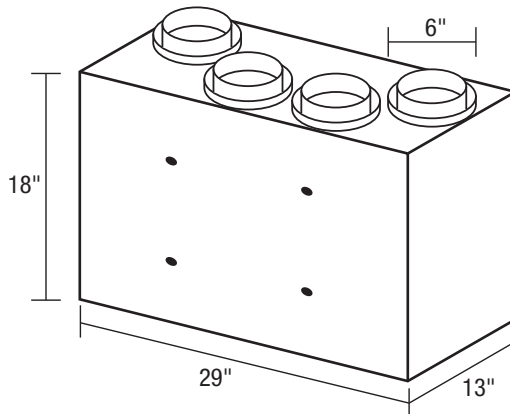

SPECIFICATIONS
AKHV160
HEAT RECOVERY VENTILATOR



- **Blower**
Two backward curve impellers using variable 2 speed PSC motors and permanently sealed bearings. Low speed is 40% of high speed.
- **Electrical**
120V 60 Hz., 1.0 amps.
- **Housing**
Insulated, white enamel finished aluminum.
Overall dimensions: 18"H x 13"D x 29"W.
- **Duct Collars**
6" round collar adapters.
- **Core**
Polypropylene cross-flow heat exchange core.
- **Defrost**
When outdoor temperature falls to -5° C (23° F) and colder, an automatic, timed defrost cycle is initiated. The exhaust air and the fresh air fans operate at reduced speed. An internal damper will shut off the cold exhaust port, directing return air through the core for defrosting. Normal operation resumes for a fixed duration, then the processor will read outdoor temperature and initiate defrost as necessary.
- **Unit Mounting**
Adjustable strap mounting system.
- **Test Port**
Differential pressure measuring ports on all unit doors.
- **Air Filter**
Cleanable, polyester air filters included. MERV 13 filters available separately.
- **Single Pack Shipping Info**
Shipping Weight: 30.0 lbs.
UPC: 0-8316294394-1

ADDITIONAL FEATURES

- Furnace interlock options: commands furnace blower when HRV is on or only on high speed.
- Intelligent Defrost: duration and interval adjust to outdoor conditions below -5° C (23° F).
- In defrost and recirculation modes, this unit will not induce indoor negative pressure nor recycle exhaust air; rather, it will redistribute ambient room air.
- Balancing: differential pressure ports on doors allow air measurements without flow grid in ductwork. Independent speed adjustment of either supply or exhaust motor in BOTH high and low speed.
- 24 V circuit protection with self resetting fuse.
- Drain, hanger kit featuring buckle-fitted adjustable poly straps, polyester air filters included.

| VENTILATION PERFORMANCE | | | |
|---------------------------------|---------------------------------|------------------|-------------------|
| Ext. Static Pressure In Wg (Pa) | Net Supply Airflow In CFM (L/s) | Gross Air Flow | |
| | | Supply CFM (L/s) | Exhaust CFM (L/s) |
| 0.1 (25) | 176 (83) | 176 (83) | 216 (102) |
| 0.2 (50) | 161 (76) | 163 (77) | 199 (94) |
| 0.3 (75) | 148 (70) | 148 (70) | 180 (85) |
| 0.4 (100) | 136 (64) | 136 (64) | 163 (77) |
| 0.5 (125) | 123 (58) | 123 (58) | 146 (69) |
| 0.6 (150) | 108 (51) | 108 (51) | 129 (61) |
| 0.7 (175) | 93 (44) | 93 (44) | 112 (53) |
| 0.8 (200) | 76 (36) | 76 (36) | 95 (45) |
| 0.9 (225) | 57 (27) | 57 (27) | 78 (37) |
| 1.0 (250) | 38 (18) | 38 (18) | 64 (30) |

| ENERGY PERFORMANCE | | | | | | |
|--------------------|----------------------|-----------------------|---------------|-----|------|----------------------------------|
| Temp Mode | Supply Temp. °F (°C) | Net Airflow CFM (L/s) | Power (Watts) | SRE | ASRE | Latent Recovery/Moister Transfer |
| Heating | +32 (0) | 66 (31) | 54 | 68% | 74% | 0.04 |
| Heating | +32 (0) | 91 (43) | 64 | 64% | 69% | 0.05 |
| Heating | +32 (0) | 117 (55) | 86 | 61% | 66% | 0.03 |

| | | | | | | | | | | |
|-------------------|---------------------|------------|----------------|------------|--------------|-------------|---------------------|------------|---|-------------|
| PROJECT | | | | | | | ARCHITECT | | | |
| LOCATION | | | | | | | ENGINEER | | | |
| CONTRACTOR | | | | | | | SUBMITTED BY | | | DATE |
| FAN NUMBER | MODEL NUMBER | CFM | IN W.G. | RPM | WATTS | AMPS | SONES | QTY | OPTIONAL EQUIPMENT & REMARKS | |
| | | | | | | | | | | |



U.S.: 820 Lincoln Avenue
 West Chester, Pennsylvania 19380-4466
 Tel: (610) 692-7400 • 877-304-3785
 Fax: (610) 696-8048