

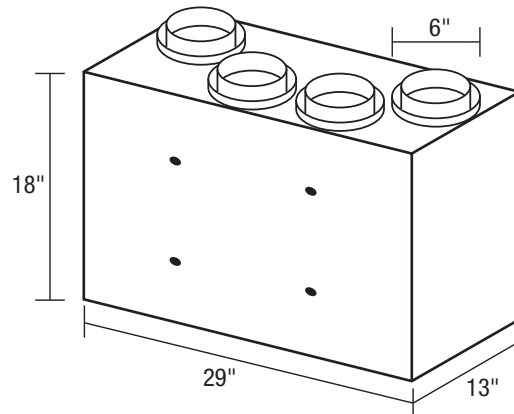

SPECIFICATIONS
AKEV160
ENERGY RECOVERY VENTILATOR



- **Blower**
Two backward curve impellers using variable 2 speed PSC motors and permanently sealed bearings. Low speed is 40% of high speed.
- **Electrical**
120V 60 Hz., 1.0 amps.
- **Housing**
Insulated, white enamel finished aluminum.
Overall dimensions: 18"H x 13"D x 29"W.
- **Duct Collars**
6" round collar adapters.
- **Core**
Enthalpy cross-flow heat exchange core.
- **Defrost**
When outdoor temperature falls to -5°C (23°F) an automatic timed defrost cycle is initiated. The exhaust air motor will go to high speed and the fresh air motor will turn off. Ambient air will circulate through the core for defrosting. Normal operation resumes for a fixed duration, then the processor will read outdoor temperature and initiate defrost as necessary. Defrost varies with outdoor temperature.
- **Unit Mounting**
Adjustable strap mounting system.
- **Test Port**
Differential pressure measuring ports on all unit doors.
- **Air Filter**
Cleanable, polyester air filters included. MERV 13 filters available separately.
- **Single Pack Shipping Info**
Shipping Weight: 30.0 lbs.
UPC: 0-8316294393-4

ADDITIONAL FEATURES

- Furnace interlock options: commands furnace blower when ERV is on or only on high speed.
- Intelligent Defrost: duration and interval adjust to outdoor conditions below -5° C (23° F).
- In defrost and recirculation modes, this unit will not induce indoor negative pressure nor recycle exhaust air; rather, it will redistribute ambient room air.
- Balancing: differential pressure ports on doors allow air measurements without flow grid in ductwork. Independent speed adjustment of either supply or exhaust motor in BOTH high and low speed.
- 24 V circuit protection with self resetting fuse.
- Hanger kit featuring buckle-fitted adjustable poly straps, polyester air filters included.

VENTILATION PERFORMANCE			
Ext. Static Pressure In Wg (Pa)	Net Supply Airflow In CFM (L/s)	Gross Air Flow	
		Supply CFM (L/s)	Exhaust CFM (L/s)
0.1 (25)	153 (72)	159 (75)	153 (72)
0.2 (50)	140 (66)	146 (69)	144 (68)
0.3 (75)	127 (60)	131 (62)	131 (62)
0.4 (100)	112 (53)	117 (55)	121 (57)
0.5 (125)	97 (46)	102 (48)	108 (51)
0.6 (150)	81 (38)	85 (40)	97 (46)
0.7 (175)	61 (29)	64 (30)	89 (42)

ENERGY PERFORMANCE						
Temp Mode	Supply Temp. °F (°C)	Net Airflow (L/s)	Power (Watts)	SRE	ASRE	Latent Recovery/ Moisture Transfer
Heating	+32 (0)	30	60	74%	80%	0.74
Heating	+32 (0)	54	100	68%	74%	0.70
Cooling	95 (35)	31	60			0.45

PROJECT							ARCHITECT				
LOCATION							ENGINEER				
CONTRACTOR							SUBMITTED BY			DATE	
FAN NUMBER	MODEL NUMBER	CFM	IN W.G.	RPM	WATTS	AMPS	SONES	QTY	OPTIONAL EQUIPMENT & REMARKS		



U.S.: 820 Lincoln Avenue
 West Chester, Pennsylvania 19380-4466
 Tel: (610) 692-7400 • 877-304-3785
 Fax: (610) 696-8048