



SPECIFICATIONS

9155

WINDOW FAN

16" Window Fan

- **Motor**
3-speed, 1/6 HP, 120V, 1 phase, ball bearing, permanently lubricated, permanent split capacitor
- **Controls**
Front mounted rotary switch
- **Power Cord**
White, 7', 3-conductor, SPT-2-R type
- **Construction**
High impact styrene housing, ABS plastic blade, and metal front grill
- **Compliance**
ETL, OSHA
- **Window Size Requirements**
26.5" to 34.5" x 22"H
- **Shipping Information**
UPC: 0-46013-38010-4
Shipping Weight: 15 lbs.

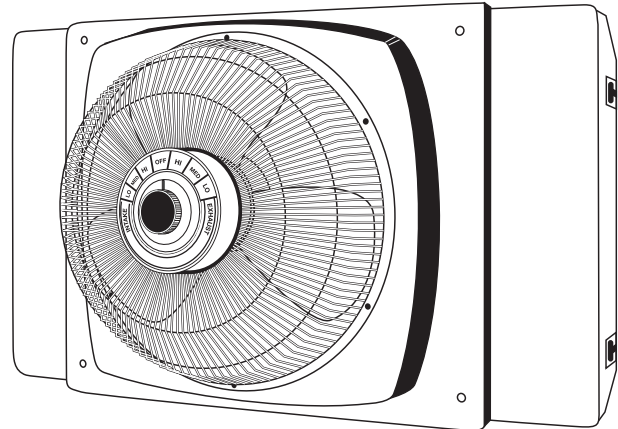

MODEL	CFM			AMPS			BLADE SIZE	MOTOR SIZE	SHIP WEIGHT
	HIGH	MED	LOW	HIGH	MED	LOW			
9155	2470	1700	1360	0.8	0.6	0.5	16"	1/6 HP	15 lbs



U.S.: 820 Lincoln Drive
West Chester, Pennsylvania 19380-4466
Tel: (610) 692-7400 • 877-304-3785
Fax: (610) 696-8048