

# AGA Dual Control 3-Oven Cast Iron Range – Electric



**Model # ADC3E**



- Cast iron radiant heat cooking throughout each oven and both hotplates providing 10 Cooking Methods in one range
- Three Large Capacity Multi-Function Cast Iron Ovens – Roasting oven (approx. 425°F-475°F), Baking oven (approx. 325°F-375°F) and Slow Cook oven (approx. 212°F-245°F)
- Two 14 ½" diameter Cast Iron Hotplates – Boiling hotplate (626°F) and Simmering hotplate (392°F) can accommodate extra-large and multiple pans or may be used as a griddle cooking surface
- The ovens are heated by a single Heat Source giving gradual radiant heat to bring solid cast iron to temperature
- Ovens will heat to full temperature in 8 hours from cold or 4 hours from Slumber and operate simultaneously; new bullet Hotplates take under 11 minutes to reach full temperature
- Hotplates operate independent from the ovens and separate from each other

| ORDERING DETAILS | MODEL #   |
|------------------|-----------|
| Black            | ADC3E-BLK |
| Pewter           | ADC3E-PWT |
| Cream            | ADC3E-CRM |
| White            | ADC3E-WHT |
| Dark Blue        | ADC3E-DBL |
| Pearl Ashes      | ADC3E-PAS |
| Aubergine        | ADC3E-AUB |
| Duck Egg Blue    | ADC3E-DEB |
| Pistachio        | ADC3E-PIS |

**Cast iron range is coated in hygienic, easy-to-clean vitreous enamel**



Black



Pewter



Cream



White



Pistachio



Dark Blue



Pearl Ashes



Aubergine



Duck Egg Blue

# AGA Dual Control 3-Oven Cast Iron Range – Electric

# AGA

**Model # ADC3E**

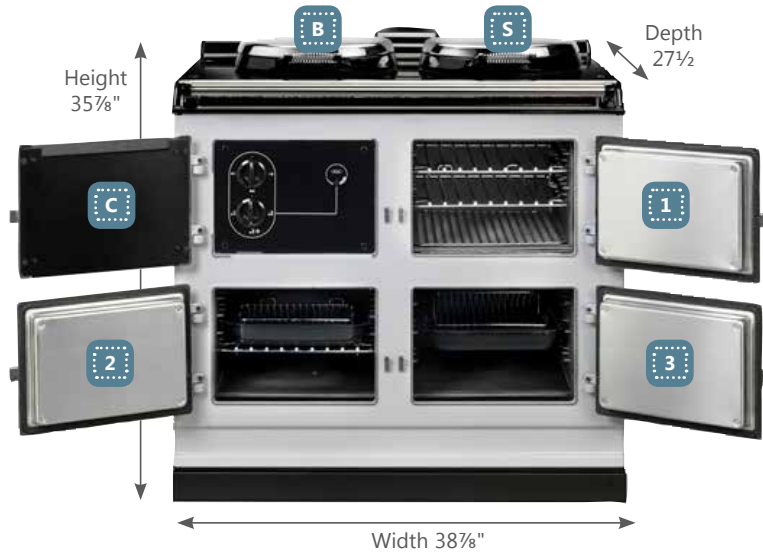

| Technical Specifications |   |
|--------------------------|---|
| Overall Dimensions       | 35 7/8" H x 38 7/8" W x 27 1/2" D       |
| 1. Roasting Oven         | 9 5/8" H x 13 5/8" W x 18 3/4" D        |
| 2. Baking Oven           | 9 5/8" H x 13 5/8" W x 18 3/4" D        |
| 3. Slow Cook Oven        | 9 5/8" H x 13 5/8" W x 18 3/4" D        |
| B. Boiling Plate         | 14 1/2" Dia                             |
| S. Simmering Plate       | 14 1/2" Dia                             |
| C. Control Panel         | 9 5/8" H x 13 5/8" W                    |
| Weight                   | 816 lbs                                 |
| Shipping Weight          | 1135 lbs                                |
| Electrical Requirements  | 240v, 40amp, 60Hz                       |
| Fuel/Power               | Electric                                |
| Vent Options             | In room venting flue                    |
| Warranty                 | 5 Year Limited Warranty<br>1 Year Labor |
| Shipping Instruction     | Ships fully assembled                   |

## Complimentary Cookware Included

- (1) 13" x 18" Large Enamelled Roasting Pan with Broiling Rack
- (1) 12 1/2" x 13 1/2" Half Size Enamelled Roasting Pan with Broiling Rack
- (3) 17" x 13 1/2" Oven Grid Shelves
- (1) Cold Plain Shelf
- (1) Hotplate Toaster
- (1) Wire Brush

## CAST IRON EVIDENCE



Acclaimed as one of the most perfect mediums for great cooking because it retains heat well, has even heat distribution and radiates a gentle heat aiding food in flavor retention and succulence.

Cast iron cooking means ease of cleaning because oven splashes and spills are carbonized and simply require wiping out. An AGA also means fewer intrusive cooking smells.

The cast iron AGA is made from 70% recycled material and is itself 95% recyclable. Inside every new AGA is a bit of an old one.

## INSULATED COVERS



The distinctive hallmark of the AGA, the highly polished stainless steel insulated covers are brought down over the hotplates to help contain the heat when on and protect the hotplate when off.

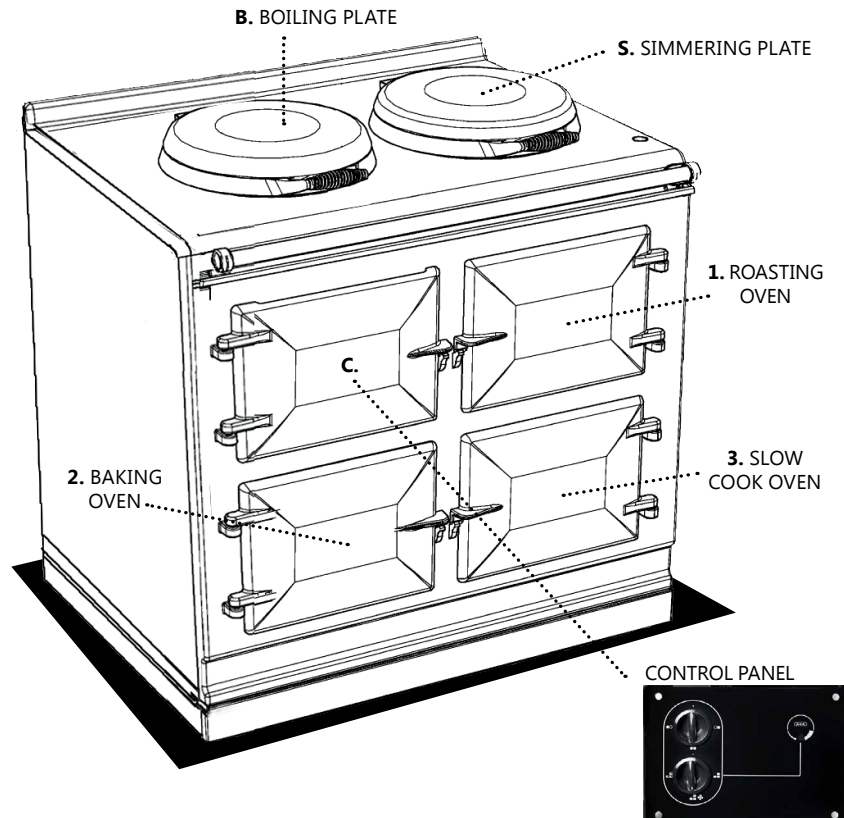

# AGA Dual Control 3-Oven Cast Iron Range – Electric



Model # ADC3E

## Installation

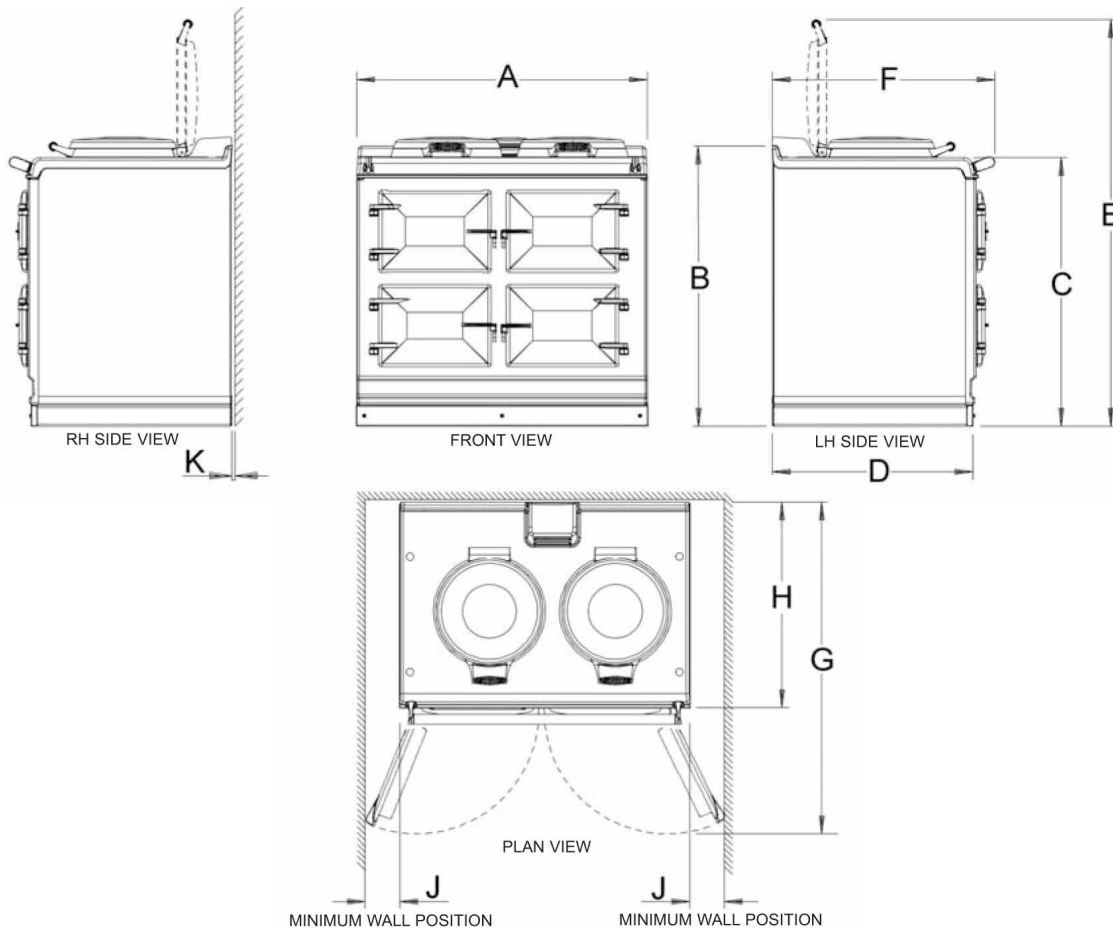

### Range Dimensions

When surveying for a range installation the actual clearance required for the 'body' of the appliance should be increased by  $\frac{3}{8}$ " (10mm) beyond the figures quoted above. This allows safe margin to take into account the natural dimensional variations found in major castings. In particular the width across the appliance recess could be critical.

|     | A                | B                | C                | D                | E                | F                | G                | H                | J               | K   | L   |
|-----|------------------|------------------|------------------|------------------|------------------|------------------|------------------|------------------|-----------------|-----|-----|
| mm  | 987              | 945              | 910              | 680              | 1385             | 760              | 1145             | 698              | 116             | 10  | 634 |
| ins | 38 $\frac{7}{8}$ | 37 $\frac{3}{8}$ | 35 $\frac{7}{8}$ | 26 $\frac{3}{4}$ | 54 $\frac{5}{8}$ | 29 $\frac{7}{8}$ | 45 $\frac{1}{8}$ | 27 $\frac{1}{2}$ | 4 $\frac{5}{8}$ | 3/8 | 25  |

### Range Base or Hearth

It is essential that the base or hearth on which the range stands should be level. The base of the built-in AGA plinth must be level and sit above finished floor height for service access.

### Plinth

The front plinth cover is removable and must not be obstructed by flooring or tiles. If necessary the range must be raised by the thickness of the tiles to ensure the plinth can be removed.

### Minimum Clearance to Combustibles

A gap of at least  $\frac{1}{2}$ " must be observed between the rear of the top plate, and the wall behind the appliance. If the rear wall is of combustible material there must be a gap of 1" (25mm).

### Side Clearances

A  $\frac{1}{8}$ " (3mm) gap is required each side between the range top plate and adjoining work surfaces that may be fitted, this is to allow for the safe removal of the top plate should this be required at a later date.

Where ranges are fitted against side walls a  $4 \frac{9}{16}$ " (116mm) side clearance is required on the right and left hand side for oven doors access.

If the AGA is to be installed in a brick recess, then the minimum clearance should be increased by at least  $\frac{3}{8}$ " (10mm), to allow for the walls not being square.

In addition a minimum clearance of  $39 \frac{1}{2}$ " (1000mm) must be available at the front of the range to enable it to be serviced.

### Range Hoods

It is recommended this AGA is fitted with a range hood. The AGA venting system is located on top of the AGA between the two hotplates, and is designed for venting the moisture from the ovens. The range hood should be positioned not less than the minimum height as recommended by the manufacturer, from the top of the AGA.