



STAINLESS STEEL GOWNING BENCHES



SOLID TOP

Item #: _____ Qty #: _____
 Model #: _____
 Project #: _____

FEATURES:

Top is furnished with 1 5/8" sanitary rolled rim edges on front and back.
 Sides are 1 5/8" and turned down square.
 Rainbow legs are formed for maximum stability and can be adapted for floor mounting. Cross stretcher bolted to rainbow legs. Assembly required.

CONSTRUCTION:

All TIG Welded.
 Welded areas blended to match adjacent surfaces and polished to a #4 finish. Die formed rolled rim edges.
 Stud welded hat section reinforces and maintains a level seating area.

MATERIAL:

TOP: 16 gauge stainless steel type "304" series.

LEGS: 1 5/8" diameter tubular stainless steel and 1" adjustable plastic bullet feet.

Stainless steel gussets.

STRETCHER: 1 5/8" diameter tubular "304" series stainless steel.

Model #	O.A. Size Width x Length	Approx. Weight	Approx. Cu. Ft.
BKR-3	12" x 36"	36 lbs.	4
BKR-4	12" x 48"	42 lbs.	5
BKR-5	12" x 60"	53 lbs.	6
BKR-6	12" x 72"	62 lbs.	7
BKR-7	12" x 84"	67 lbs.	8
BKR-8	12" x 96"	77 lbs.	9

ACCESSORIES	MODEL #	Qty
Special Modification Size	BA-10	
S/S Flanged Feet	BA-11	
Electropolish	BA-13	
Welded Setup	BA-14	

FOR CLEANROOMS WITH CLASS A 100-100,000 RATING

DIMENSIONS and SPECIFICATIONS

TOL ± .500"

ALL DIMENSIONS ARE TYPICAL

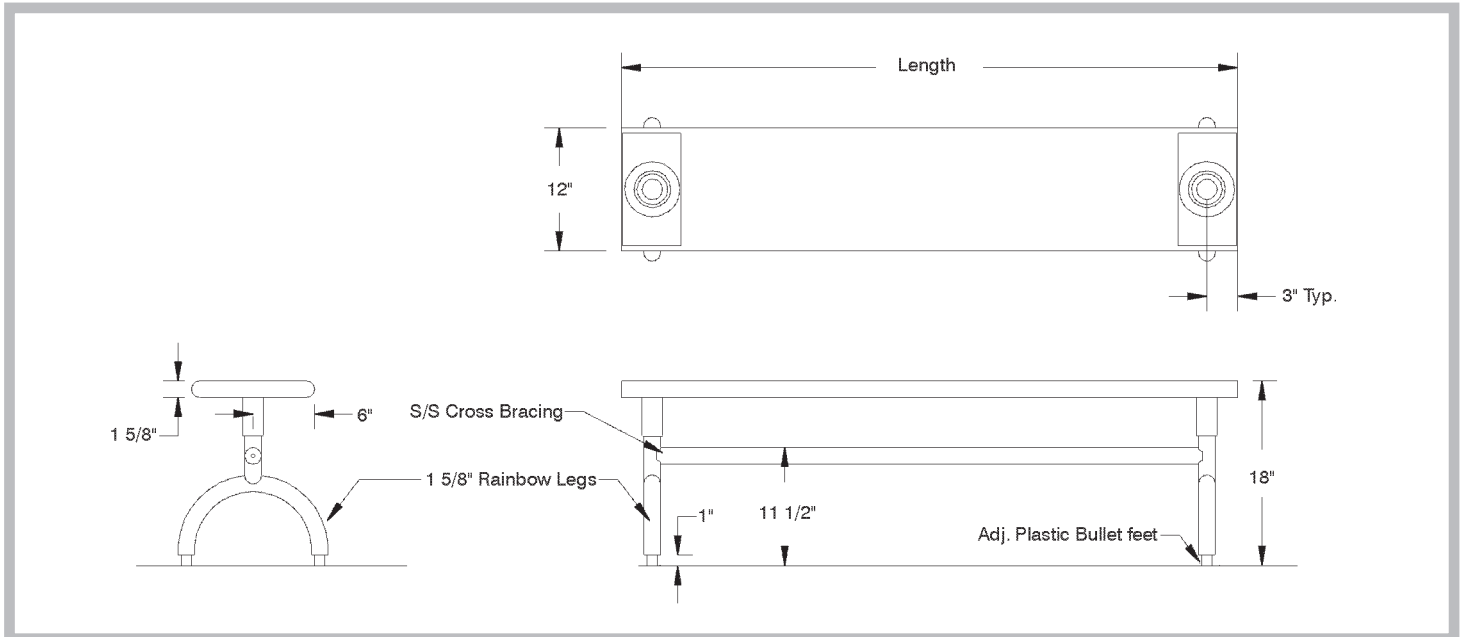

Customer Service Available To Assist You 1-800-645-3166 8:30 am - 7:00 pm E.S.T.

For Orders & Customer Service:

Email: customer@advancetabco.com or Fax: 631-242-6900

For Smart Fabrication™ Quotes:

Email: smartfab@advancetabco.com or Fax: 631-586-2933