

*****READ & SAVE THESE INSTRUCTIONS*****
MODEL 62067/68/69/70
INSTALLATION & OPERATION INSTRUCTIONS

1) TOOLS AND MATERIALS REQUIRED

- ❖ BLADE SCREW DRIVER
- ❖ STEP LADDER
- ❖ WIRE CUTTERS
- ❖ WIRING SUPPLIES AS REQUIRED BY ELECTRICAL CODE

Attention:

Before assembling your lighting fixture, please read the following instructions. If you feel you do not have sufficient electrical experience, refer to a do-it-yourself wiring handbook or have your fixture installed by a qualified licensed electrician.

(2) GENERAL

1. To ensure the success of the installation, be sure to read these instructions and review the diagrams thoroughly before beginning.
2. All electrical connections must be in accordance with local codes, ordinances, or the National Electrical Code. If you are unfamiliar with methods of installing electrical wiring, secure the services of a qualified licensed electrician.
3. These fixtures are intended for mounting to a standard 4" x 2 1/4" deep metal octagon outlet box. The box must be directly supported by the building structure.
4. Before commencing with the installation, **disconnect the power by turning off the circuit breaker** or by removing the fuse at the fuse box. Turning the power off using the light switch is not sufficient to prevent electrical shock.

NOTE:

The important safeguards and instructions appearing in this manual are not meant to cover all possible conditions and situations that may occur. It must be understood that common sense, caution and care, are factors that cannot be built into any product. These factors must be supplied by the person(s) caring for and operating the fixture.

(3) UNPACKING THE FIXTURE

On checking the contents of the box you will find;

1. Fixture assembly
2. 2/3/4/5 x Bulb Covers
3. 2/3/4/5 x G9 40w Lamps (Model Dependant)
4. Mounting Hardware Pack

(4) PREPARE THE FIXTURE

Refer to figure 1 for illustration of fixture parts and assembly.

1. If you are replacing an existing fixture, disconnect and remove the old fixture. Expose the supply wiring from the outlet box.
2. Lay the un-assembled fixture on a soft surface and carefully remove all the packing material.
3. Determine the best location for your fixture. Position the **(9) Back plate** as desired, mark screw holes with a pencil and then drill holes. Place the supplied **(1) Screw plugs** into the holes.
4. Mount the fixture back plate to the junction box by inserting the **(2) Mounting screws** into the screw holes found on the circumference of the hole in the middle of the back plate. Insert the two **(3) Screws** into the screw holes located on either end of the back plate. These screws will insure added support and secure the location of your fixture.
5. Connect the supply wires from the junction box to the fixture wires. The Black supply wire attaches to the Black fixture wire and the White supply wire attaches to the White fixture wire. Attach the ground (copper wire) from the fixture to the outlet box ground terminal or (the box ground wire). Secure these connections with supplied **(4) Wire nuts** and tape these connections with electrical tape.
6. Place the **(10) Front plate** over the **(9) Back plate**, making sure that you line up the screw holes. Secure the front plate with provided **(5) Knobs**.
7. Insert the **(6) G9 40w lamps** and install glass **(7) Bulb covers** over the lamps.
8. Slide **(8) glass diffuser** into the slot located on either side of the front plate.
9. Restore electricity and enjoy your new lighting fixture.

CAUTION:

- **Ensure that the Fitting is Cool and Switched off, Before Changing the Bulb.**
- **Do Not use Bulbs Exceeding Maximum Wattage, as Per Caution Label.**
- **Do Not Touch the Bulb while fixture is in operation.**

SEE FIGURE 1 ON REVERSE SIDE OF THIS PAPER

access
LIGHTING

MODEL 62067/68/69/70

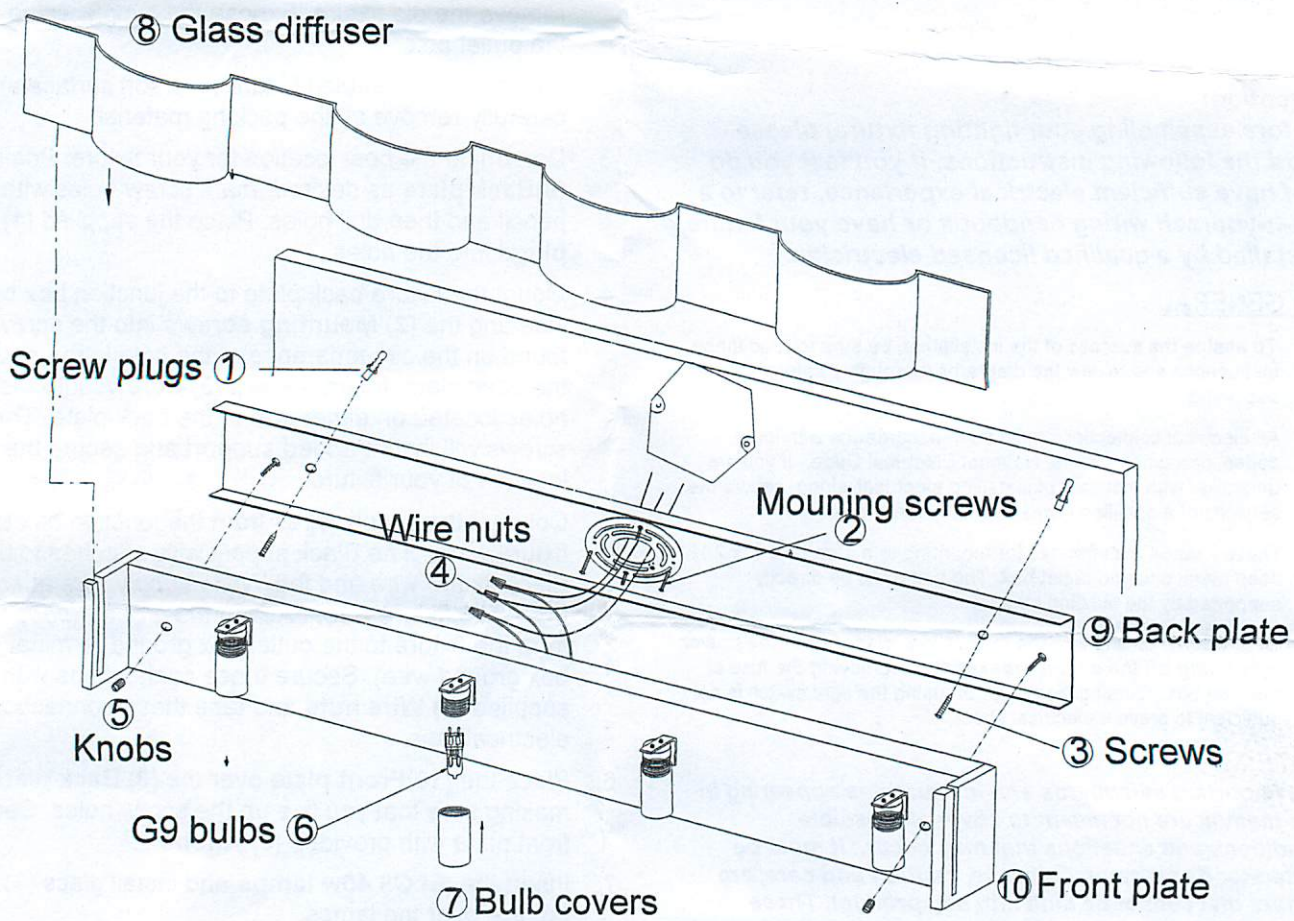

access
LIGHTING