

access

L I G H T I N G

INSTALLATION INSTRUCTIONS

IMPORTANT

Before assembling your access lighting fixture, please make sure that you carefully read through these instruction sheets. Consider having your fixture installed by a qualified licensed electrician.

NOTE: The important safeguards and instructions that appear in this manual are not meant to cover all possible conditions and situations that may occur. It must be understood that common sense, caution and care, are factors that can't be built into any product. These factors must be supplied by the person(s) caring for and operating the fixture.

GENERAL INFORMATION

All electrical connections must be in accordance with all ordinances, Local and National Electrical Codes. These fixtures are intended for mounting to a standard 4" x 2 1/2" metal octagon outlet box. The box must be directly supported by the building structure and U.L. Recognized.

STEP BY STEP INSTRUCTIONS

Before starting your installation disconnect the Power by turning off the Circuit Breaker or by removing the fuse at the fuse box. Just turning the light off at the light switch is not sufficient to prevent electrical shock.

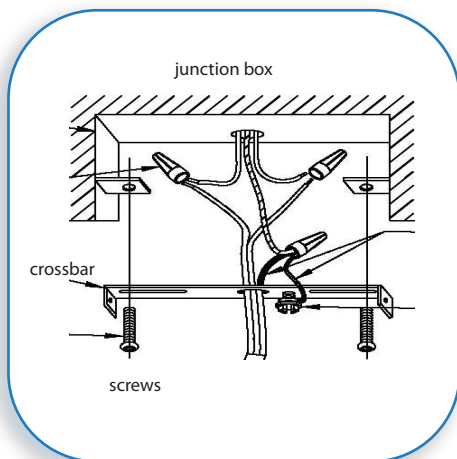

COLLECTION

Safari

APPLICATION

Pendant

MODEL NO.

23642/23640

WHAT WE PROVIDE

- Crossbar
- Mounting Hardware
- Glass Shade
- Fixture

WHAT YOU NEED

- Screwdriver
- Wire Cutters
- Wiring Supplies as Specified by Electrical Code
- 1 x 100w A-19(23640/2)
- 1 x 10w A-19 LED (23642LEDDL)

1

MOUNT CROSSBAR

If there is an existing fixture remove it. Expose the supply wire from the outlet box. Mount the universal crossbar to the junction box with the supplied screws.

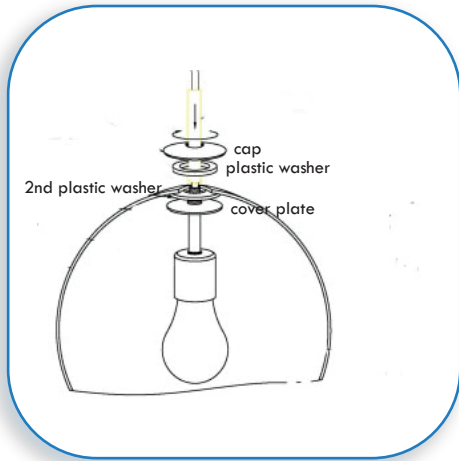

2

SECURING THE DIFFUSER

Remove the cap and plastic washer from the fixture.

Note: you need not remove the cover plate or plastic washer.

Feed the fixture wire through the diffuser, the plastic washer and the cap. Secure the cap to the fixture firmly.

Remember to handle the diffuser with care to avoid breakage.

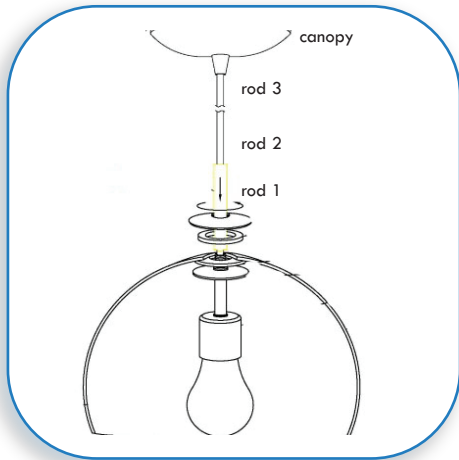

3

SECURE THE RODS

Prepare the fixture by placing rod 3 down, through the hole in the canopy. Feed both the fixture and ground wire up through the rods (1,2,3) to the canopy. Screw rod 1 into the nipple protruding from the fixture, now screw the remaining rods together.

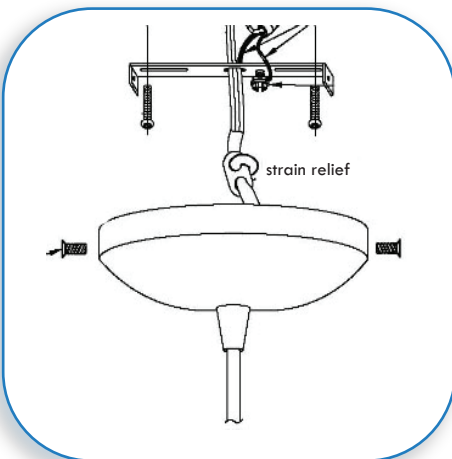

4

ADJUST LENGTH AND CONNECT WIRES

Pull the supply wires through the center hole in the crossbar. Determine the desired length of your fixture, remove the strain relief, cut the wire leaving at least 1" to make the necessary connections. Replace the strain relief. Connect the black supply wires to the black fixture wires, the white supply wires to the white fixture wires and the green wire (ground) from the fixture to the outlet box ground terminal, or to the green screw. Secure all wire connections with wire nuts and U.L. listed electrical tape.

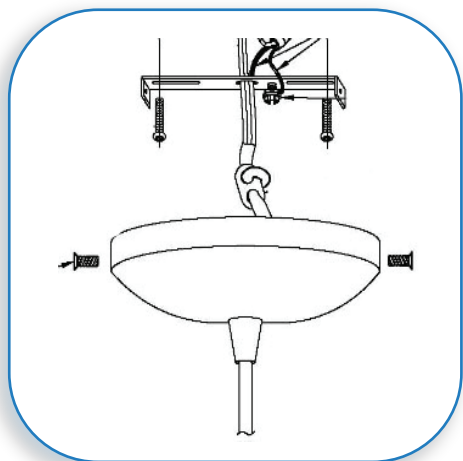

5

MOUNT CANOPY TO CROSSBAR

Cover the crossbar with the canopy. Align the holes in the side of the canopy with the holes in the over hang of the crossbar. Insert the supplied screws and tighten down to secure.



6

INSERT BULB

Insert your bulb into the socket.

DO NOT EXCEED THE WATTAGE AS PER CAUTION LABEL.



RESTORE THE ELECTRICITY AND CHECK THE OPERATION OF YOUR NEW ACCESS FIXTURE

CAUTION

Please ensure that the fitting is cool and switched off before replacing the bulb. DO NOT use bulbs that might exceed the maximum wattage, stated on caution label.